

REASSEMBLY

HINT:

- Thoroughly clean all parts to be assembled.
- Before installing the parts, apply new engine oil to all sliding and rotating surfaces.
- Replace all gaskets and oil seals with new ones.

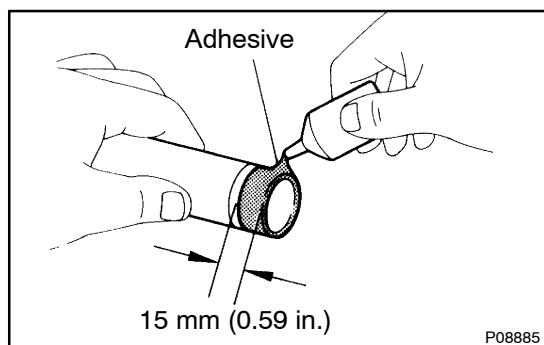

1. INSTALL SPARK PLUG TUBES

HINT:

When using a new cylinder head, spark plug tubes must be installed.

- (a) Apply adhesive to the end of the spark plug tube.

Adhesive:

Part No. 08833-00070, THREE BOND 1324 or equivalent

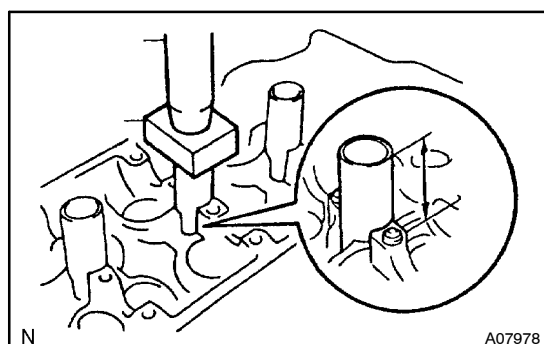

- (b) Using a wooden block and hammer, tap in a new spark tube until there is 43.0 – 44.0 mm (1.693 – 1.732 in.) protruding from the camshaft bearing cap installation surface of the cylinder head.

NOTICE:

Avoid tapping a new spark plug tube in too far by measuring the amount of the protrusion while tapping.

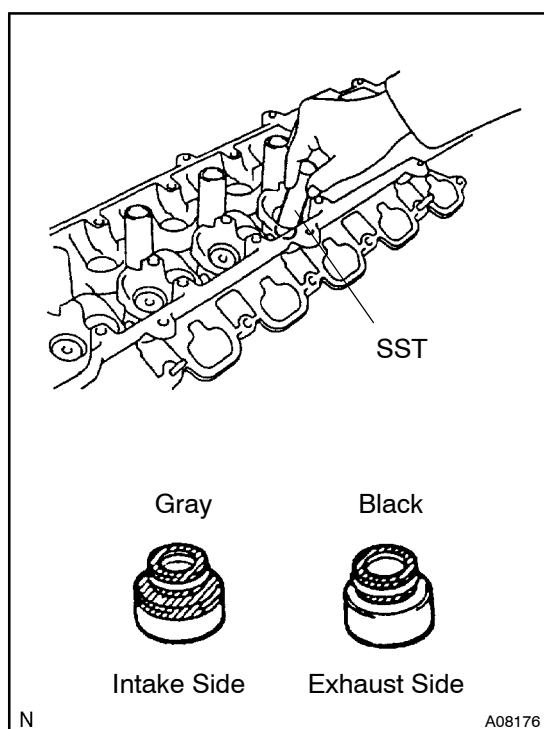

2. INSTALL VALVES

- (a) Using SST, push in a new oil seal.
SST 09201-41020
- (b) Install the valve, valve spring seat, valve spring and spring retainer.

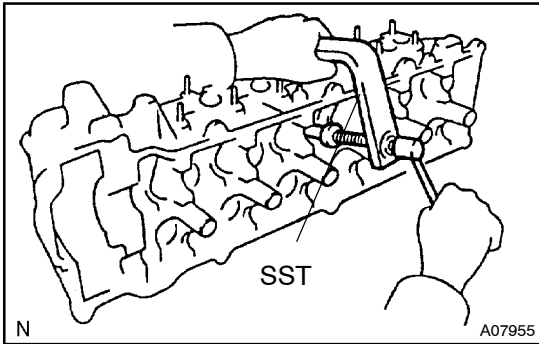

- (c) Using SST, compress the valve spring and place the 2 retainer locks around the valve stem.
SST 09202-70020 (09202-00010)
- (d) Using a plastic-faced hammer, with the valve stem (not in use) tip wound with vinyl tape, lightly tap the valve stem tip to assure proper fit.

NOTICE:

Be careful not to damage the valve stem tip.

3. INSTALL SHIMS AND VALVE LIFTERS

- (a) Install the shims and valve lifters.
- (b) Check that the valve lifter rotates smoothly by hand.