

BR5332

INSPECTION

1. INSPECT DISASSEMBLED PARTS

Inspect the disassembled parts for wear, rust or damage.

2. MEASURE BRAKE SHOE LINING THICKNESS

Using a ruler, measure the thickness of the shoe lining.

Standard thickness: 2.5 mm (0.098 in.)

Minimum thickness: 1.0 mm (0.039 in.)

If the lining thickness is at the minimum or less, or if there is severe, uneven wear, replace the brake shoe.

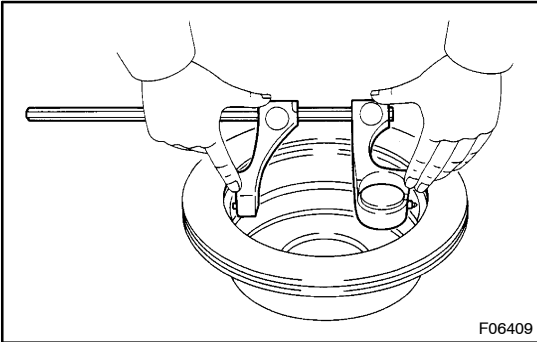

F06409

3. MEASURE DISC INSIDE DIAMETER

Using a brake drum gauge or equivalent, measure the inside diameter of the disc.

Standard inside diameter: 190 mm (7.48 in.)

Maximum inside diameter: 191 mm (7.52 in.)

Replace the disc if the inside diameter is at the maximum value or more. Replace the disc or grind it with a lathe if the disc is scored or worn unevenly.

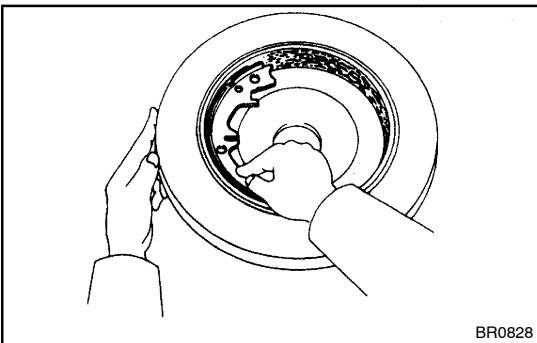

BR0828

4. INSPECT PARKING BRAKE LINING AND DISC FOR PROPER CONTACT

Apply chalk to the inside surface of the disc, then grind down the brake shoe lining to fit. If the contact between the disc and the brake shoe lining is improper, repair it using a brake shoe grinder or replace the brake shoe assembly.

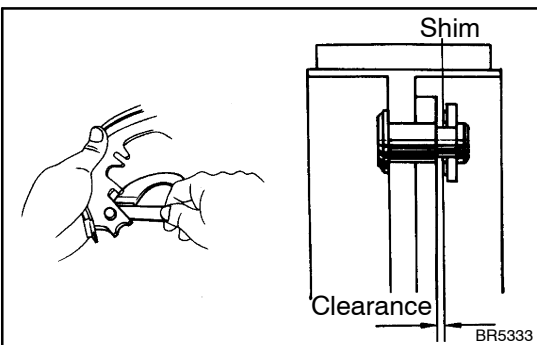

BR5333

5. MEASURE CLEARANCE BETWEEN PARKING BRAKE SHOE AND LEVER

Using a feeler gauge, measure the clearance.

Standard clearance: Less than 0.35 mm (0.0138 in.)

If the clearance is not within the specification, replace the shim with one of the correct size.

Thickness mm (in.)	Thickness mm (in.)
0.3 (0.012)	0.9 (0.035)
0.6 (0.024)	-

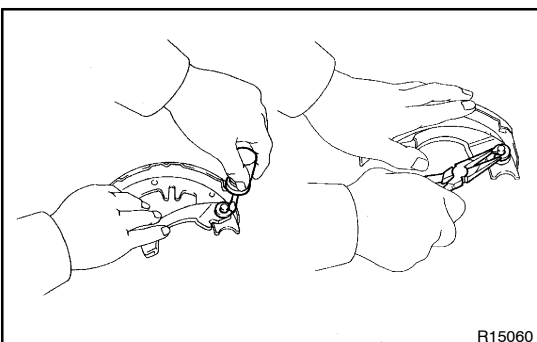

R15060

6. IF NECESSARY, REPLACE SHIM

- Using a screwdriver, remove the C-washer and shim.
- Install the correct size shim with a new C-washer.
- Remeasure the clearance.