

R12557

REPLACEMENT

1. REMOVE REAR WHEEL

2. INSPECT PAD LINING THICKNESS

Check the pad thickness through the caliper inspection hole and replace pads if they are not within the specification.

Minimum thickness: 1.0 mm (0.039 in.)

3. REMOVE CALIPER

(a) Hold the sliding pin and loosen the installation bolt.

(b) Remove the 2 installation bolts.

(c) Remove the caliper and suspend it securely.

HINT:

Do not disconnect the flexible hose from the caliper.

4. REMOVE PADS

(a) Remove the 2 anti-squeal springs.

(b) Remove the 2 pads.

(c) Remove the 4 anti-squeal shims.

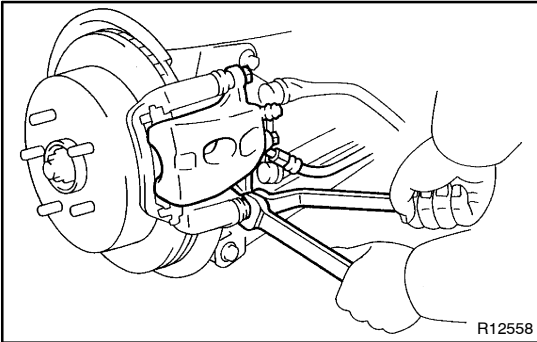

R12558

(d) Right wheel:

Remove the clip, and disconnect the pad wear indicator from the inner pad.

(e) Remove the 4 pad support plates.

NOTICE:

The anti-squeal springs and support plates can be used again provided that they have sufficient rebound, no deformation, cracks or wear, and have had all rust, dirt and foreign particles cleaned off.

5. RIGHT WHEEL:

CHECK PAD WEAR INDICATOR (See page BR-41)

6. CHECK DISC THICKNESS AND RUNOUT (See page BR-41)

7. INSTALL 4 PAD SUPPORT PLATES

8. INSTALL NEW PADS

NOTICE:

When replacing worn pads, the anti-squeal shims must be replaced together with the pads.

(a) Apply disc brake grease to both sides of the inner anti-squeal shims (See page BR-38).

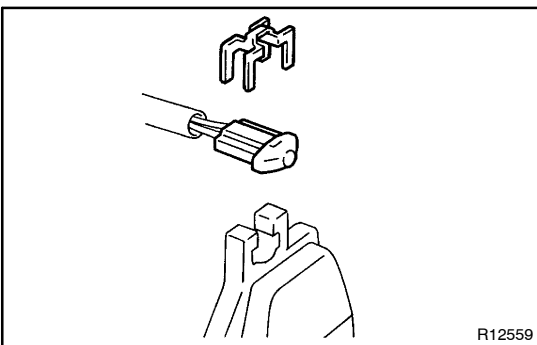

R12559

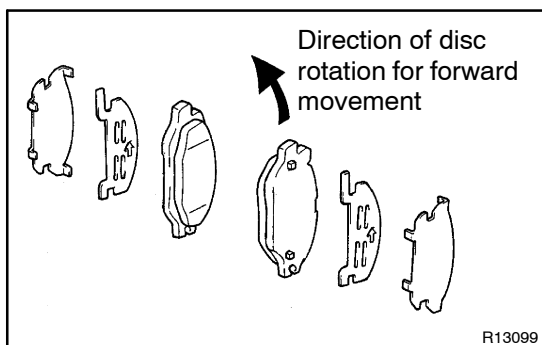

- (b) Install the 2 anti-squeal shims to each pad.

HINT:

Make sure the inner anti-squeal shims are facing the front (rotation direction) as shown in the illustration.

- (c) Right wheel:

Connect the pad wear indicator to the inner pad, and install a new clip. Then install the inner pad with the pad wear indicator facing downward.

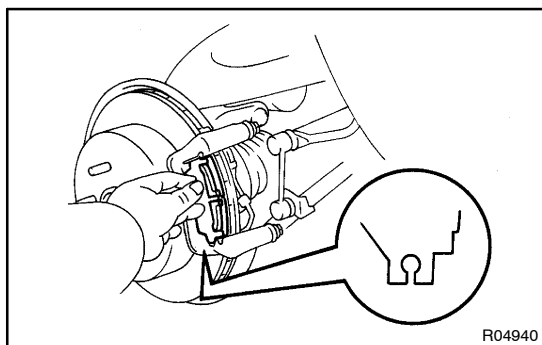

- (d) Install the other pads, as shown in the illustration.

NOTICE:

There should be no oil or grease adhering to the friction surfaces of the pads or disc.

- (e) Install the 2 anti-squeal springs.

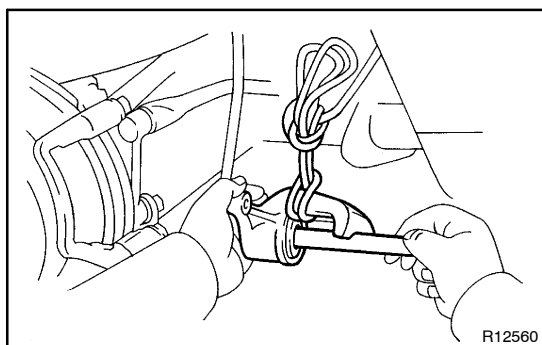

9. INSTALL CALIPER

- (a) Draw out a small amount of brake fluid from the reservoir.
 (b) Press in the piston with a hammer handle or similar implement.

HINT:

If the piston is difficult to push in, loosen the bleeder plug and push in the piston while letting some brake fluid escape.

- (c) Temporarily install the caliper on the torque plate with the 2 installation bolts.
 (d) Hold the sliding pin and torque the 2 installation bolts.
Torque: 34 N·m (350 kgf·cm, 25 ft·lbf)

10. INSTALL REAR WHEEL

Torque: 103 N·m (1,050 kgf·cm, 76 ft·lbf)

11. DEPRESS BRAKE PEDAL SEVERAL TIMES

12. CHECK THAT FLUID LEVEL IS AT MAX LINE