

DTC	16	Air Duct Sensor Circuit (Passenger Side)
------------	-----------	---

CIRCUIT DESCRIPTION

This sensor detects the temperature inside and sends the appropriate signals to the A/C control assembly.

DTC No.	Detection Item	Trouble Area
16	Open or short in duct sensor circuit.	<ul style="list-style-type: none"> • Duct sensor. • Harness or connector between duct sensor and A/C control assembly. • A/C control assembly.

WIRING DIAGRAM

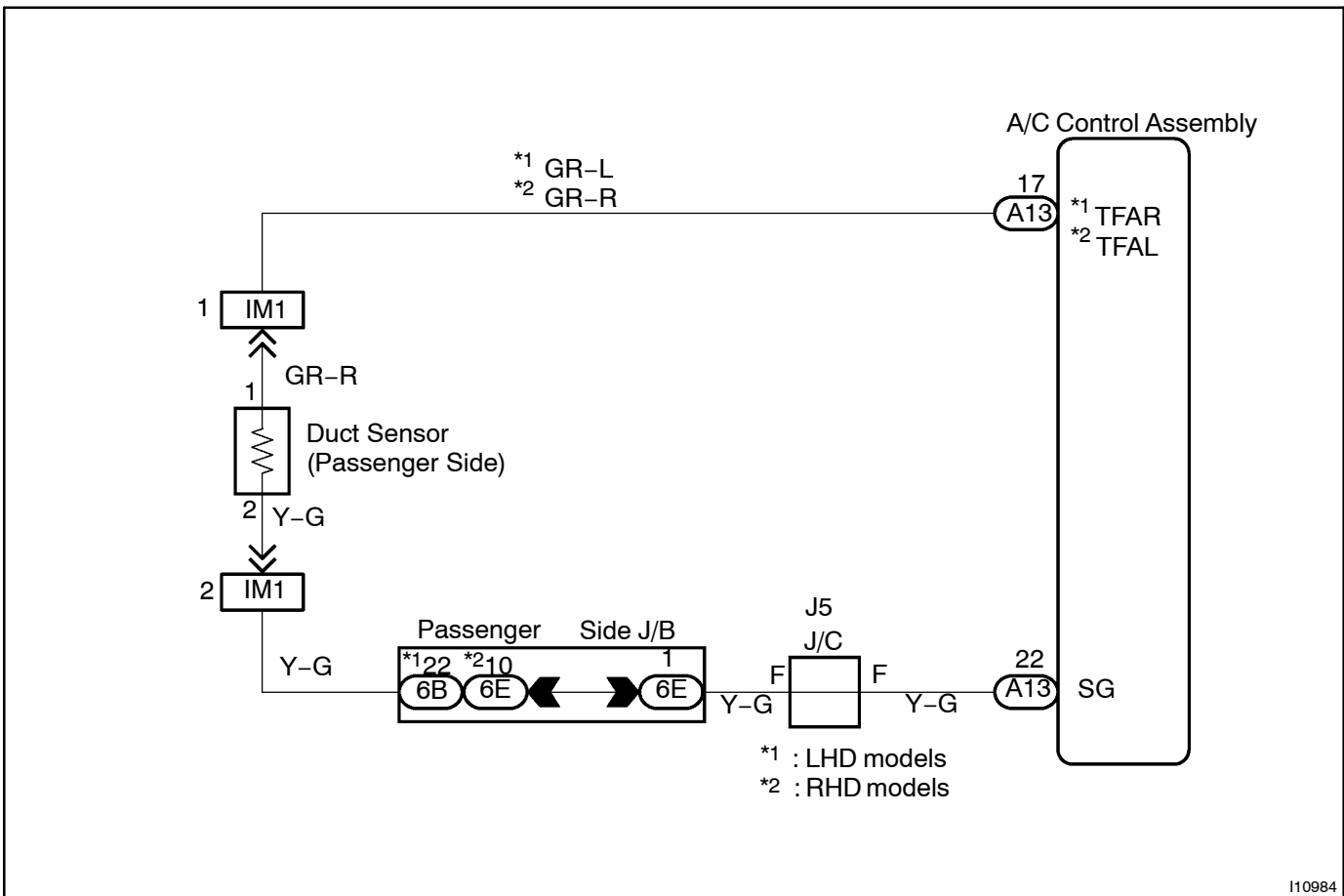

INSPECTION PROCEDURE

- 1 Check voltage between terminals TFAR (RHD: TFAL) and SG of A/C control assembly connector.

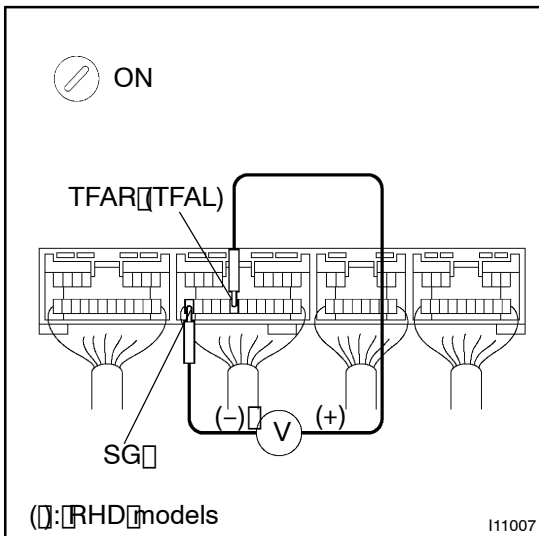
**PREPARATION:**

Remove A/C control assembly with connectors still connected.

CHECK:

- Turn ignition switch to ON.
- Check voltage between terminals TFAR (TFAL) and SG of A/C control assembly connector at each temperature. (): RHD Models

OK:**Voltage**

at 25°C (77°F): 1.8 - 2.2V

at 50°C (122°F): 0.8 - 1.2V

HINT:

As the temperature increases, the voltage decreases.

NG

Go to step 2.

OK

Proceed to next circuit inspection shown on problem symptoms table (See page N-30). However, if DTC 16 is displayed, check and replace A/C control assembly.

2 Check duct sensor.

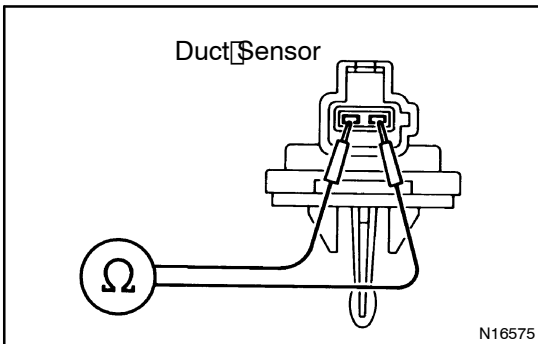

PREPARATION:

Remove duct sensor (See page AC-97).

CHECK:

Check resistance between terminals 1 and 2 of duct sensor connector at each temperature.

OK:

Resistance

at 0°C (32°F): 14.5 – 19.0 kΩ

at 25°C (77°F): 4.8 – 5.2 kΩ

at 50°C (122°F): 1.6 – 2.0 kΩ

HINT:

As the temperature increases, the resistance decreases.

NG

Replace duct sensor.

OK

3 Check harness and connector between A/C control assembly and duct sensor (See page N-30).

NG

Repair or replace harness or connector.

OK

Check and replace A/C control assembly.