

## DISASSEMBLY

### 1. REMOVE REAR END COVER

- (a) Remove the nut and terminal insulator.

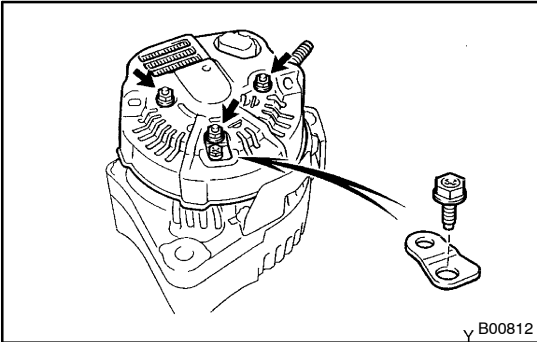

- (b) Remove the 3 nuts, bolt, plate terminal and rear end cover.

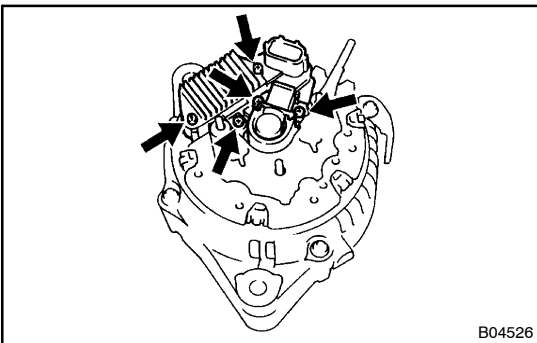

### 2. REMOVE BRUSH HOLDER AND IC REGULATOR

- (a) Remove the brush holder cover from the brush holder.
- (b) Remove the 5 screws, brush holder and IC regulator.
- (c) Remove the seal plate from the rectifier end frame.

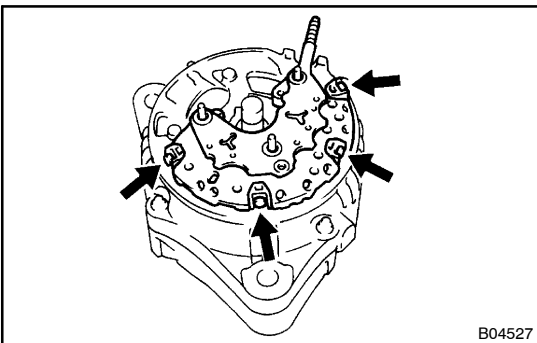

### 3. REMOVE RECTIFIER HOLDER

- (a) Remove the 4 screws and rectifier holder.
- (b) Remove the 4 rubber insulators.

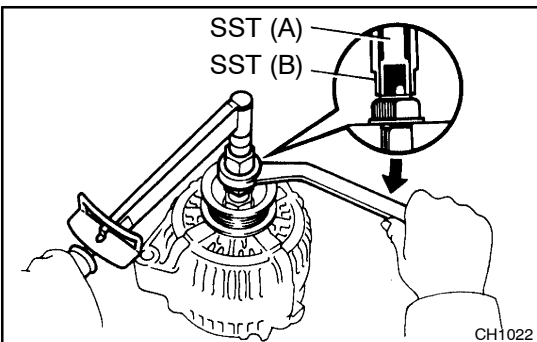

### 4. REMOVE PULLEY

- (a) Hold SST (A) with a torque wrench, and tighten SST (B) clockwise to the specified torque.  
SST 09820-63011  
**Torque: 39 N·m (400 kgf·cm, 29 ft·lbf)**
- (b) Check that SST (A) is secured to the rotor shaft.

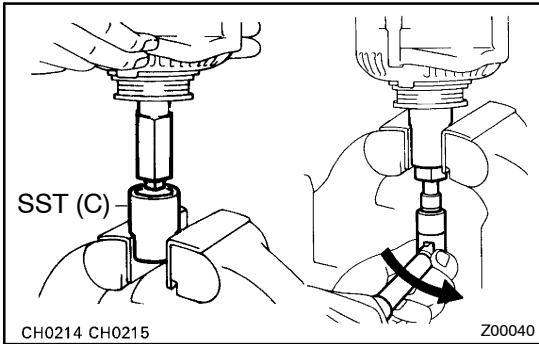

- (c) As shown in the illustration, mount SST (C) in a vise, and install the alternator to SST (C).
- (d) To loosen the pulley nut, turn SST (A) in the direction shown in the illustration.

**NOTICE:**

**To prevent damage to the rotor shaft, do not loosen the pulley nut more than one-half of a turn.**

- (e) Remove the alternator from SST (C).
- (f) Turn SST (B), and remove SST (A and B).
- (g) Remove the pulley nut and pulley.

**5. REMOVE RECTIFIER END FRAME**

- (a) Remove the 4 nuts.

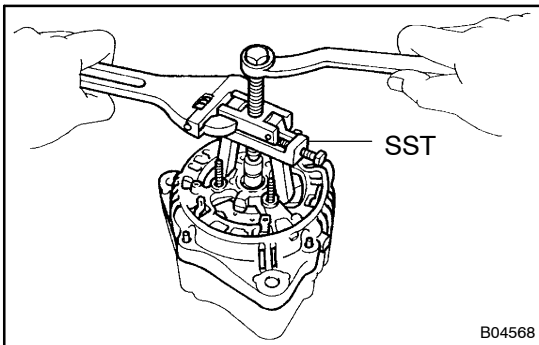
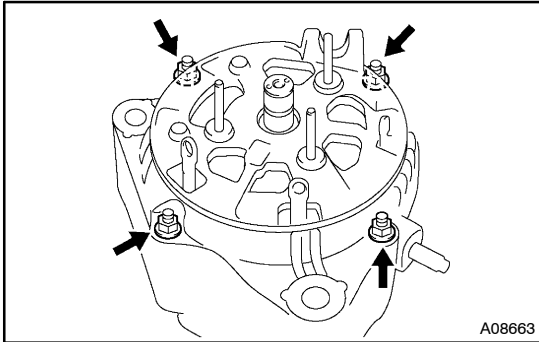

- (b) Using SST, remove the rectifier end frame.  
SST 09286-46011

- (c) Remove the alternator washer.

**6. REMOVE ROTOR FROM DRIVE END FRAME**