

LOW VIBRATION AND LOW NOISE BODY

■ SOUND ABSORBING AND VIBRATION DAMPING MATERIALS

- Vibration-damping materials, sound-absorbing materials, and sound-insulating materials have been effectively allocated to various areas, and thick glass has been adopted for the windows to realize an excellent level of quietness.

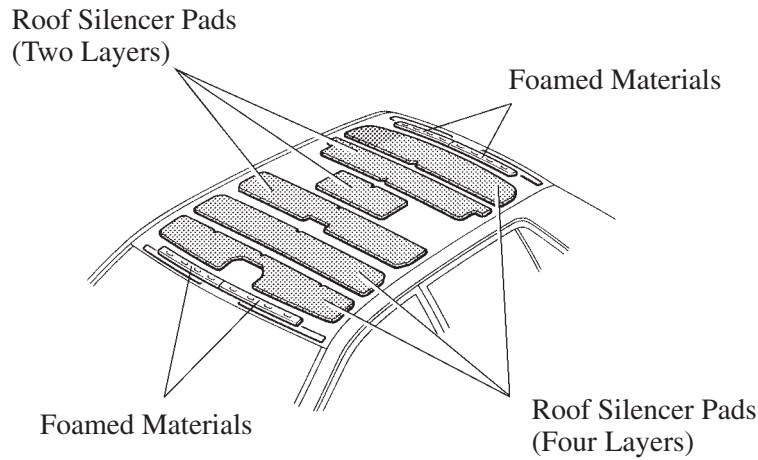

162B006

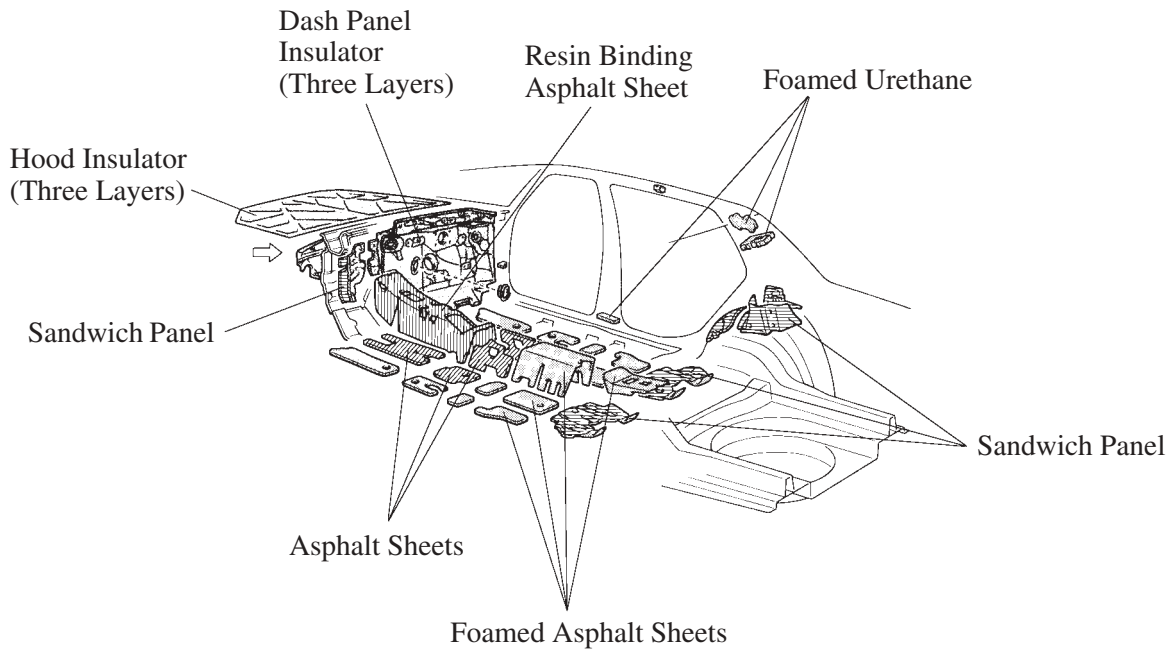

162B007

 : Resin Foamed Material
 : Foamed Material

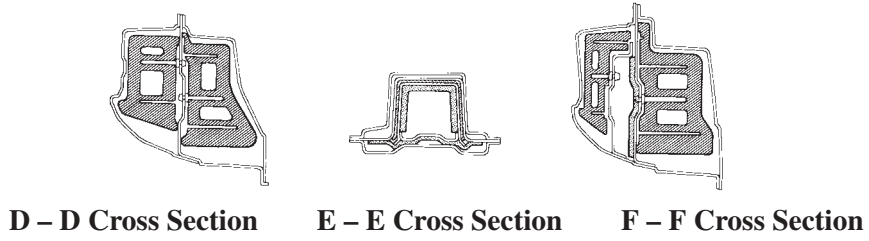
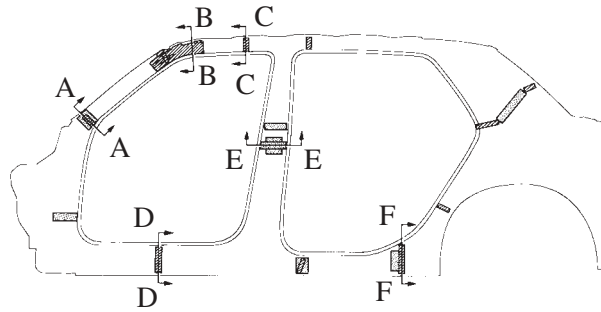

162B008

BO

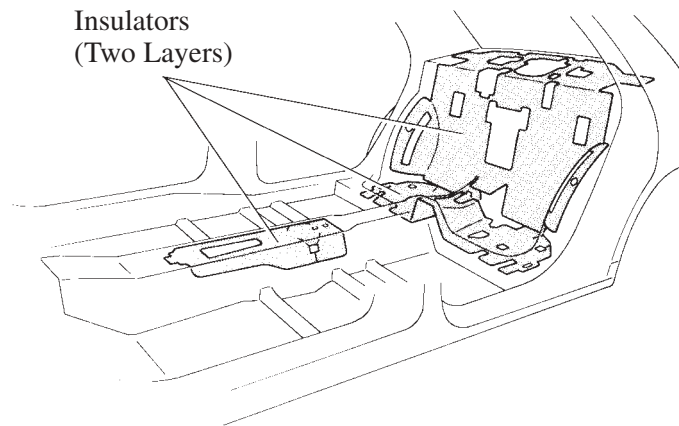

162B009

- Vibration-damping sheets are provided in the door panels to dampen the vibration of the panel when opening or closing the door. In particular, the annoying sound when closing the door is reduced.

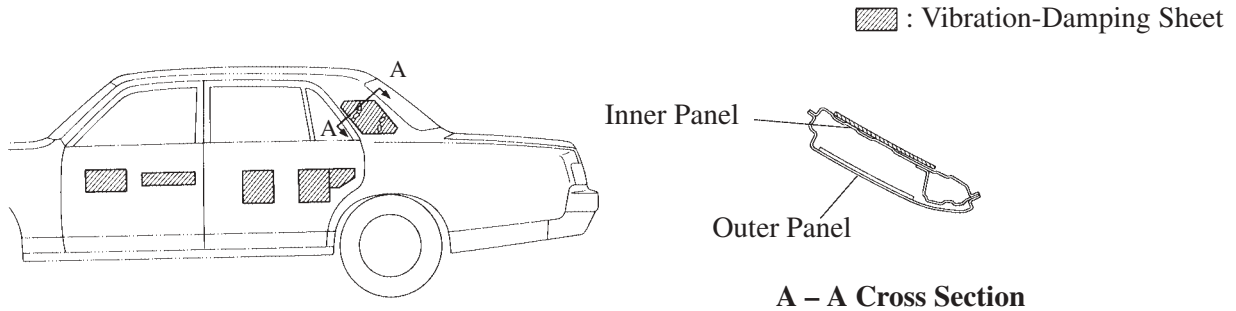

162BO10

WEATHER STRIP

The weather strip around the doors provides multiple seals to reduce the wind noise created in the vicinity of the door.

Weather Strips

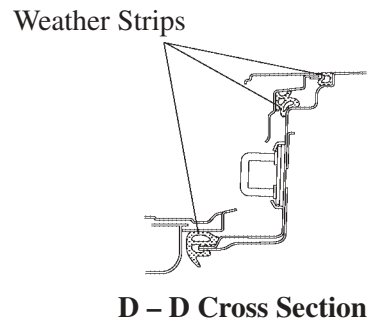
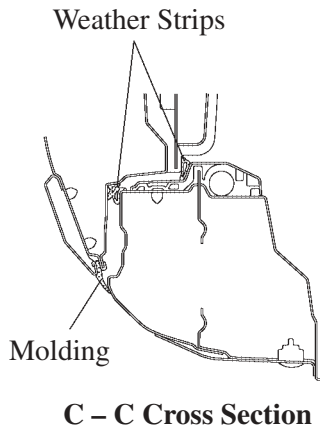
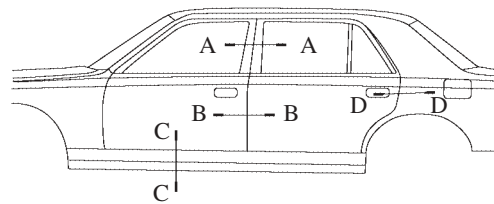
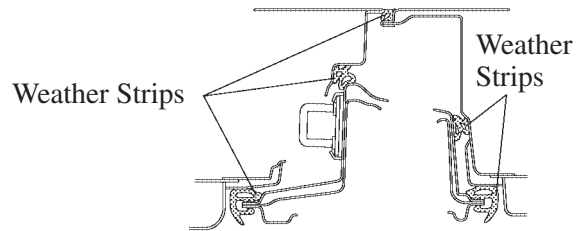
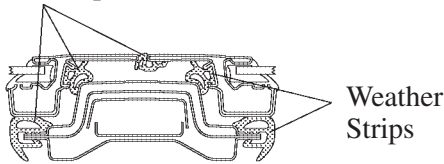

162BO14