

DTC	B1242 / 42	Wireless door lock tuner circuit malfunction
------------	-------------------	---

CIRCUIT DESCRIPTION

This DTC is output when GND short of RDA terminal is detected.

DTC No.	DTC Detecting Condition	Trouble Area
B1242/42	GND short of RDA terminal	<ul style="list-style-type: none"> • Wireharness • Wireless door lock tuner • Body ECU

WIRING DIAGRAM

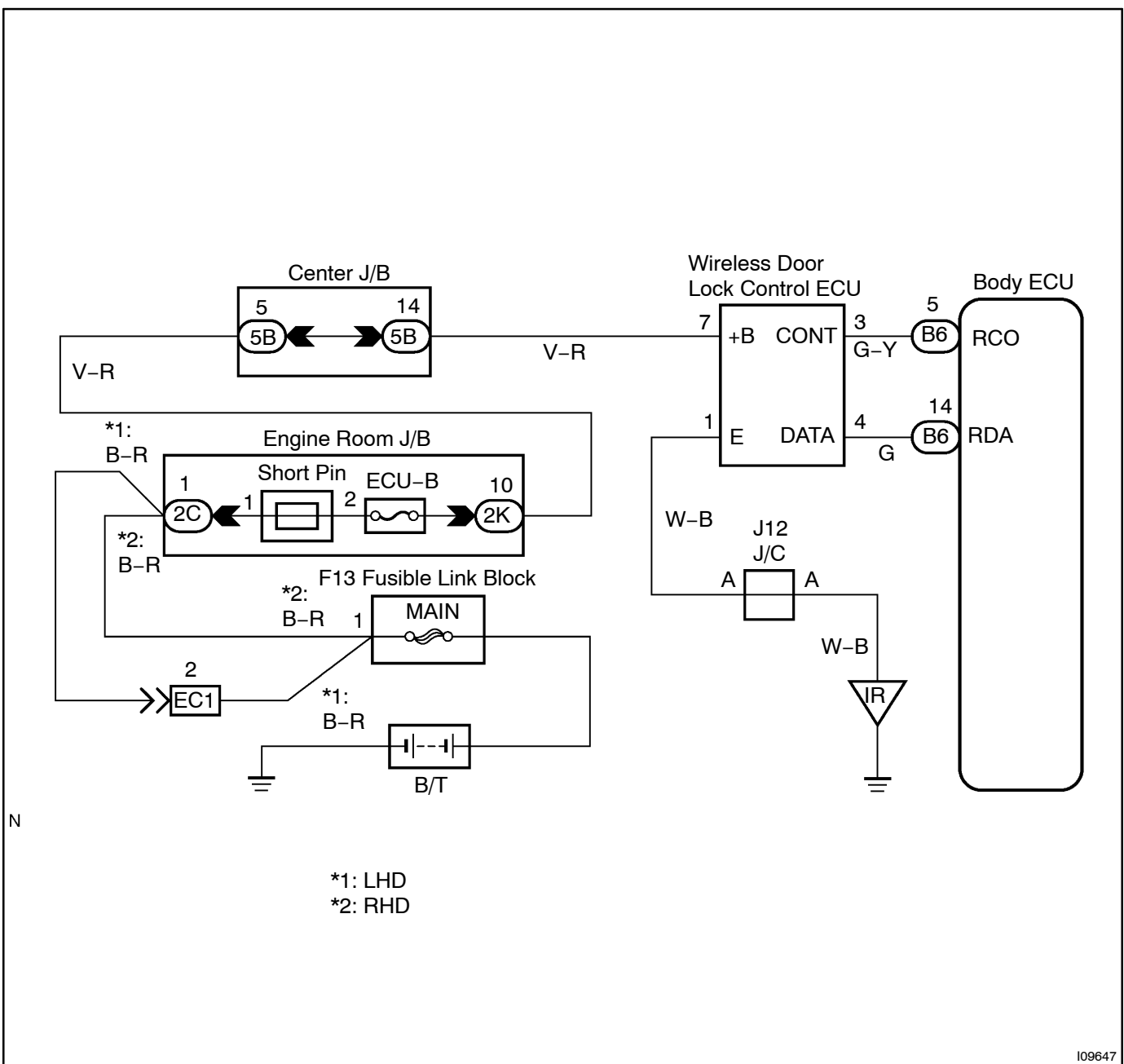

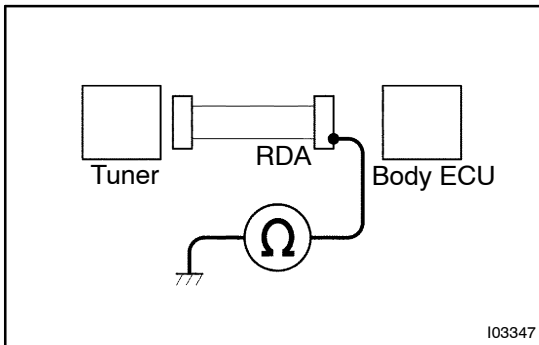
INSPECTION PROCEDURE**1 Check wireharness.****PREPARATION:**

Disconnect the connector of tuner and body ECU.

CHECK:

Check the continuity between wireharness and body ground.

OK:

No continuity.

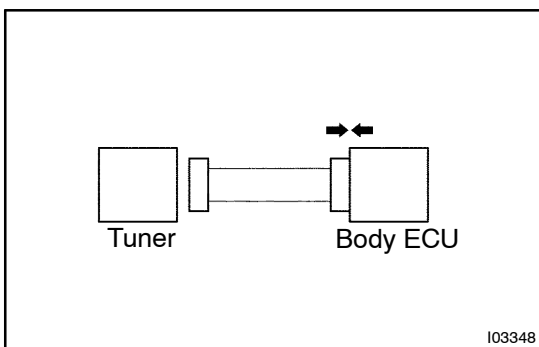
NG**Repair or replace the wireharness.****OK****2 Check body ECU.****PREPARATION:**

Connect the connector of body ECU.

CHECK:

Check the DTC.

OK:

B1242/42 is not output.

NG**Replace the body ECU.****OK****Replace the tuner.**