

## REMOVAL

### 1. REMOVE INSTRUMENT CLUSTER FINISH PANEL ASSEMBLY

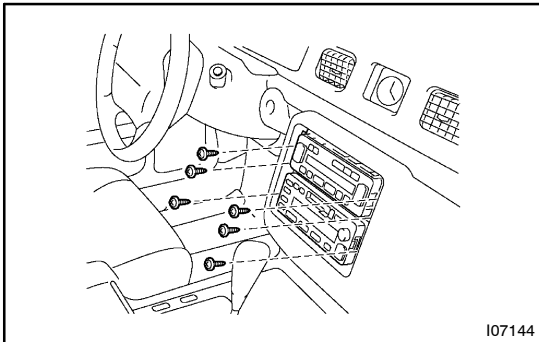

### 2. REMOVE A/C CONTROL ASSEMBLY

- (a) Remove the 6 screws.
- (b) Pull out the radio receiver & A/C control assembly, then disconnect the connector.

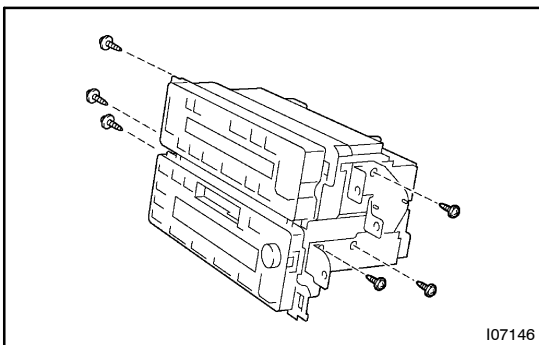

- (c) Remove the 6 screws and 2 radio brackets.
- (d) Separate the radio receiver and A/C control assembly.