

## REASSEMBLY

### 1. INSTALL OIL SEAL RING

- (a) Coat the 3 oil seal rings with ATF.
- (b) Install the 3 oil seal rings to the forward clutch drum groove, then snug them down by squeezing their ends together.

#### NOTICE:

**Do not spread the ring ends more than necessary.**

#### HINT:

After installing the oil seal rings, check that they rotate smoothly.

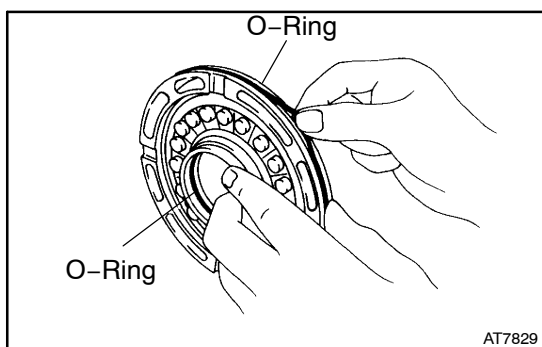

### 2. INSTALL FORWARD CLUTCH PISTON

- (a) Coat 2 new O-rings with ATF and install them on the forward clutch piston.

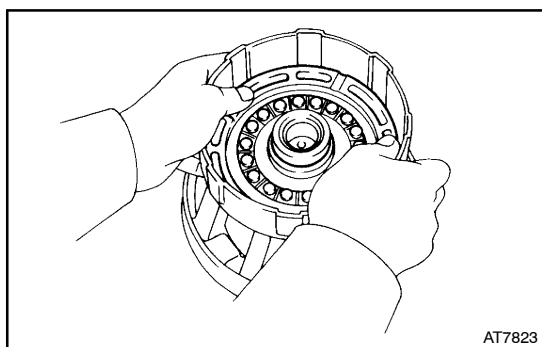

- (b) Be careful not to damage the O-rings, press the clutch piston into the forward clutch drum with both hands.

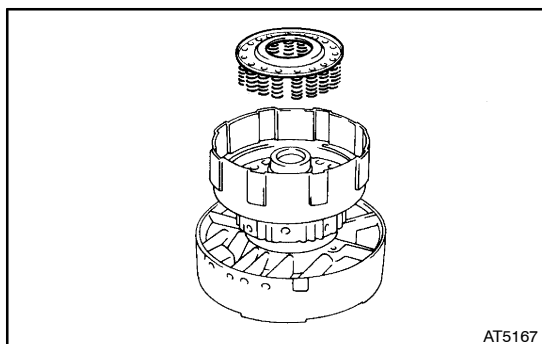

### 3. INSTALL PISTON RETURN SPRING

- (a) Install the piston return spring.

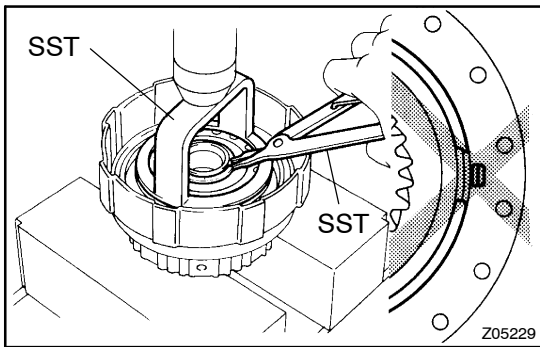

- (b) Place SST on the spring retainer, and compress the re-  
turn spring with a press.  
SST 09350-30020 (09350-07040)
- (c) Using SST, install the snap ring.  
SST 09350-30020 (09350-07070)

**NOTICE:**

**Be sure the end gap of the snap ring is not aligned with the spring retainer claw.**

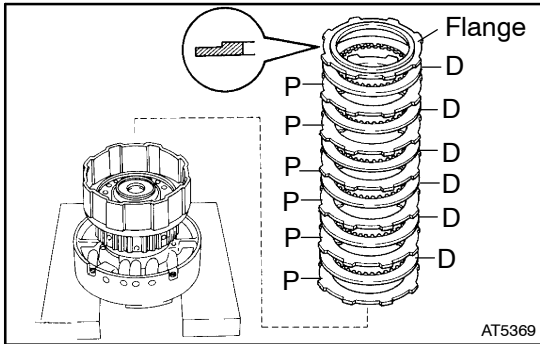

**4. INSTALL PLATE, DISC AND FLANGE**

- (a) Install the 6 plates and discs.  
**Install in order: P = Plate, D = Disc**  
**P - D - P - D - P - D - P - D - P - D - P - D**
- (b) Then install the flange, with the flat end facing downward.

**HINT:**

There are 6 different thickness for the flange.

**Flange thickness:**

No.	Thickness mm (in.)	No.	Thickness mm (in.)
42	4.0 (0.157)	45	3.4 (0.134)
44	3.8 (0.150)	60	3.2 (0.126)
62	3.6 (0.142)	61	3.0 (0.118)

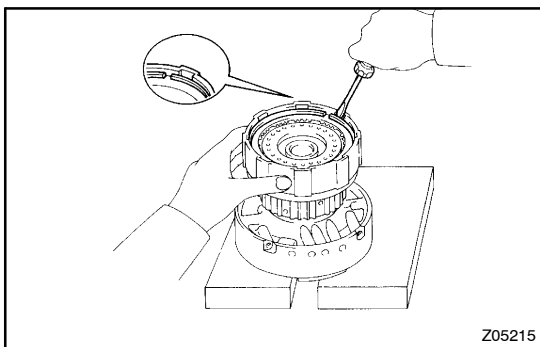

- (c) Using a screwdriver, install the snap ring.

**NOTICE:**

**Be sure the end gap of the snap ring is not aligned with the cutout portion of the forward clutch drum.**

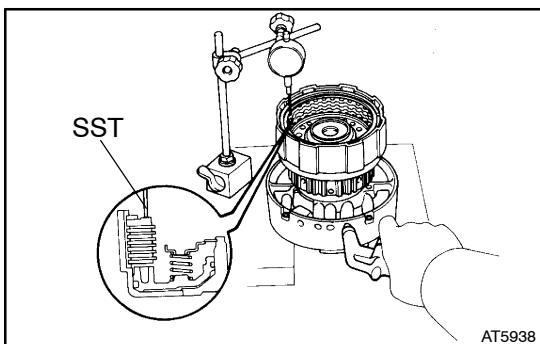

**5. CHECK PISTON STROKE OF FORWARD CLUTCH**

Using SST and a dial indicator, measure the forward clutch piston stroke while applying and releasing compressed air (186 - 206 kPa, 1.9 - 2.1 kgf/cm<sup>2</sup>, 27 - 30 psi).

SST 09350-30020 (09350-06120)

**Piston stroke: 0.70 - 1.00 mm (0.028 - 0.039 in.)**

If the piston stroke is less than the limit, parts may have been assembled incorrectly, check and reassemble again.