

## Door unlock detection switch

### CIRCUIT DESCRIPTION

The door unlock detection switch is built in the door lock motor assembly. This switch is ON when the door lock knob is in the unlock position and OFF when the lock knob is in the lock position. The ECU detects the door lock knob conditions is this circuit. It is used as one of the operating conditions for the key confinement prevention function.

### WIRING DIAGRAM

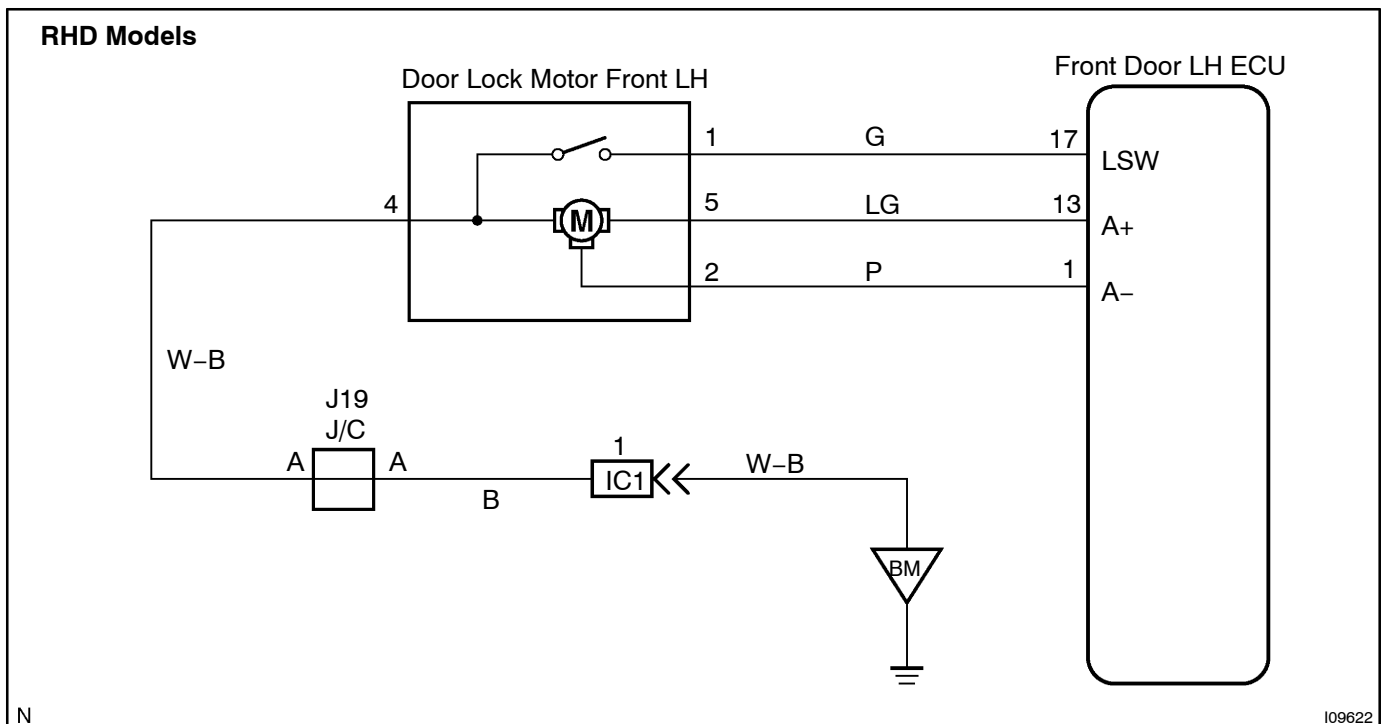
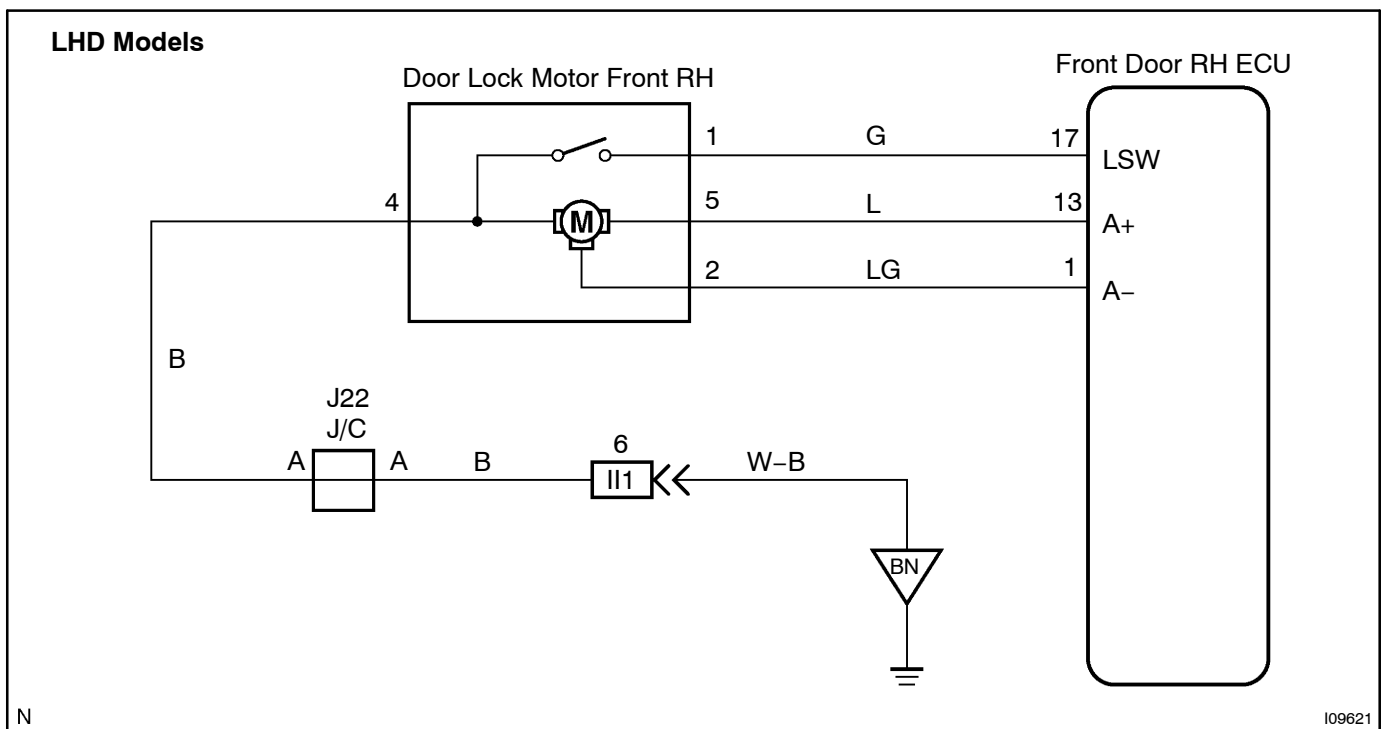

**INSPECTION PROCEDURE**

1 Check door unlock detection switch (See page BE-92).

NG

Replace the door lock motor.

OK

2 Check wireharness and connector between door unlock detection switch and passenger door ECU (See page IN-30).

NG

Repair or replace wireharness or connector.

OK

Proceed to next circuit inspection shown on problem symptoms table (See page DI-584).