

DTC	B1175/97	Short in Rear Side Squib (LH) Circuit
------------	-----------------	--

CIRCUIT DESCRIPTION

The rear side squib (LH) circuit consists of the airbag sensor assembly and rear side airbag assembly (LH). It causes the SRS to deploy when the SRS deployment conditions are satisfied.

For details of the function of each component, see OPERATION on page RS-3.

DTC B1175/97 is recorded when a short is detected in the rear side squib (LH) circuit.

DTC No.	DTC Detecting Condition	Trouble Area
B1175/97	<ul style="list-style-type: none"> • Short circuit between RL+ wire harness and RL- wire harness of squib • Rear side squib (LH) malfunction • Airbag sensor assembly malfunction 	<ul style="list-style-type: none"> • Rear side airbag assembly (LH) • Airbag sensor assembly • Wire harness

WIRING DIAGRAM

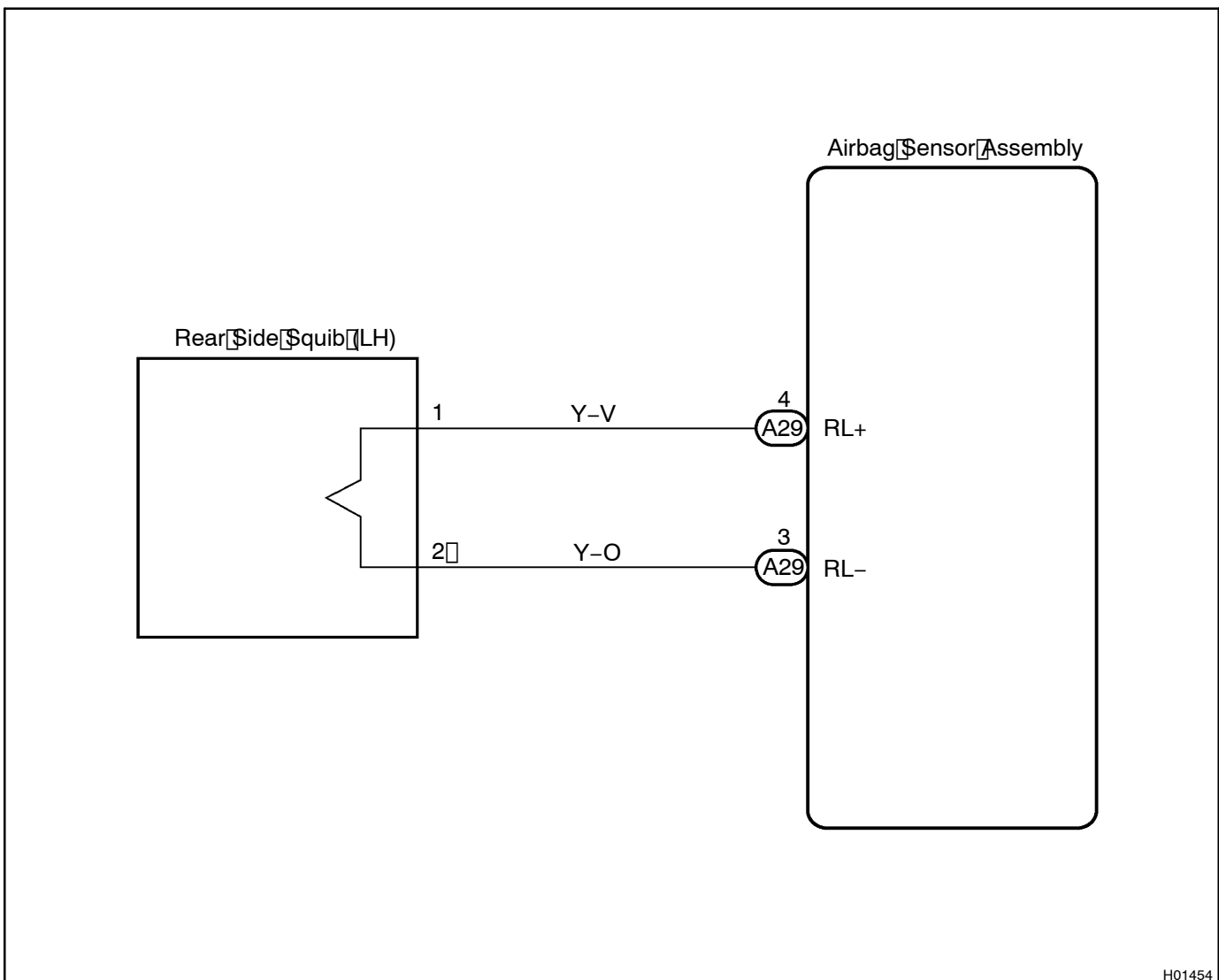

INSPECTION PROCEDURE

1 Prepare for inspection. (See step 1 on page DI-368)

2 Check rear side squib (LH) circuit.

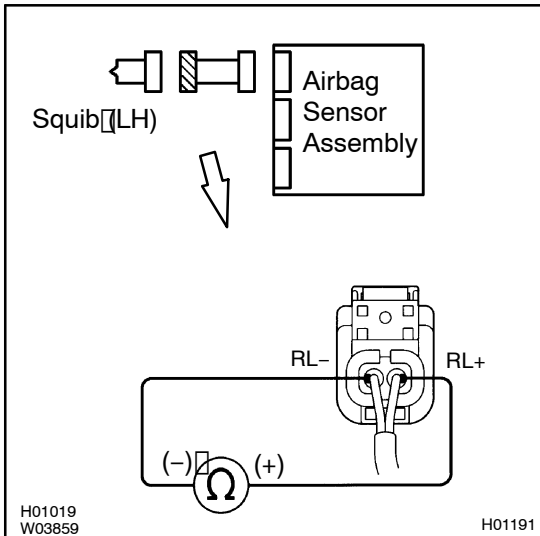
**PREPARATION:**

Release the airbag activation prevention mechanism of the connector (on the airbag sensor assembly side) between the airbag sensor assembly and the rear side airbag assembly (LH). (See page DI-229)

CHECK:

For the connector (on the rear side airbag assembly side) between the rear side airbag assembly (LH) and the airbag sensor assembly, measure the resistance between RL+ and RL-.

OK:

Resistance: 1 MΩ or Higher

NG

Repair or replace harness or connector between rear side airbag assembly (LH) and airbag sensor assembly.

OK

3 Check airbag sensor assembly.

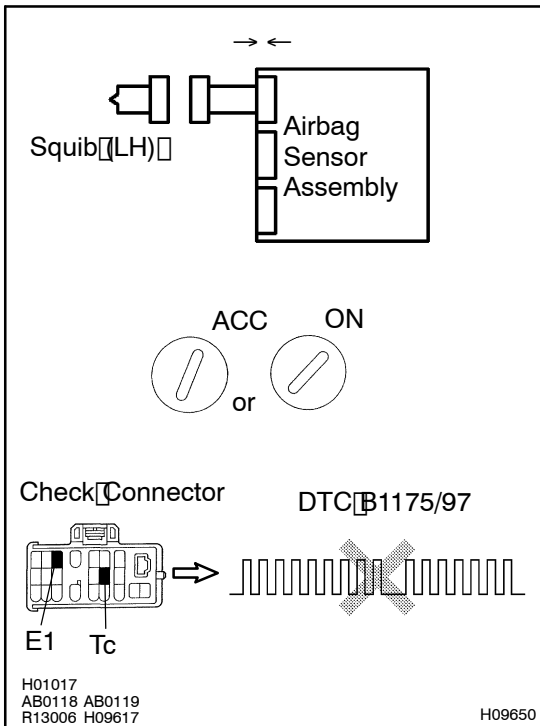

PREPARATION:

- Connect the connector to the airbag sensor assembly.
- Connect negative (-) terminal cable to the battery, and wait at least for 2 seconds.

CHECK:

- Turn ignition switch to ACC or ON and wait at least for 20 seconds.
- Clear DTC stored in memory. (See page DI-229)
- Turn ignition switch to LOCK, and wait at least for 20 seconds.
- Turn ignition switch to ACC or ON, and wait at least for 20 seconds.
- Check DTC. (See page DI-229)

OK:

DTC B1175/97 is not output.

HINT:

Codes other than code B1175/97 may be output at this time, but they are not relevant to this check.

NG

Replace airbag sensor assembly.

OK

4 Check rear side squib (LH).

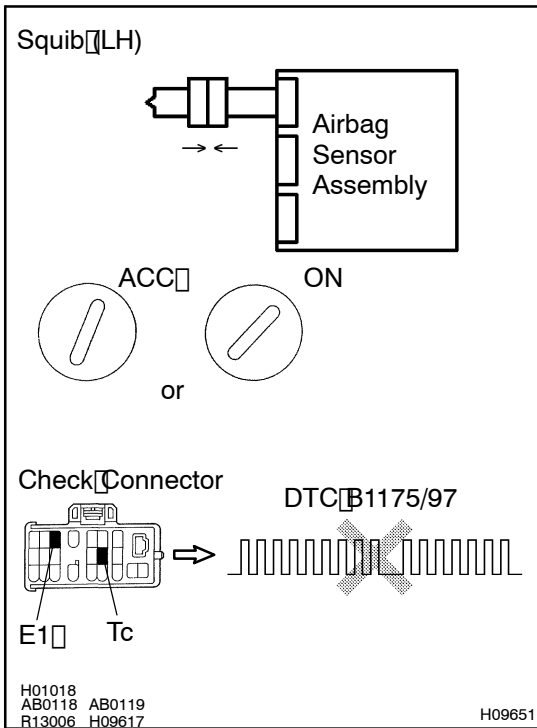

PREPARATION:

- Turn ignition switch to LOCK.
- Disconnect negative (-) terminal cable from the battery, and wait at least for 90 seconds.
- Connect the rear side airbag assembly (LH) connector.
- Connect negative (-) terminal cable to the battery, and wait at least for 2 seconds.

CHECK:

- Turn ignition switch to LOCK, and wait at least for 20 seconds.
- Turn ignition switch to ACC or ON, and wait at least for 20 seconds.
- Clear DTC stored in memory. (See page DI-229)
- Turn ignition switch to LOCK, and wait at least for 20 seconds.
- Turn ignition switch to ACC or ON, and wait at least for 20 seconds.
- Check DTC. (See page DI-229)

OK:

DTC B1175/97 is not output.

HINT:

Codes other than code B1175/97 may be output at this time, but they are not relevant to this check.

NG

Replace rear side airbag assembly (LH).

OK

From the results of the above inspection, the malfunctioning part can now be considered normal. To make sure of this, use the simulation method to check.