

<b>DTC</b>	<b>82</b>	<b>Stop Light Switch Circuit</b>
------------	-----------	----------------------------------

**CIRCUIT DESCRIPTION**

When the brake pedal is depressed, the stop light switch comes on and battery voltage is applied to terminal STP of ECU. This signal is used by the ECU as one of the starting conditions for anti-dive control.

DTC No.	DTC Detecting Condition	Trouble Area
82	Stop light switch signal does not change	<ul style="list-style-type: none"> <li>• Stop light switch</li> <li>• Stop light switch circuit</li> <li>• Body ECU</li> <li>• Suspension control ECU</li> </ul>

**WIRING DIAGRAM**

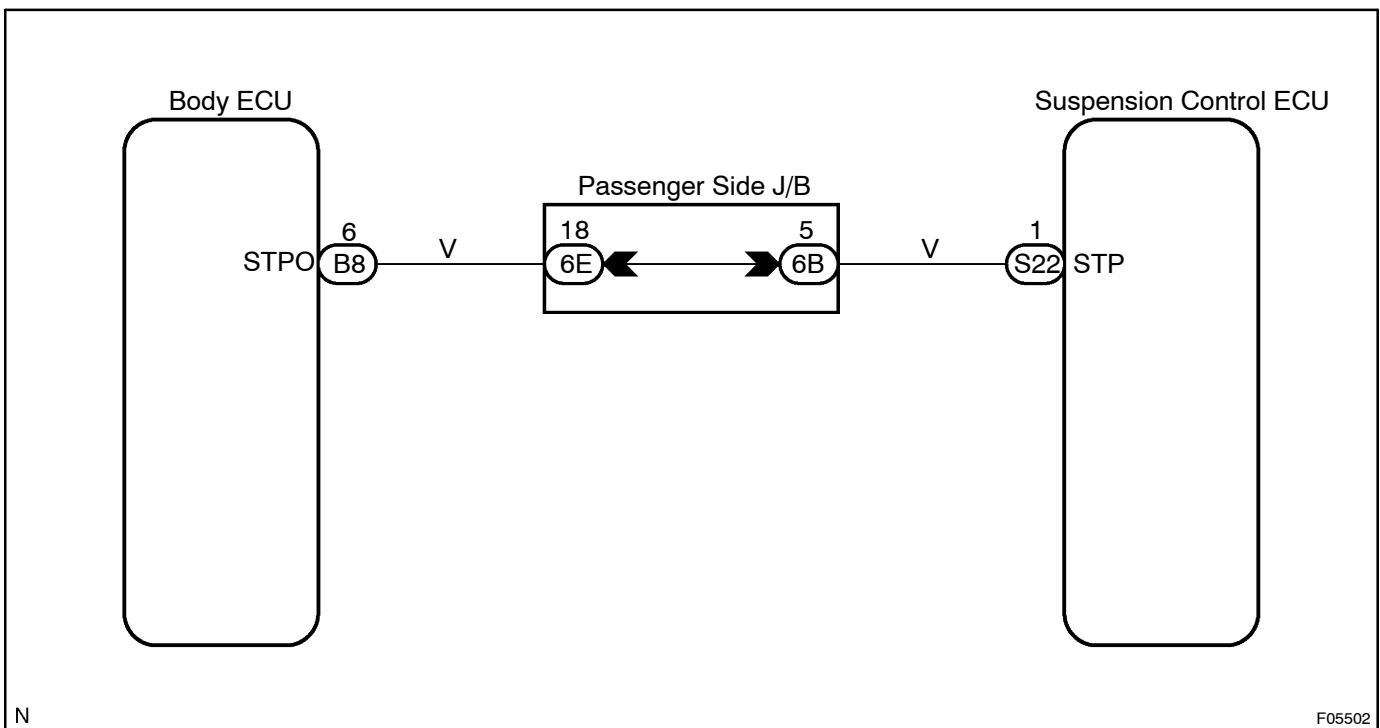

N

F05502

## INSPECTION PROCEDURE

## 1 Check operation of stop light.

**CHECK:**

Check that the stop light comes on when the brake pedal is depressed and turns off when the brake pedal is released.

NG

Check stop light circuit (See page BE-2).

OK

## 2 Check voltage between terminal STP of suspension control ECU connector and body ground.

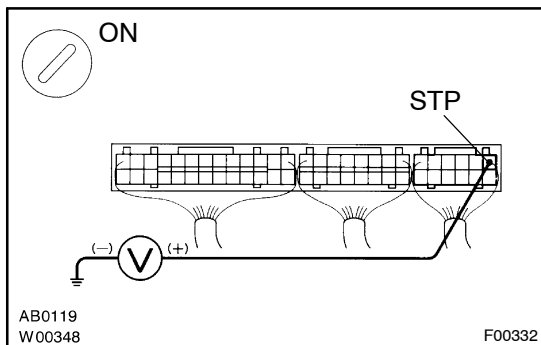
**PREPARATION:**

- (a) LHD:  
Remove the RH scuff plate, instrument panel under cover No. 2, glove compartment and CD changer (See page BO-96).
- (b) RHD:  
Remove the RH scuff plate, instrument panel under cover No. 1, instrument panel lower pad and heater to register duct No. 2 (See page BO-96).

**CHECK:**

- (a) Turn the ignition switch ON.
- (b) Measure the voltage between terminal STP of suspension control ECU connector and body ground, when the brake pedal is released and depressed.

**OK:**

Brake pedal	Voltage
Released	0 - 1.5 V
Depressed	10 - 14 V

OK

Proceed to next circuit inspection shown on problem symptoms table (See page DI-79).

NG

3

Check for open and short circuit in harness and connector between suspension control ECU and body ECU (See page IN-30).

NG

Repair or replace harness or connector.

OK

Check and replace suspension control ECU.