

## FRONT FENDER APRON (ASSY)

REMOVAL (With the radiator support side removed.)

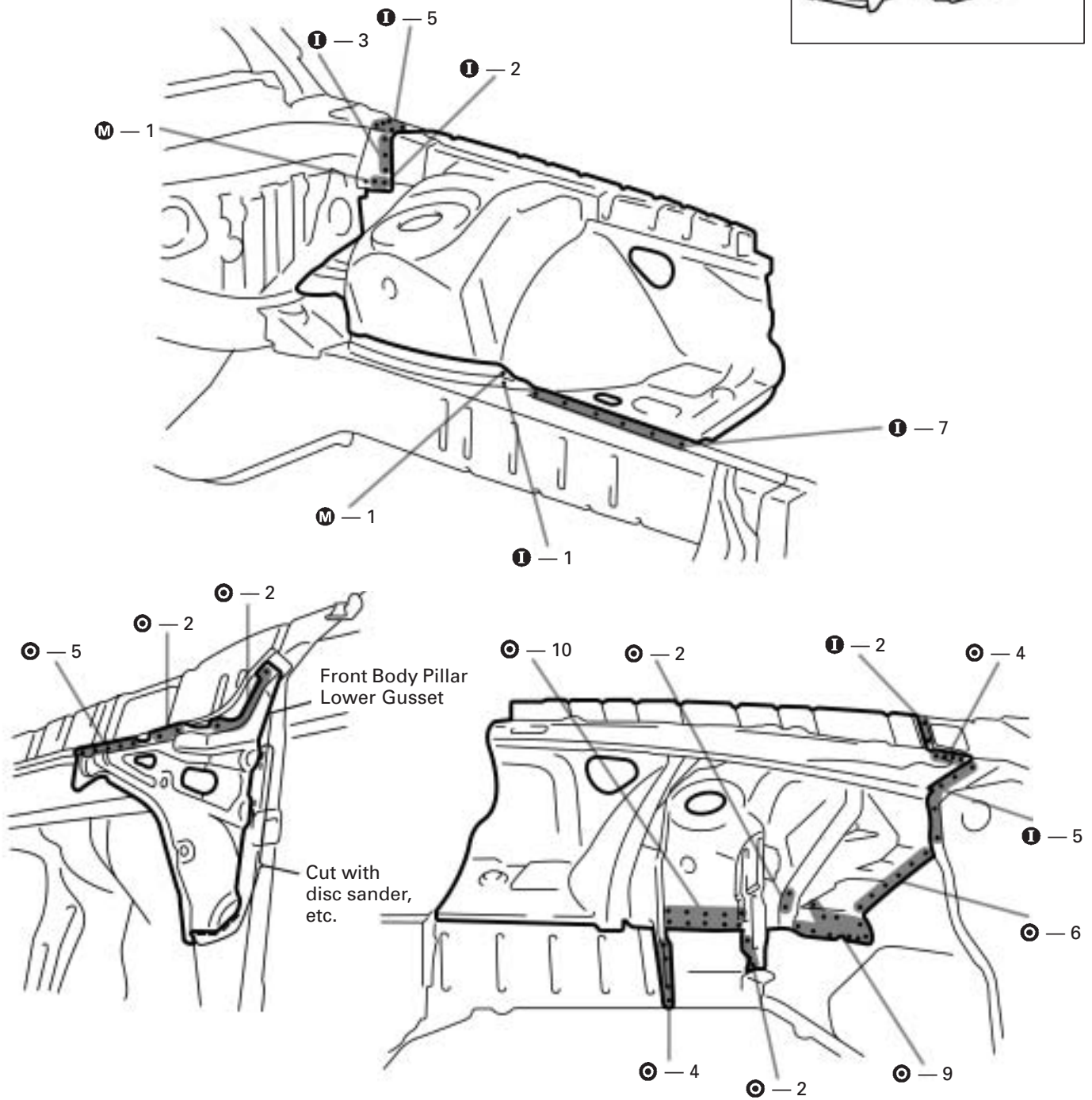
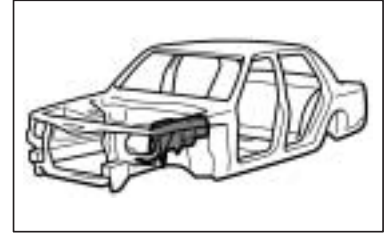

1. After removing the front body pillar lower gusset, remove the front fender apron.

INSTALLATION

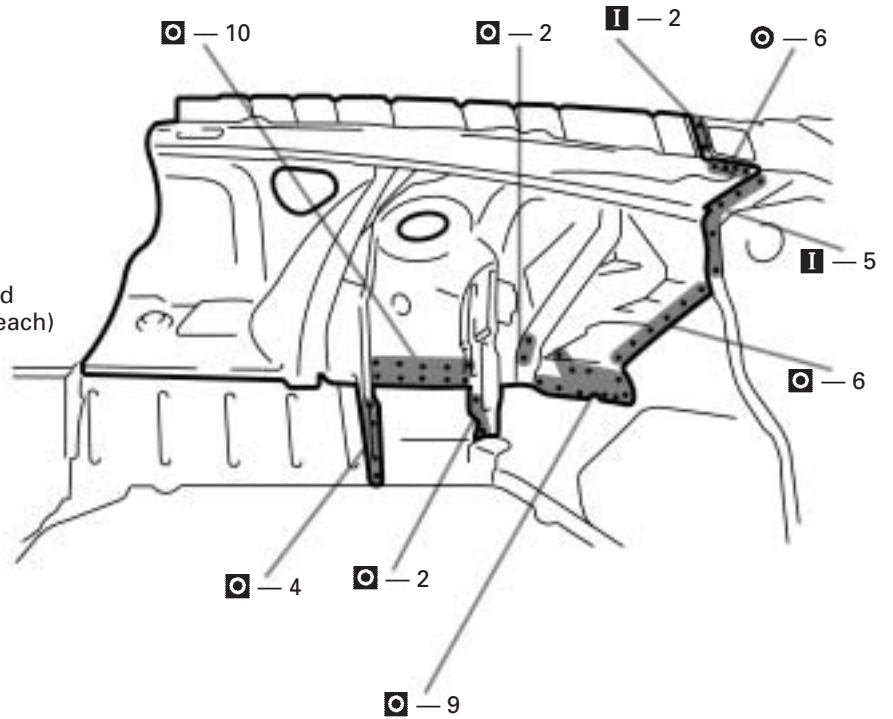
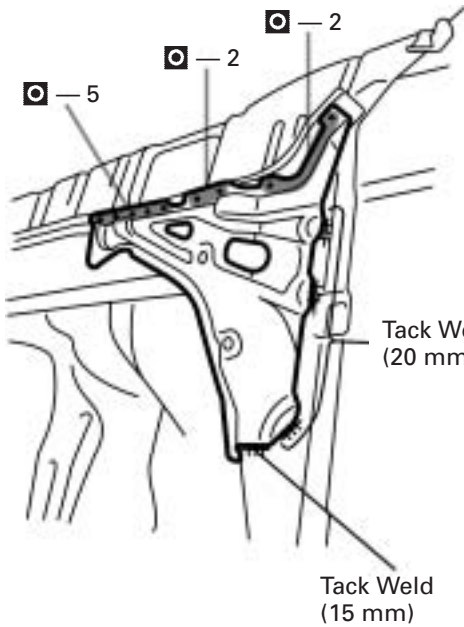
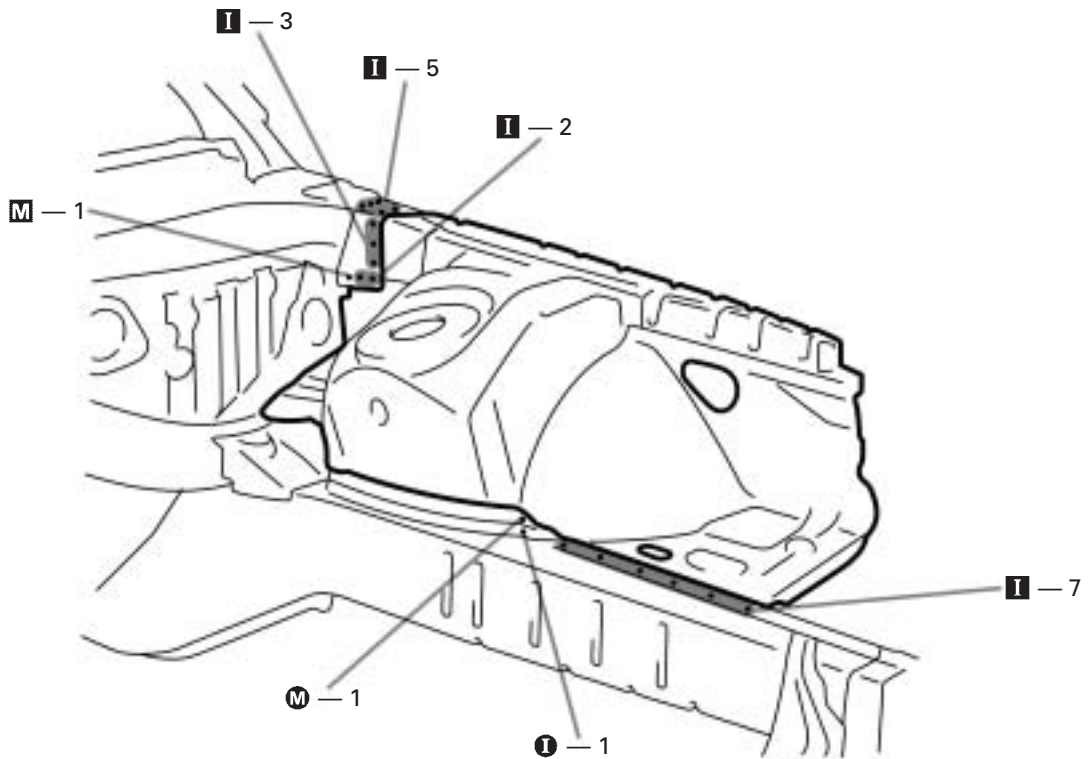

mm	in.
15	0.59
20	0.79

1. Measurements must be accurate with the body dimension diagram, as this affects the front wheel alignment.
2. Temporarily install the front fender and hood, and check the fit.