

FIRST AND REVERSE BRAKE ASSEMBLY

1. INSTALL NO.1 BRAKE PISTON

- (a) Coat the 3 new O-rings with ATF.
- (b) Install the 2 O-rings on No.1 brake piston.
- (c) Install the O-ring on the reaction sleeve.
- (d) Install the No.1 brake piston to the reaction sleeve.

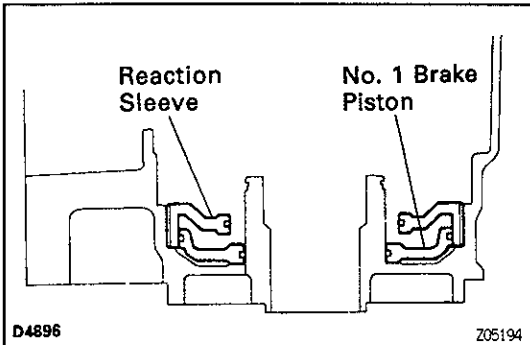

2. INSTALL REACTION SLEEVE AND NO.1 BRAKE PISTON TO TRANSMISSION CASE

With the No.1 brake piston underneath (the rear side), install the brake reaction sleeve and No.1 brake piston to the transmission case.

NOTICE: Be careful not to damage the O-rings.

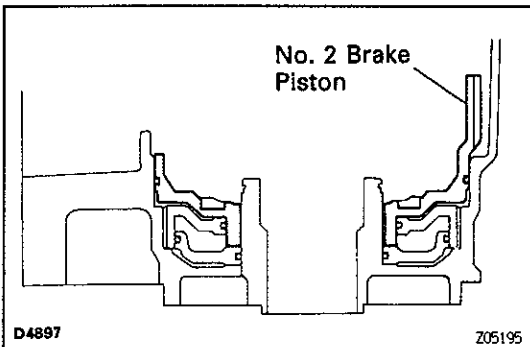

3. INSTALL NO.2 BRAKE PISTON

- (a) Coat the a new O-ring with ATF.
- (b) Install the O-ring on No.2 brake piston.
- (c) With the spring seat of the piston upwards (the front side), place the piston in the transmission case.

NOTICE: Be careful not to damage the O-rings.

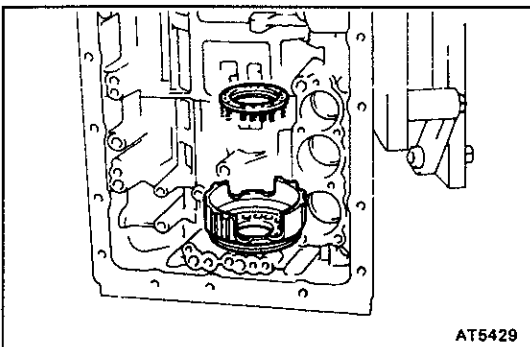

- (d) Place the piston return spring onto the No.2 brake piston.

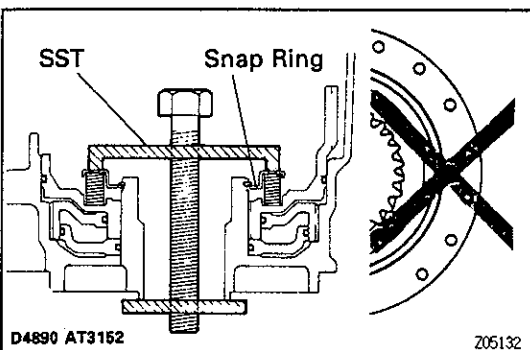

4. INSTALL PISTON RETURN SPRING

- (a) Place SST on the spring retainer and compress the return spring.
SST 09350-30020 (09350-07050)
- (b) Using SST, install the snap ring.
SST 09350-30020 (09350-07070)

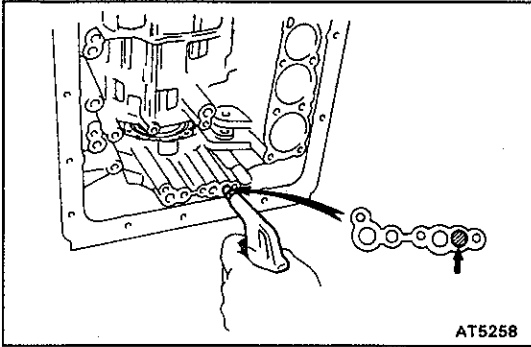

5. CHECK PISTON STROKE OF FIRST AND REVERSE BRAKE

Make sure the first and reverse brake pistons move smoothly when applying and releasing the compressed air into the transmission case.

AT