

<b>DTC</b>	<b>P1300/14</b>	<b>Igniter Circuit Malfunction</b>
------------	-----------------	------------------------------------

## CIRCUIT DESCRIPTION

A DIS (Direct Ignition System) has been adopted. The DIS improves the ignition timing accuracy, reduces high-voltage loss, and enhances the overall reliability of the ignition system by eliminating the distributor. The DIS is a 1-cylinder ignition system which ignites one cylinder with one ignition coil. In the 1-cylinder ignition system, the one spark plug is connected to the end of the secondary winding. High voltage generated in the secondary winding is applied directly to the spark plug. The spark of the spark plug passes from the center electrode to the ground electrode.

The engine ECU determines ignition timing and outputs the ignition signals (IGT) for each cylinder. Based on IGT signals, the power transistors in the igniter cuts off the current to the primary coil in the ignition coil the counter-electromotive force is supplied to the spark plug that are connected to the end of the secondary coil. At the same time, the igniter also sends an ignition confirmation signal (IGF) as a fail-safe measure to the engine ECU.

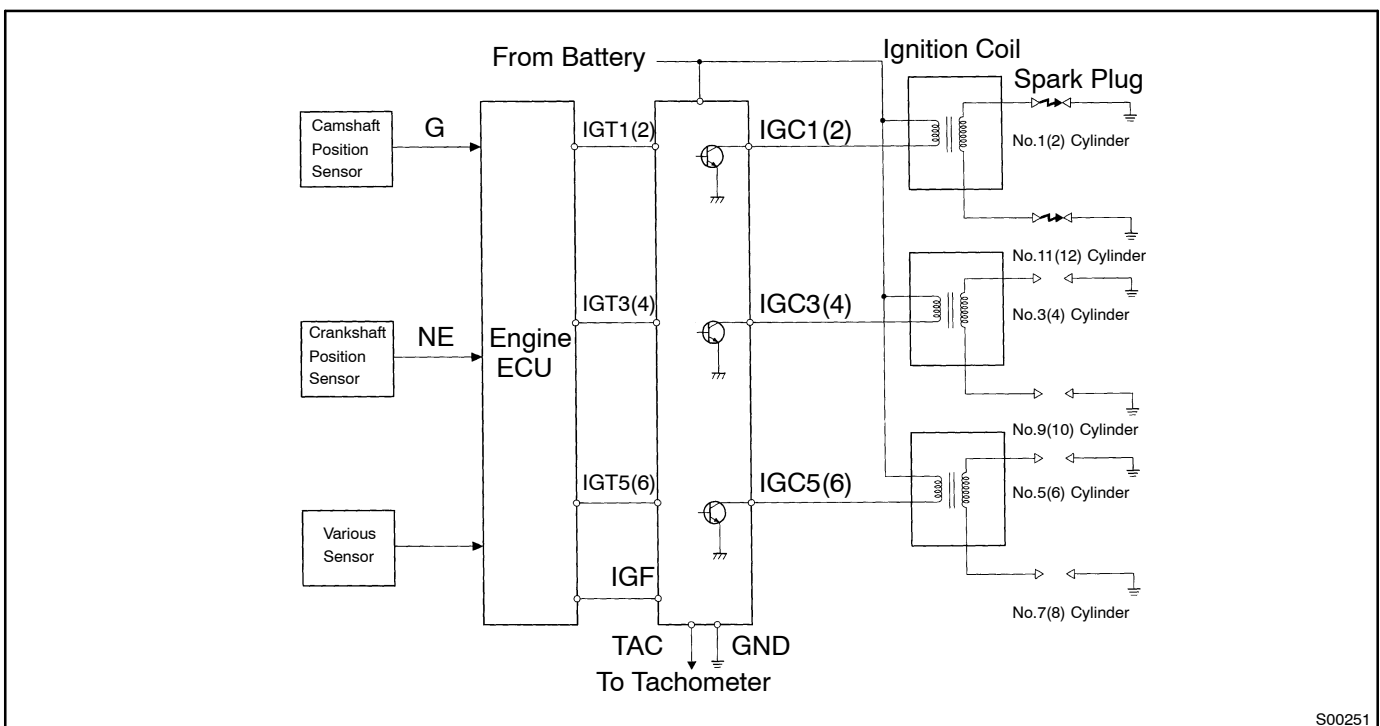

S00251

DTC No.	DTC Detecting Condition	Trouble Area
P1300/14	No IGF signal to engine ECU while engine is running.	<ul style="list-style-type: none"> <li>• Open or short in IGF or IGT circuit from igniter to engine ECU</li> <li>• Igniter</li> <li>• EFI main relay</li> <li>• Engine ECU</li> </ul>

WIRING DIAGRAM

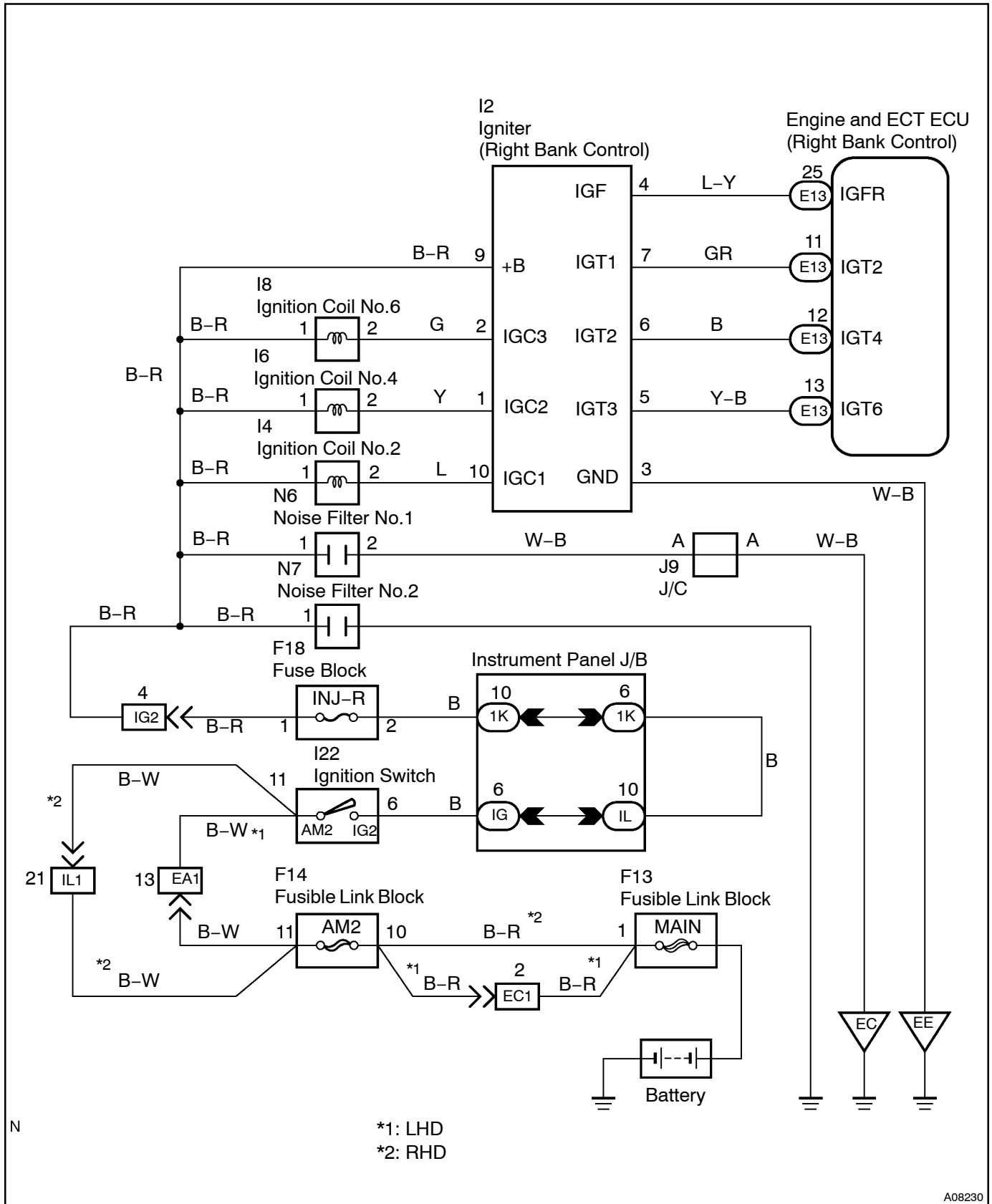

## INSPECTION PROCEDURE

### HINT:

- LH and RH bank engine ECU detect this DTC code respectively. The inspection procedures are same for both LH and RH bank engine ECU and described in this manual. Even though terminal name and part name on the side of RH bank are described in parenthesis, perform the inspection for only ECU that has detected DTC.
- Read freeze frame data using hand-held tester. Because freeze frame records the engine conditions when the malfunction is detected, when troubleshooting it is useful for determining whether the vehicle was running or stopped, the engine warmed up or not, the air-fuel ratio lean or rich, etc. at the time of the malfunction.

**1 Check spark plug and spark (See Pub. No. RM677E, page IG-1).**

**NG**

**Go to step 4.**

**OK**

**2 Check for open and short in harness and connector in IGF signal circuit between engine ECU and ignition coil with igniter (See page N-20).**

**NG**

**Repair or replace harness or connector.**

**OK**

- 3** Disconnect ignition coil with igniter connector and check voltage between terminals IGF (IGFR) of engine ECU connector and body ground.

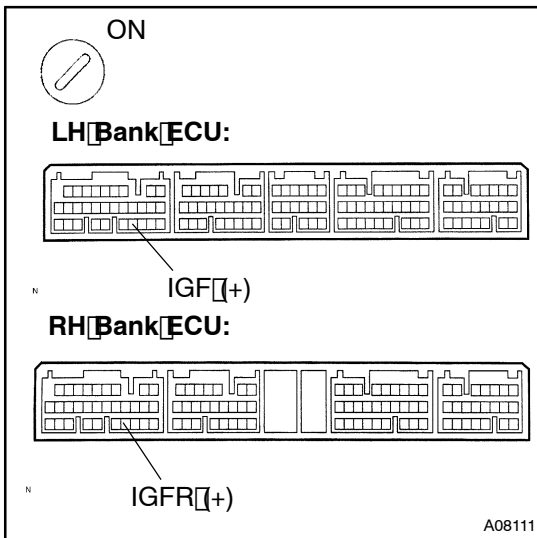
**PREPARATION:**

- (a) Disconnect the igniter connector.  
 (b) Remove the engine ECU with connectors still connected.  
 (c) Turn the ignition switch to ON.

**CHECK:**

Measure voltage between terminals IGF of the engine ECU connector and body ground.

**OK:**

Voltage: 4.5 - 5.5V

OK

Replace igniter.

NG

Check and replace engine ECU  
 (See page IN-20).

- 4** Check for open and short in harness and connector in IGT1, 3, 5 (2, 4, 6) signal circuit between engine ECU and ignition coil with igniter (See page IN-20).

NG

Repair or replace harness or connector.

OK

**5** Check voltage between terminals IGT1, 3, 5 (2, 4, 6) of engine ECU connector and body ground.

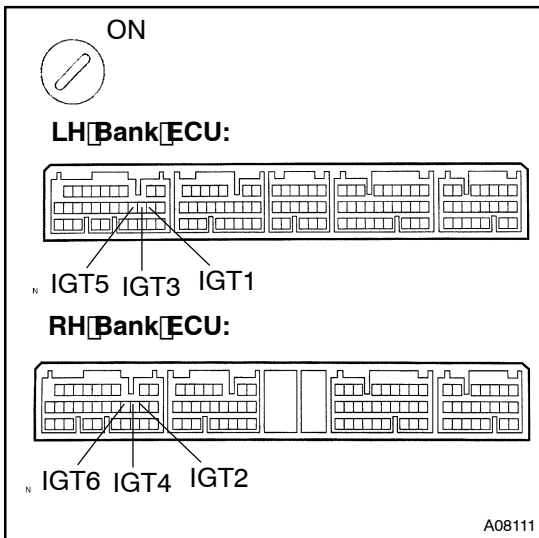

**PREPARATION:**

Remove the engine ECU with connectors still connected.

**CHECK:**

Measure voltage between terminals IGT1, 3, 5 (2, 4, 6) of the engine ECU connector and body ground when engine is cranked.

**OK:**

**Voltage: More than 0.1 V and less than 4.5 V**

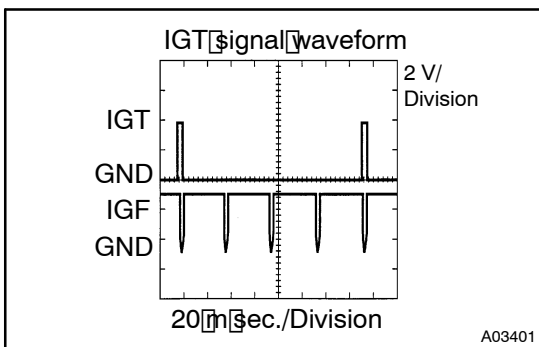

**Reference: INSPECTION USING OSCILLOSCOPE**

During cranking or idling, check waveform between terminals IGT1, 3, 5 (2, 4, 6) and E1 of the engine ECU connector.

**HINT:**

Correct waveform appears as shown, with rectangle waves.

**NG**

**Check and replace engine ECU**  
(See page N-20).

**OK**

**6** Disconnect connector and check voltage between terminals IG1, 3, 5 (2, 4, 6) of engine ECU connector and body ground.

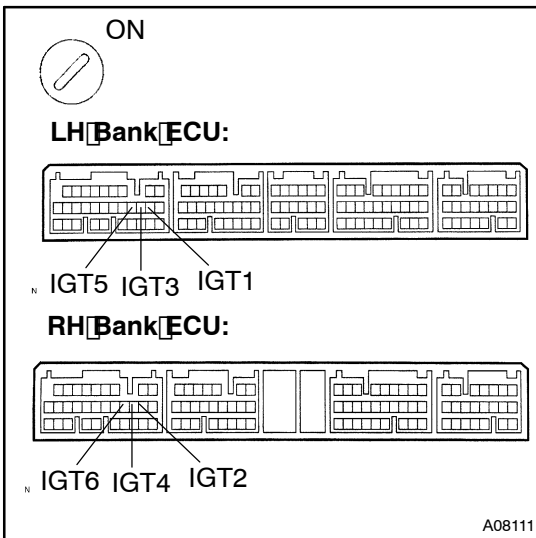
**PREPARATION:**

- (a) Remove the engine ECU with connectors still connected.  
 (b) Disconnect the igniter connector.

**CHECK:**

Measure voltage between terminals IG1, 3, 5 (2, 4, 6) of the engine ECU connector and body ground when engine is cranked.

**OK:**

**Voltage: More than 0.1 V and less than 4.5 V**

**NG**

**Check and replace engine ECU (See page N-20).**

**OK**

**7** Check voltage between terminal 9 of igniter connector and body ground.

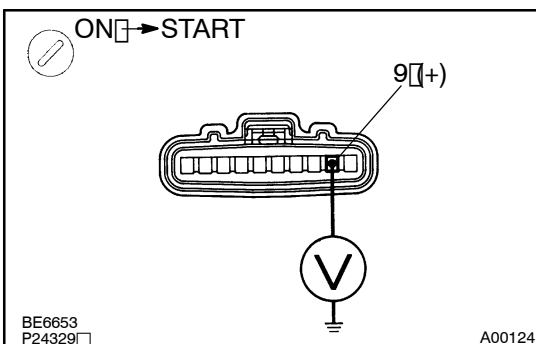
**PREPARATION:**

Disconnect the igniter connector.

**CHECK:**

Measure voltage between terminal 9 of igniter connector and body ground, when ignition switch is turned to "ON" and "START" position.

**OK:**

**Voltage: 9 - 14 V**

**OK**

**Repair igniter power source circuit.**

**NG**

**8** Check for open and short in harness and connector between ignition switch and igniter (See page IN-20).

NG

Repair or replace harness or connector.

OK

**9** Check EFI main relay (Marking: EFI) (See Pub. No. RM677E, page FI-45).

NG

Replace EFI main relay (marking: EFI).

OK

Replace igniter.