

DTC	B0101/14	Open in D Squib Circuit
------------	-----------------	--------------------------------

CIRCUIT DESCRIPTION

The D squib circuit consists of the airbag sensor assembly, spiral cable and steering wheel pad. It causes the airbag to deploy when the airbag deployment conditions are satisfied.

For details of the function of each component, see OPERATION on page RS-3.

DTC B0101/14 is recorded when an open is detected in the D squib circuit.

DTC No.	DTC Detecting Condition	Trouble Area
B0101/14	<ul style="list-style-type: none"> • Open circuit in D+ wire harness or D- wire harness of squib • D squib malfunction • Spiral cable malfunction • Airbag sensor assembly malfunction 	<ul style="list-style-type: none"> • Steering wheel pad (D squib) • Spiral cable • Airbag sensor assembly • Wire harness

WIRING DIAGRAM

See page DI-242.

INSPECTION PROCEDURE

1	Prepare for inspection. (See step 1 on page DI-368)
---	---

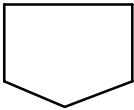

2	Check D squib circuit.
---	------------------------

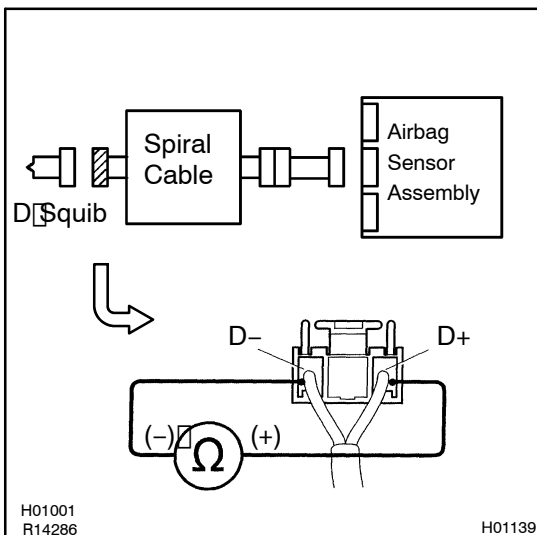

CHECK:

For the connector (on the spiral cable side) between the spiral cable and the steering wheel pad, measure the resistance between D+ and D-.

OK:

Resistance: Below 1 Ω

NG

Go to step 5.

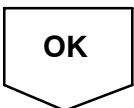

OK

3 Check airbag sensor assembly.

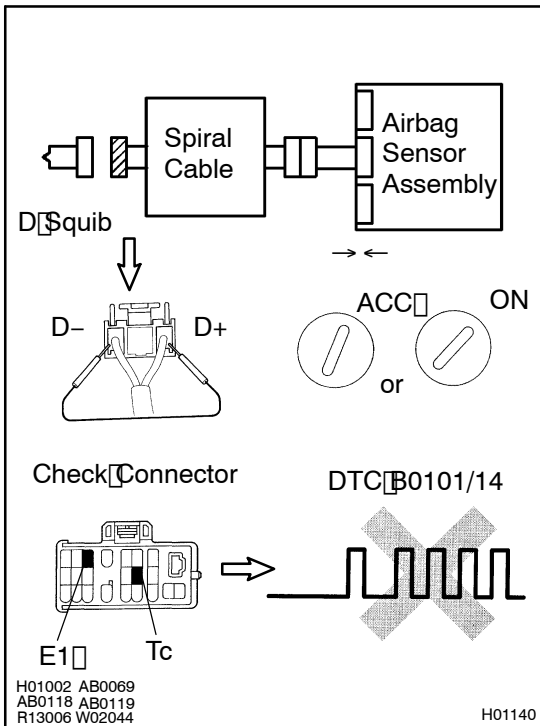

PREPARATION:

- Connect the connector to the airbag sensor assembly.
- Using a service wire, connect D+ and D- of the connector (on the spiral cable side) between the spiral cable and the steering wheel pad.
- Connect negative (-) terminal cable to the battery, and wait at least for 2 seconds.

CHECK:

- Turn ignition switch to ACC or ON, and wait at least for 20 seconds.
- Clear DTC stored in memory. (See page DI-229)
- Turn ignition switch to LOCK, and wait at least for 20 seconds.
- Turn ignition switch to ACC or ON, and wait at least for 20 seconds.
- Check DTC. (See page DI-229)

OK:

DTC B0101/14 is not output.

HINT:

Codes other than code B0101/14 may be output at this time, but they are not relevant to this check.

NG

Replace airbag sensor assembly.

OK

4 Check D Squib.

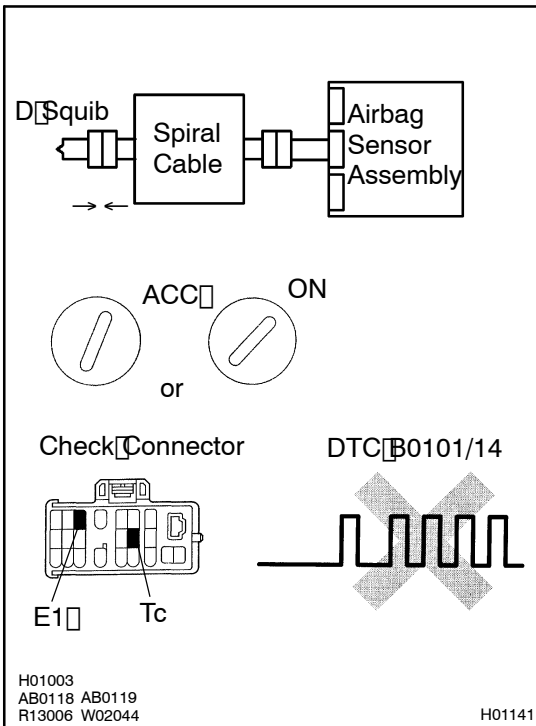

PREPARATION:

- Turn ignition switch to LOCK.
- Disconnect negative (-) terminal cable from the battery, and wait at least for 90 seconds.
- Connect the steering wheel pad connector.
- Connect negative (-) terminal cable to the battery, and wait at least for 2 seconds.

CHECK:

- Turn ignition switch to ACC or ON, and wait at least for 20 seconds.
- Clear DTC stored in memory. (See page DI-229)
- Turn ignition switch to LOCK, and wait at least for 20 seconds.
- Turn ignition switch to ACC or ON, and wait at least for 20 seconds.
- Check DTC. (See page DI-229)

OK:

DTC B0101/14 is not output.

HINT:

Codes other than code B0101/14 may be output at this time, but they are not relevant to this check.

NG

Replace steering wheel pad.

OK

From the results of the above inspection, the malfunctioning part can now be considered normal. To make sure of this, use the simulation method to check.

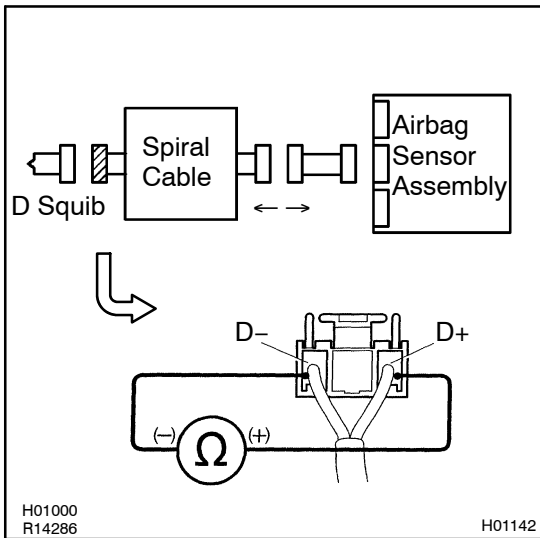
5 Check spiral cable.**PREPARATION:**

Disconnect the connector between the airbag sensor assembly and the spiral cable.

CHECK:

For the connector (on the spiral cable side) between the spiral cable and the steering wheel pad, measure the resistance between D+ and D-.

OK:

Resistance: Below 1 Ω

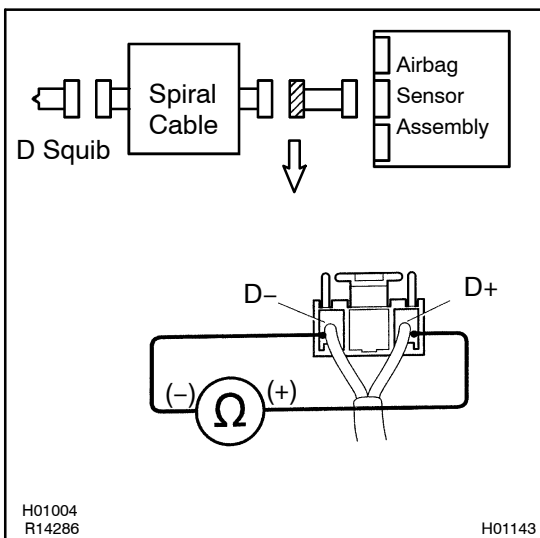
NG**Repair or replace spiral cable.****OK****6 Check harness between airbag sensor assembly and spiral cable.****CHECK:**

For the connector (on the spiral cable side) between the airbag sensor assembly and the spiral cable, measure the resistance between D+ and D-.

OK:

Resistance: Below 1 Ω

NG**Repair or replace harness or connector between airbag sensor assembly and spiral cable.****OK**

From the results of the above inspection, the malfunctioning part can now be considered normal. To make sure of this, use the simulation method to check.