

PRE-CHECK

1. DIAGNOSIS SYSTEM

- (a) As shown in the following illustration, each ECU of this vehicle is connected by communication bus and it transmits each signal by communication. This communication bus is self-diagnosed by Body ECU and it memorizes DTC when it detects communication stop to ECU or communication bus +B short or GND short. There is a possibility that Body ECU cannot self-diagnose accurately unless it doesn't work normal. So, please note that the troubleshooting of Body Electrical System should be done after confirming if Body ECU and Open door indicator works normal by 2 "BASIC INSPECTION" described later.

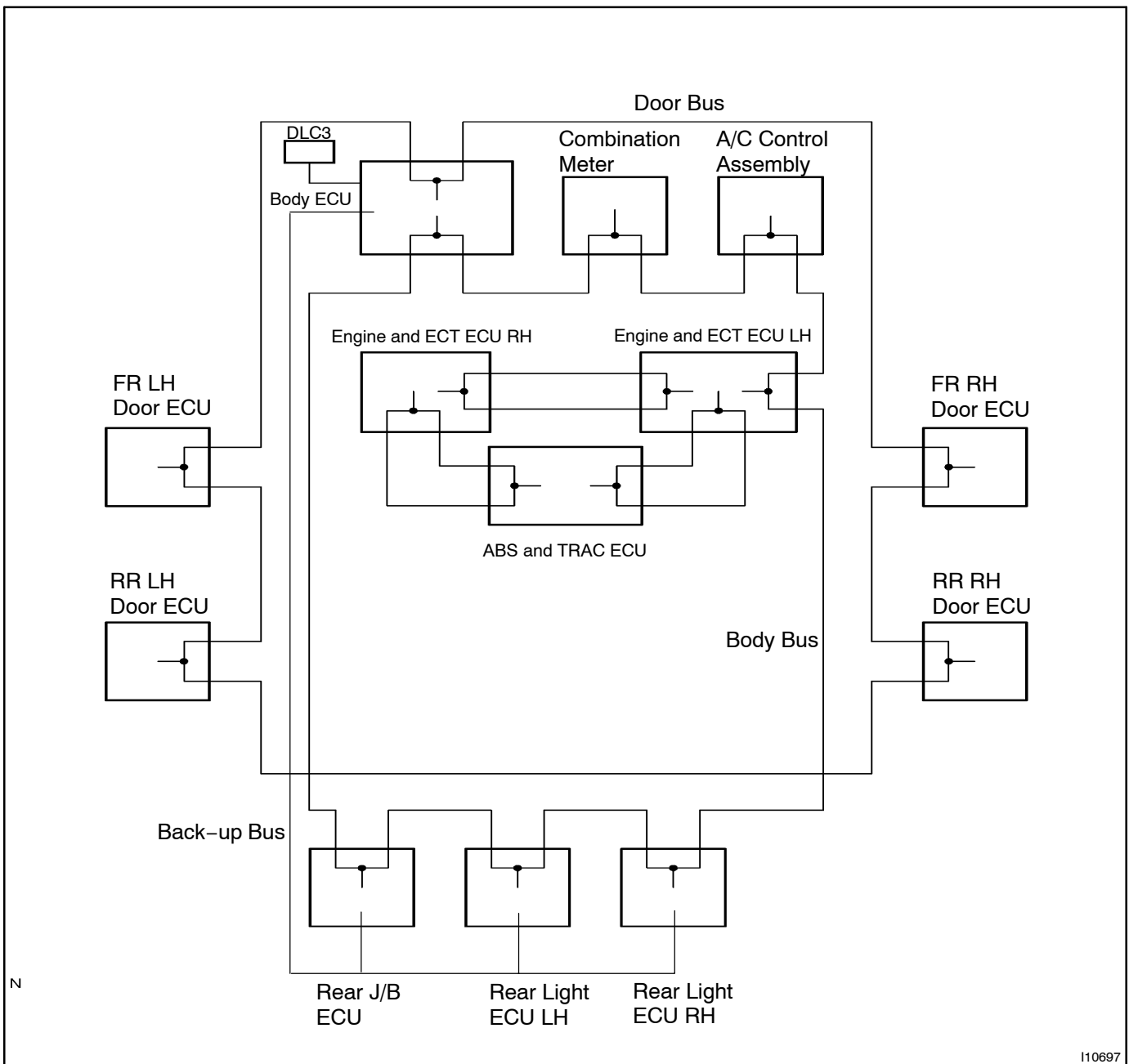

I10697

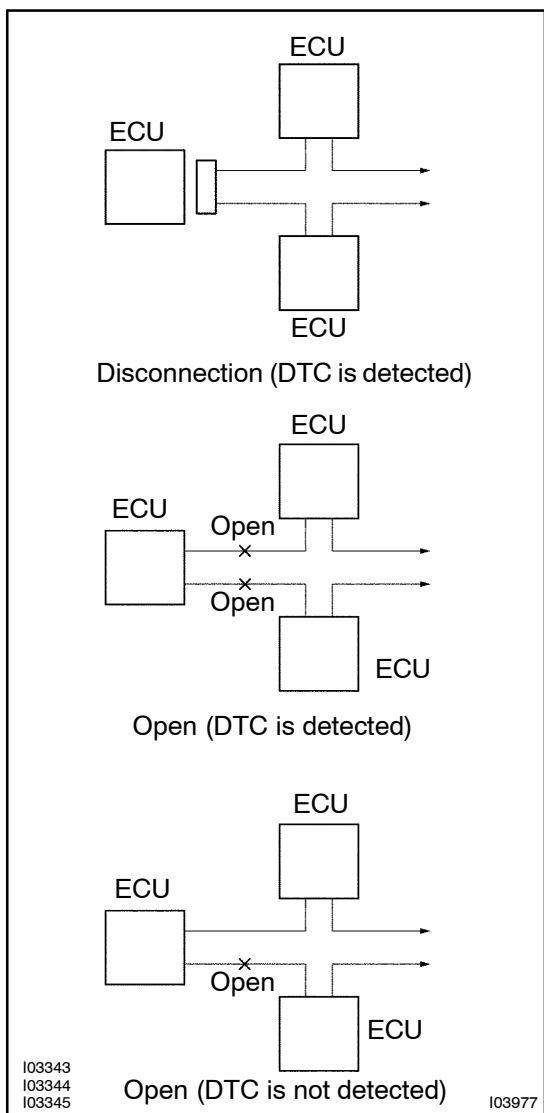

(b) If DTC of ECU communication stop is output, there is a possibility of connector disconnection or 2 communication buses open. It will not become abnormal with only 1 communication bus open.

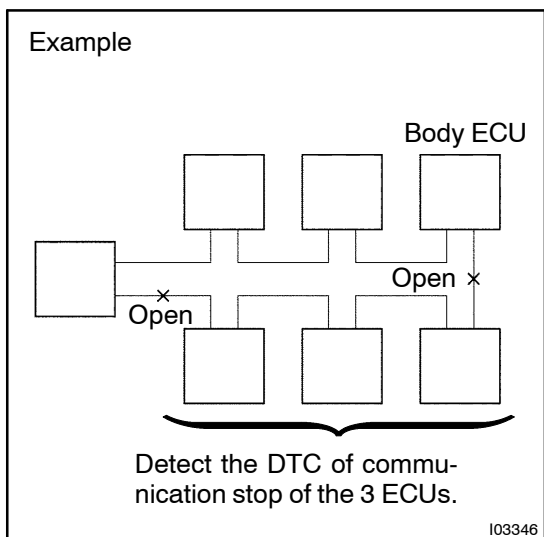

(c) If 2 communication buses are open at the position as shown in the illustration, DTC of ECU communication stop between those 2 buses is output.

2. BASIC INSPECTION

INSPECT BODY ECU

1 Check Body ECU operation.

HINT:

With this inspection Body ECU CPU can be diagnosed if it works normal or not.

CHECK:

Check if the luggage compartment door opener works normal.

OK

Go to next step "OPEN DOOR INDICATOR LIGHT INSPECTION".

NG

2 Check luggage compartment door opener system (Except Body ECU).
(See page BE-2).

OK

Replace the Body ECU.

NG

Repair or replace malfunction part.

INSPECT OPEN DOOR INDICATOR LIGHT.

1 Check open door indicator light.

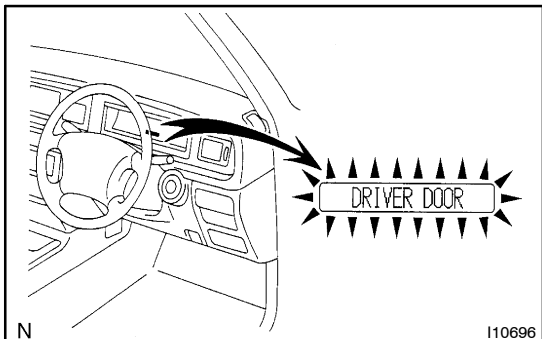
**CHECK:**

Check if open door indicator light is turned on when either door open.

HINT:

If open door indicator light is not turned on, DTC will not be output.

OK

Go to step 3. "DTC CHECK".

NG

Repair the open door indicator light.
(See page BE-61)

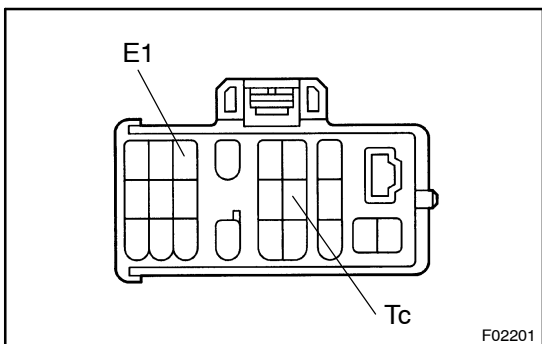
**3. DTC CHECK (Using diagnosis check wire)**

- (a) Using SST, connect terminals Tc and E1 of DLC1.
SST 09843-18020
- (b) Turn the ignition switch ON.
- (c) Read the DTC on the open door indicator light.

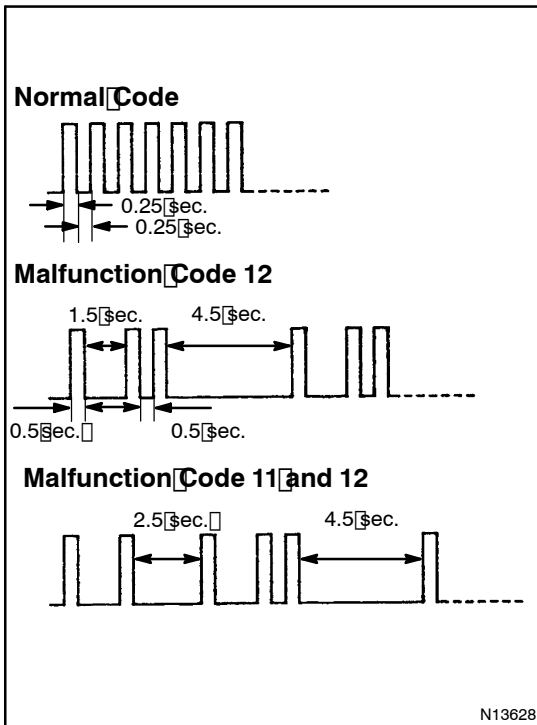

As an example, the blinking patterns for codes: normal, 12, and 11 and 12 are shown in the illustration.

- (d) Check for the problem using the DTC table on the next page.
- (e) After completing the check, turn the ignition switch off, and disconnect terminals Tc and E1.

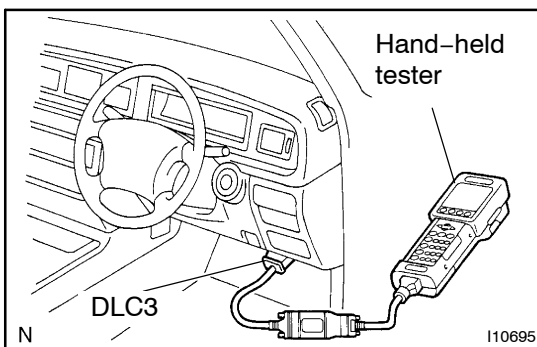

4. DTC CHECK (Using hand-held tester)

- (a) Prepare the hand-held tester.
- (b) Connect the hand-held tester to DLC3.
- (c) Turn the ignition switch ON and switch the hand-held tester main switch ON.
- (d) Use the hand-held tester to check the DTCs, note them down. (For opening instructions, see the hand-held tester's instruction book.)
- (e) See page DI-713 to confirm the details of the DTCs.

5. DTC CLEARANCE

DTC will be cleared when the trouble output to DTC is recovered normally.