

## Jam protection limit switch circuit

### CIRCUIT DESCRIPTION

Jam protection limit switch is built-in the power window motor. This switch functions to turn "OFF" before the top dead center, and ECU reads this "OFF" signal resulting in closing the window fully.

### WIRING DIAGRAM

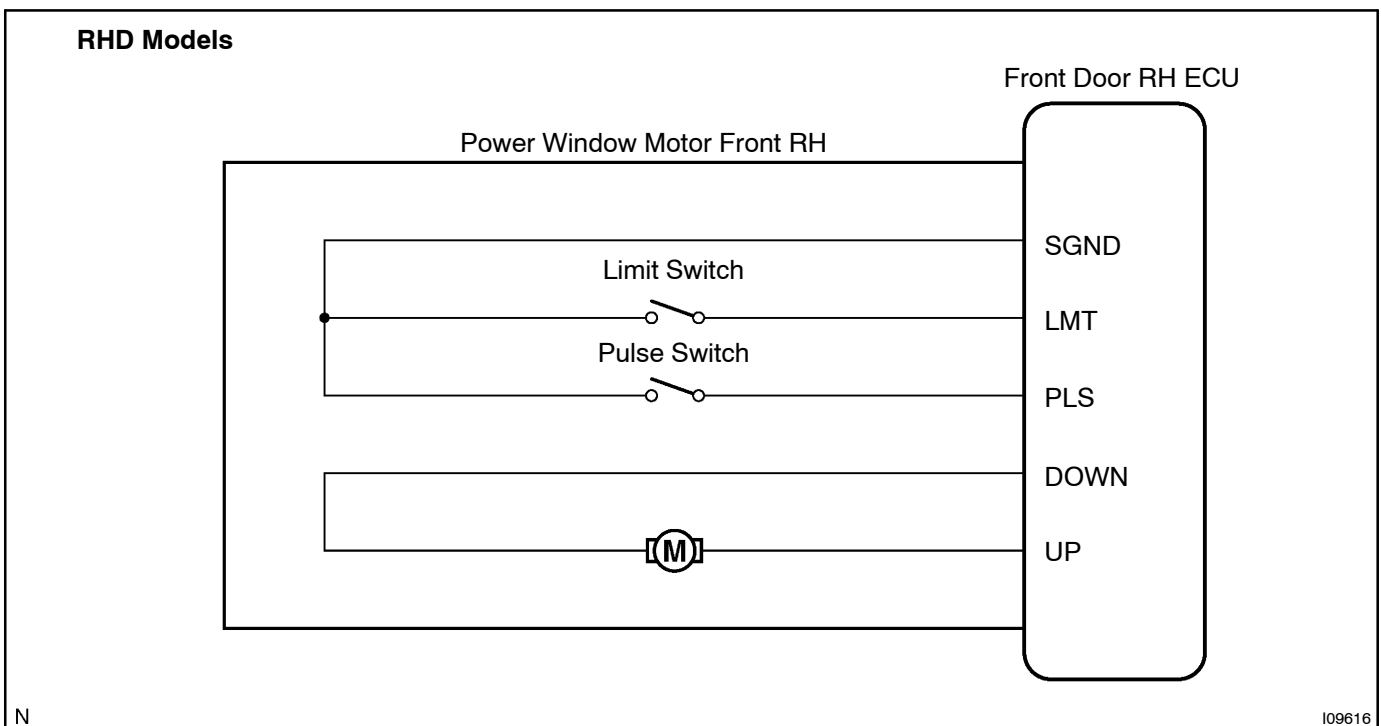
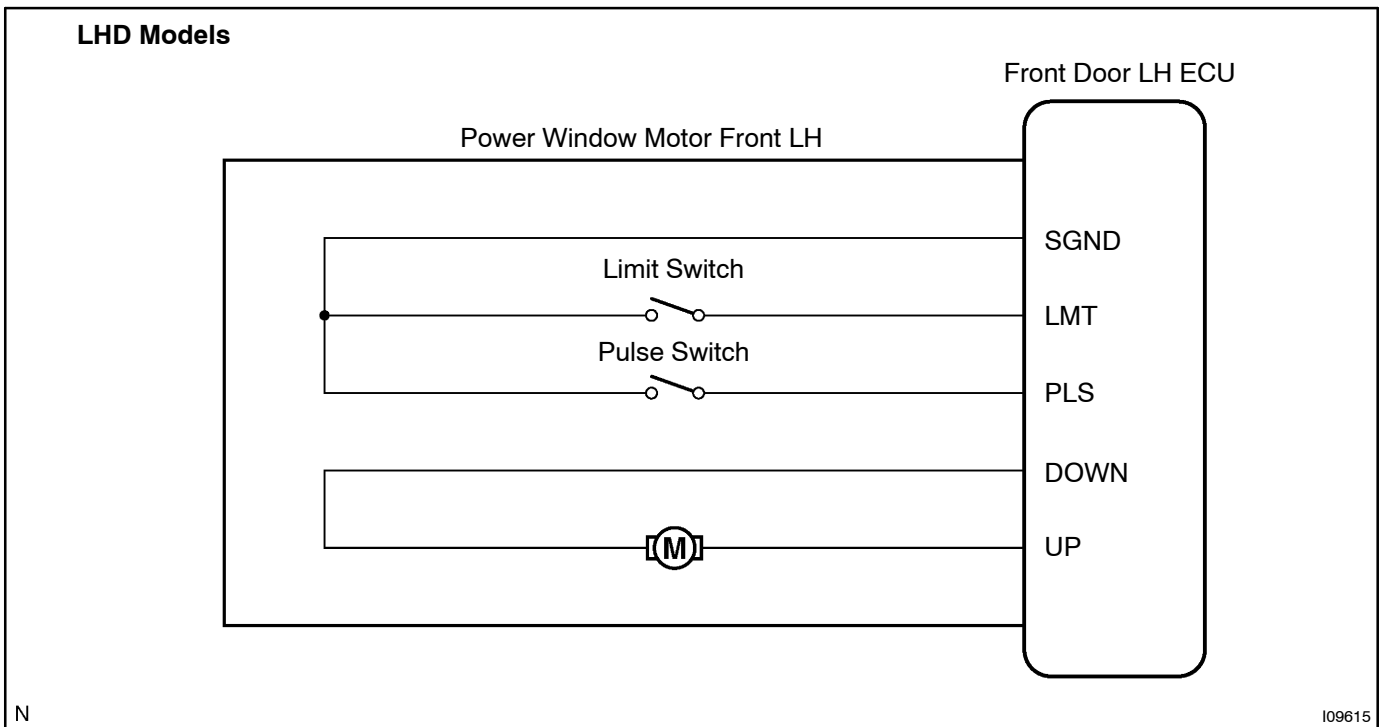

**INSPECTION PROCEDURE**

1 Check jam protection limit switch (See page BE-87).

NG

Replace the power window motor.

OK

2 Check wireharness and connector between jam protection limit switch and driver door ECU (See page N-30).

NG

Repair or replace wireharness or connector.

OK

Proceed to next circuit inspection shown on problem symptoms table (See page DI-554).