

INSPECTION

1. CHECK DISC, PLATE AND FLANGE

Check to see if the sliding surface of the disc, plate and flange are worn or burnt.

If necessary, replace them.

HINT:

- If the lining of the disc is peeling off or discolored, or even if a part of the printed numbers is defaced, replace all discs.
- Before assembling new discs, soak them in ATF for at least 15 minutes.

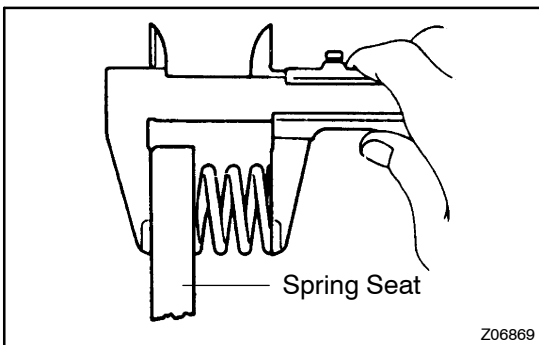

2. CHECK PISTON RETURN SPRING

Using vernier calipers, measure the free length of the spring together with the spring seat.

Standard free length: 12.9 mm (0.508 in.)