

REPLACEMENT

NOTICE:

When using a vise, do not overtighten it.

1. IF NECESSARY, REPLACE BEARING AND OIL SEAL

- (a) Using SST, remove the bearing and oil seal from the rack housing.

SST 09612-30012

NOTICE:

Be careful not to damage the rack housing.

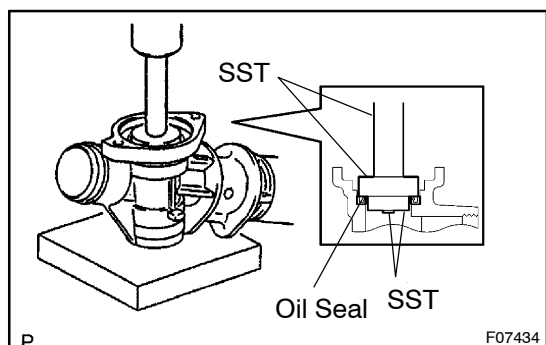

- (b) Coat a new oil seal lip with power steering fluid.

- (c) Using SST, press in the oil seal.

SST 09950-60010 (09951-00280, 09951-00400, 09952-06010), 09950-70010 (09951-07100)

NOTICE:

Make sure that the oil seal is installed facing in the correct direction.

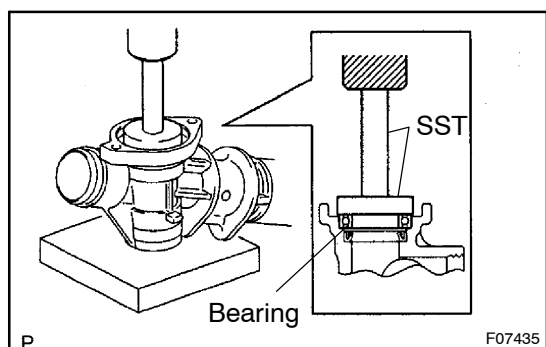

- (d) Using SST, press in a new bearing.

SST 09950-60010 (09951-00460), 09950-70010 (09951-07100)

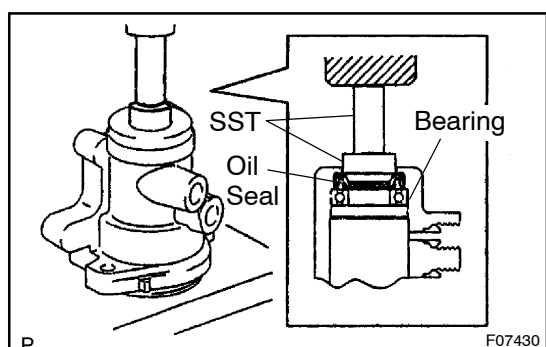

2. IF NECESSARY, REPLACE BEARING AND OIL SEAL

- (a) Using SST, press out the oil seal and bearing from the control valve housing.

SST 09950-60010 (09951-00240), 09950-70010 (09951-07100)

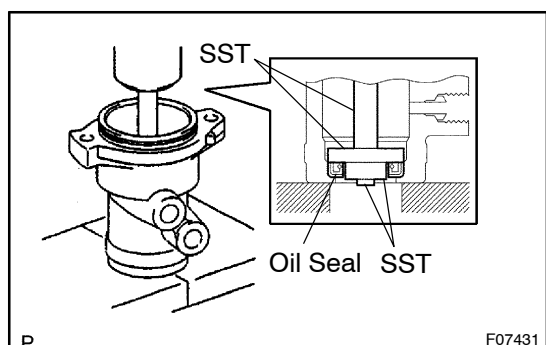

- (b) Coat a new oil seal lip with power steering fluid.

- (c) Using SST, press in the oil seal.

SST 09950-60010 (09951-00180, 09951-00310, 09952-06010), 09950-70010 (09951-07150)

NOTICE:

Make sure that the oil seal is installed facing in the correct direction.

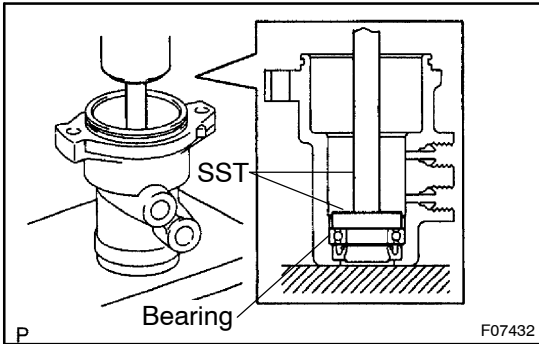

- (d) Using SST, press in a new bearing.
 SST 09950-60010 (09951-00340),
 09950-70010 (09951-07150)

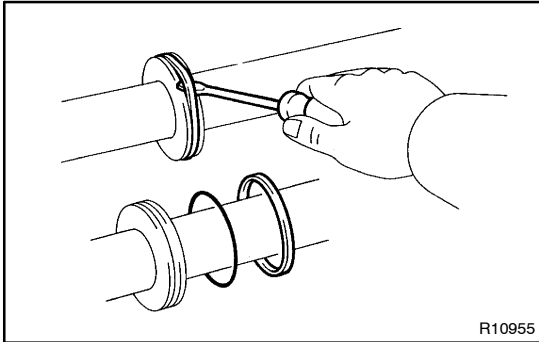

3. IF NECESSARY, REPLACE TEFLON RING AND O-RING

- (a) Using a screwdriver, remove the teflon ring and O-ring from the steering rack.

NOTICE:

Be careful not to damage the groove for the ring.

- (b) Coat a new O-ring with power steering fluid and install it to the steering rack.

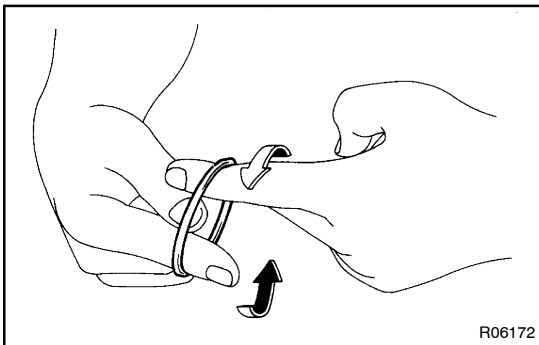

- (c) Expand a new teflon ring with your fingers.

NOTICE:

Be careful not to overexpand the teflon ring.

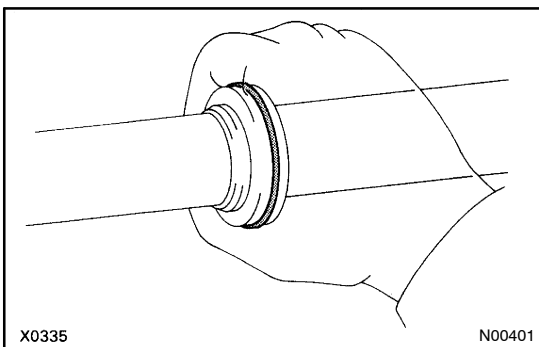

- (d) Coat the teflon ring with power steering fluid.
 (e) Install the teflon ring to the steering rack and settle it down with your fingers.

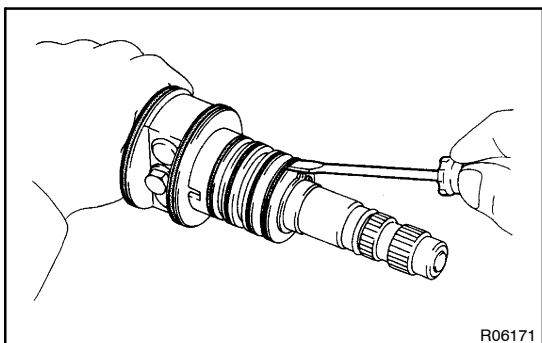

4. IF NECESSARY, REPLACE TEFLON RINGS

- (a) Using a screwdriver, remove the 4 teflon rings from the control valve assembly.

NOTICE:

Be careful not to damage the grooves for the ring.

- (b) Expand 4 new teflon rings with your fingers.

NOTICE:

Be careful not to overexpand the teflon rings.

- (c) Coat the teflon rings with power steering fluid.
 (d) Install the teflon rings to the control valve assembly, and settle them down with your fingers.

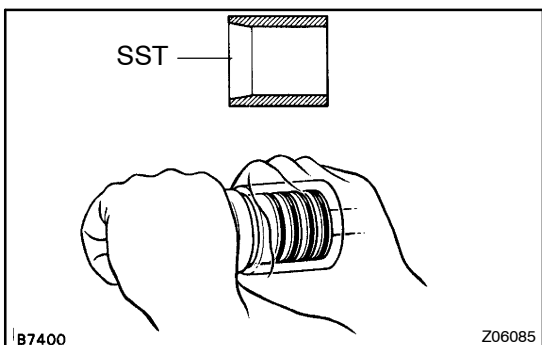

- (e) Carefully slide the tapered end of SST over the teflon rings until they fit to the control valve assembly.

SST 09631-20081

NOTICE:

Be careful not to damage the teflon rings.

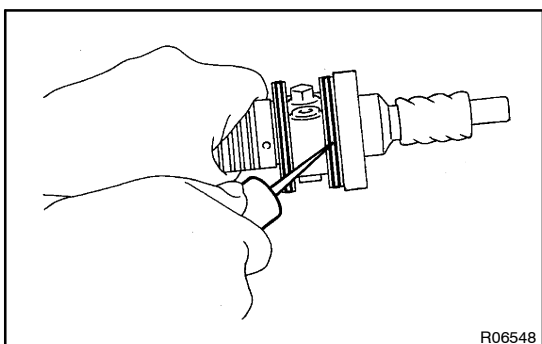

5. IF NECESSARY, REPLACE TEFLON RINGS AND O-RINGS

- (a) Using a screwdriver, remove the 2 teflon rings and O-rings from the control valve assembly.

NOTICE:

Be careful not to damage the grooves for the ring.

- (b) Coat 2 new O-rings with power steering fluid and install them to the control valve assembly.

- (c) Expand 2 new teflon rings with your fingers.

NOTICE:

Be careful not to overexpand the teflon rings.

- (d) Coat the teflon rings with power steering fluid.
 (e) Install the teflon rings to the control valve assembly, and settle them down with your fingers.

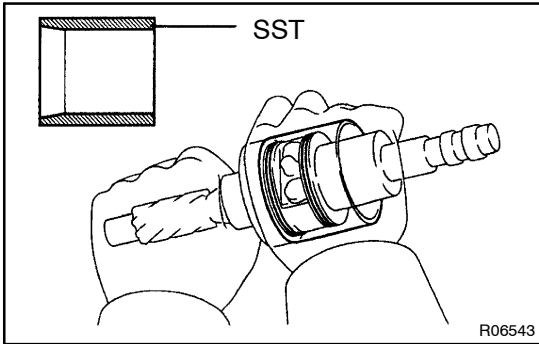

- (f) Carefully slide the tapered end of SST over the rings until they fit to the control valve assembly.

SST 09631-32020

NOTICE:

Be careful not to damage the rings.

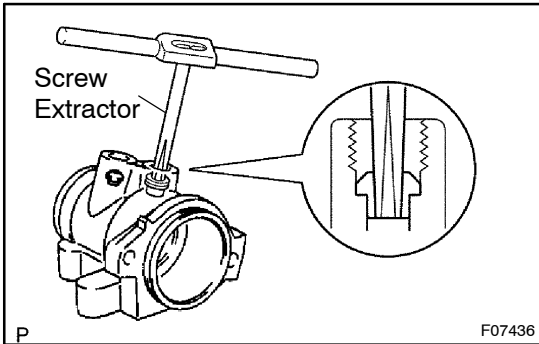

6. IF NECESSARY, REPLACE UNION SEAT

- (a) Using a screw extractor, remove the union seat from the control valve housing.

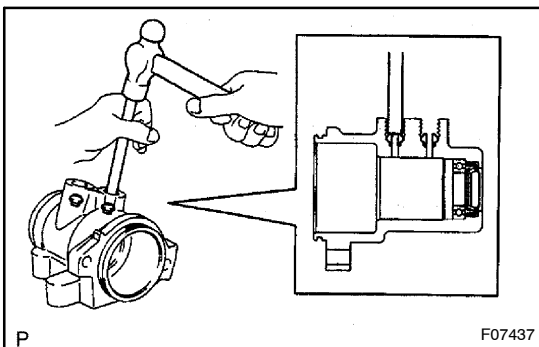

- (b) Using a plastic hammer and sliding handle, lightly tap in a new union seat.

NOTICE:

Before installing the union seat, remove dust sticking to the control valve housing.

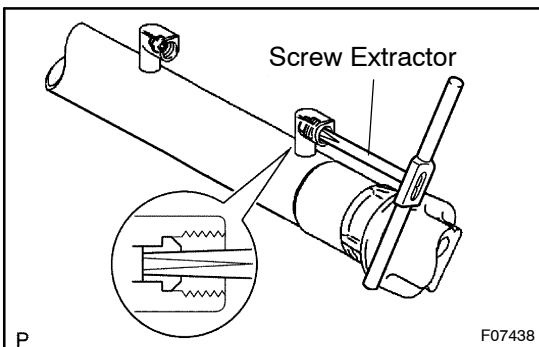

7. IF NECESSARY, REPLACE UNION SEAT

- (a) Using a screw extractor, remove the union seat from the rack housing.

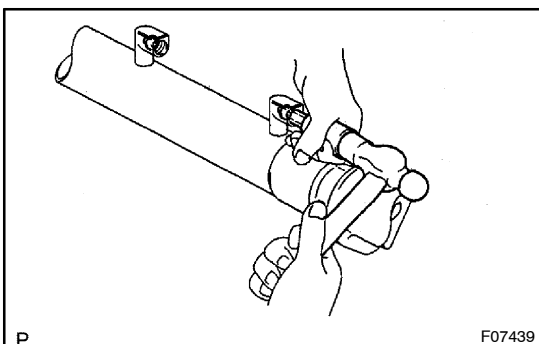

- (b) Using a socket hexagon wrench (8 mm) and a hammer, lightly tap in a new union seat.

NOTICE:

Before installing the union seat, remove the dust sticking to the rack housing.