

LOCATION

LHD:

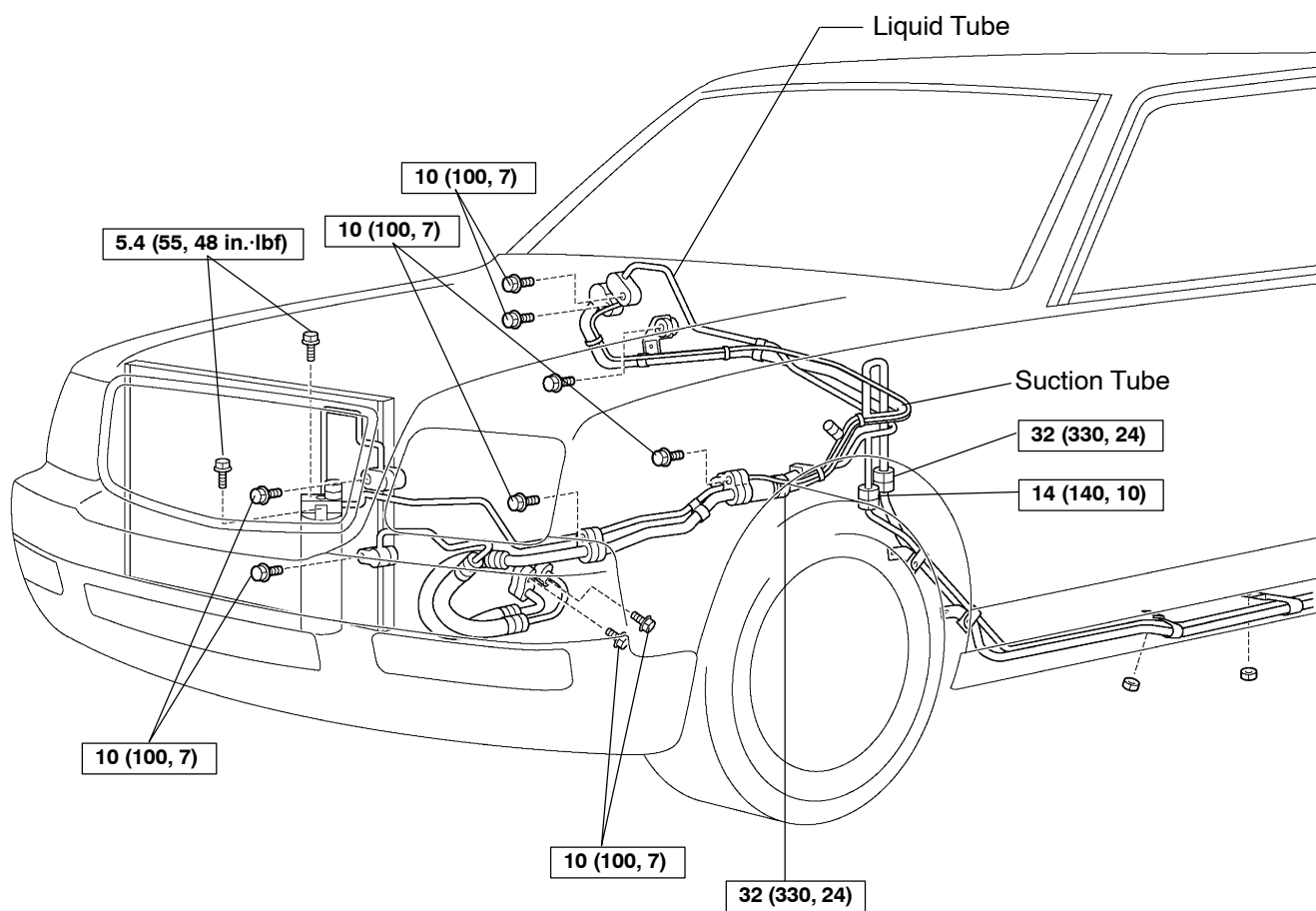

N·m (kgf·cm, ft·lbf) : Specified torque:

Rear:

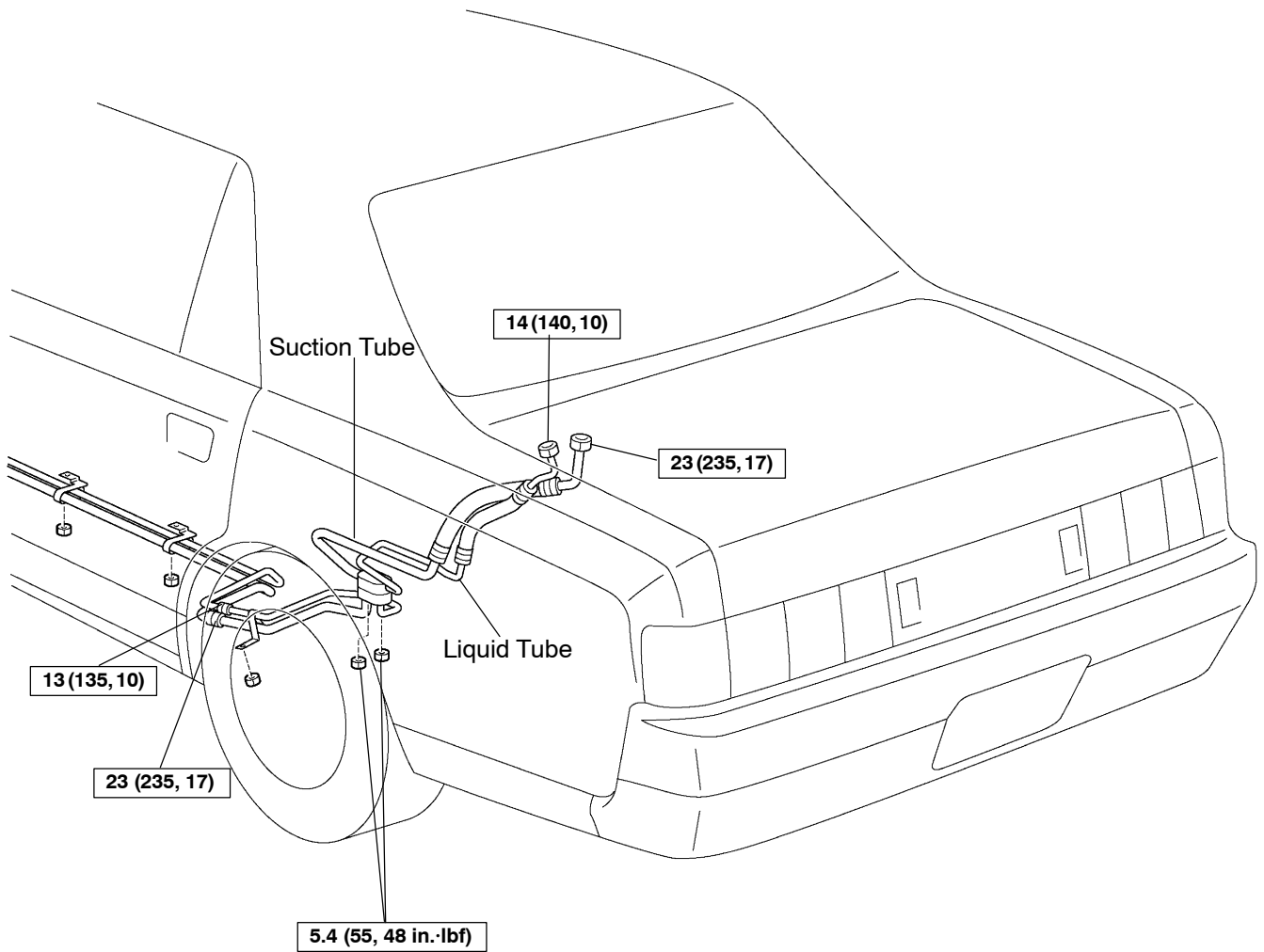

N·m (kgf·cm, ft·lbf) : Specified torque: