

PWS circuit

CIRCUIT DESCRIPTION

This circuit is the power source of the master switch for the driver's door and the door lock switch for the passenger's doors.

WIRING DIAGRAM

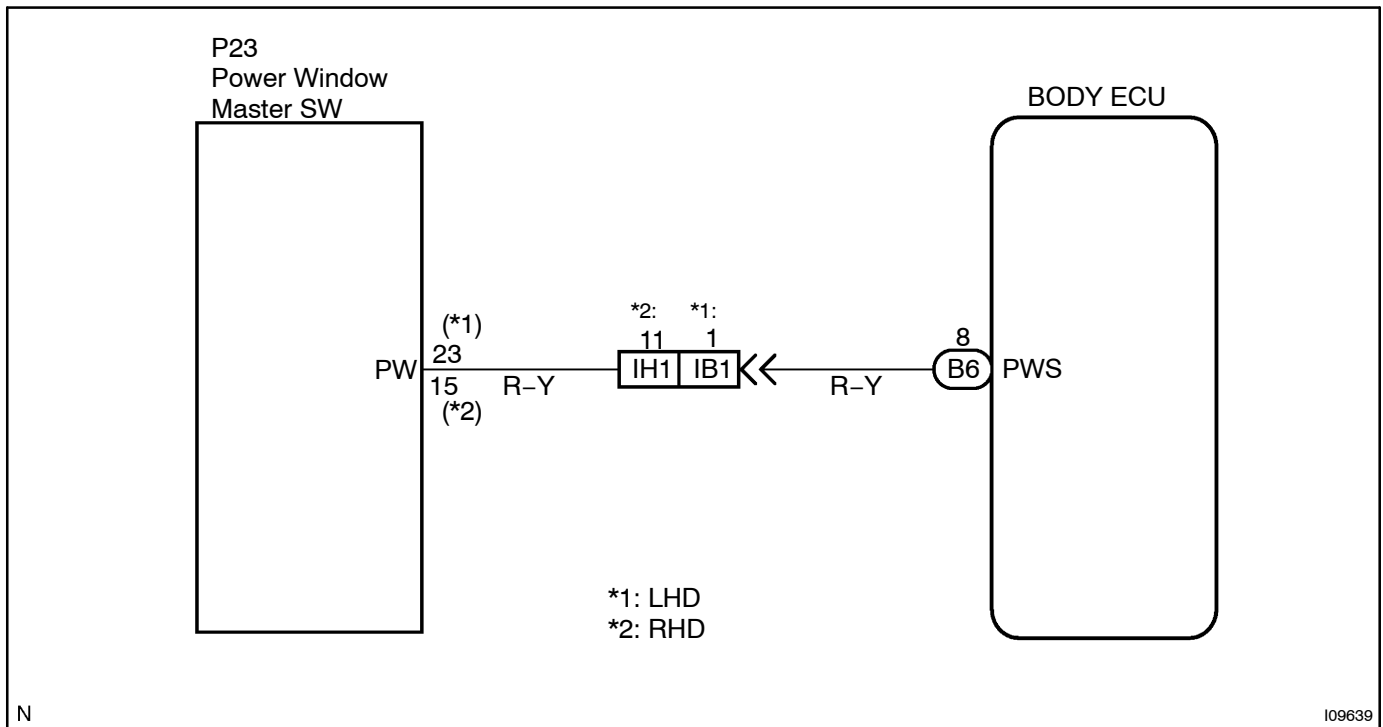

INSPECTION PROCEDURE

1 Check wireharness and connector between master switch and Body ECU, door lock switch of passenger door and Body ECU (See page N-30).

NG

Repair or replace wireharness or connector.

OK

Proceed to next circuit inspection shown on problem symptoms table (See page DI-488).