

PRE-CHECK

1. DIAGNOSIS SYSTEM

(a) Description

HINT:

This engine has 2 ECU for LH and RH bank respectively. DTC is stored in the memory of each ECU of respective banks.

- When troubleshooting Multiplex OBD (M-OBD) vehicles, the only difference from the usual troubleshooting procedure is that you connect to the vehicle the hand-held tester, and read off various data output from the vehicle's engine ECU.
- The vehicle's on-board computer indicates the EFI on the multi-information display on the instrument panel when the computer detects a malfunction in the computer itself or in drive system components. In addition to an indication of the EFI when a malfunction is detected, the applicable Diagnostic Trouble Codes (DTC) recorded in the engine ECU memory (See page DI-16). When the malfunction does not reoccur, the EFI is indicated until the ignition switch is turned off, and then the EFI is not indicated when the ignition switch is turned on but the DTCs remain recorded in the engine ECU memory.

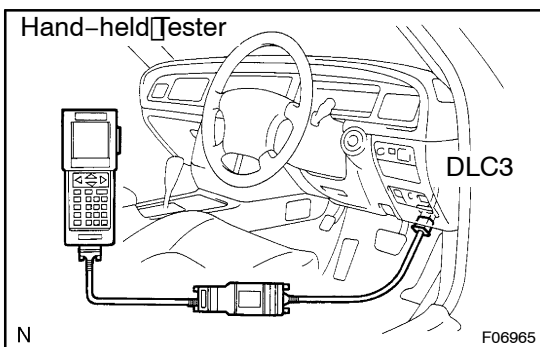

- To check the DTCs, connect the hand-held tester to Data Link Connector 3 (DLC3) on the vehicle or read the diagnostic trouble code which is indicated on the multi information display when TC and CG terminals on the DLC3 or Tc and E1 terminals on the check connector are connected. The hand-held tester also enables you to erase the DTCs and check freeze frame data and various forms of engine data. (For operating instructions, see the instruction book.)

- The diagnosis system operates in normal mode during normal vehicle use. It also has a check (test) mode for technicians to simulate malfunction symptoms and troubleshoot. Most DTCs use 2 trip detection logic* to prevent erroneous detection, and ensure thorough malfunction detection. By switching the engine ECU to check (test) mode using hand-held tester when troubleshooting, the technician can cause the EFI on the multi-information display for a malfunction that is only detected once or momentarily. (Hand-held tester only) (See step 2)
- *2 trip detection logic: When a logic malfunction is first detected, the malfunction is temporarily stored in the engine ECU memory. If the same malfunction is detected again during the second drive test, this second detection causes the EFI on the multi-information display to indicate. The 2 trip repeats the same mode a 2nd time. (However, the IG switch must be turned OFF between the 1st trip and 2nd trip.)
- Freeze frame data:
Freeze frame data records the engine condition when a malfunction is detected.
Because freeze frame data records the engine conditions (fuel system, calculator load, Water temperature, fuel trim, engine speed, vehicle speed, etc.) when the malfunction is detected, when troubleshooting it is useful for determining whether the vehicle was running or stopped, the engine warmed up or not, the air-fuel ratio lean or rich, etc. at the time of the malfunction.

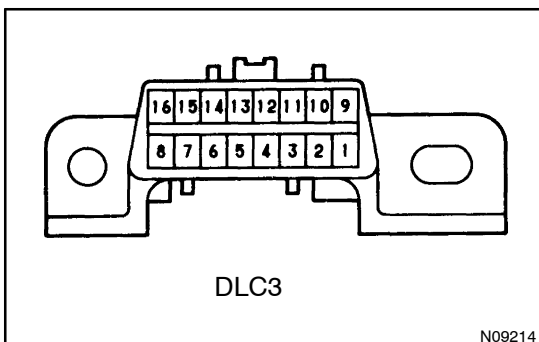

(b) Check the DLC3.

The vehicle's engine ECU uses ISO 14230 for communication. The terminal arrangement of DLC3 complies with ISO 15031-3 and matches the ISO 14230 format.

Terminal No.	Connection (Voltage or Resistance)	Condition
7	Bus (+) Line (Pulse generation)	During transmission
4	Chassis Ground (-) → Body Ground (1 Ω or less)	Always
16	Battery Positive (-) → Body Ground (9 - 14 V)	Always

HINT:

If your display shows "UNABLE TO CONNECT TO VEHICLE" when you have connected the cable of the hand-held tester to DLC3, turned the ignition switch ON and operated the hand-held tester, there is a problem on the vehicle side or tool side.

- If communication is normal when the tool is connected to another vehicle, inspect DLC3 on the original vehicle.
- If communication is still not possible when the tool is connected to another vehicle, the problem is probably in the tool itself, so consult the Service Department listed in the tool's instruction manual.

2. INSPECT DIAGNOSIS (Normal Mode)

(a) Check the DTC using hand-held tester.

NOTICE:

Hand-held tester only: When the diagnosis system is switched from normal mode to check mode, it erases all DTCs and frozen frame data recorded in normal mode. So before switching modes, always check the DTCs and frozen frame data, and note them down.

- (1) Prepare the hand-held tester.
- (2) Connect the hand-held tester to DLC3.
- (3) Turn the ignition switch ON and push the hand-held tester main switch ON.
- (4) Use the hand-held tester to check the DTCs and frozen frame data, note them down. (For operating instructions, see the hand-held tester instruction book.)
- (5) See page DI-16 to confirm the details of the DTCs.

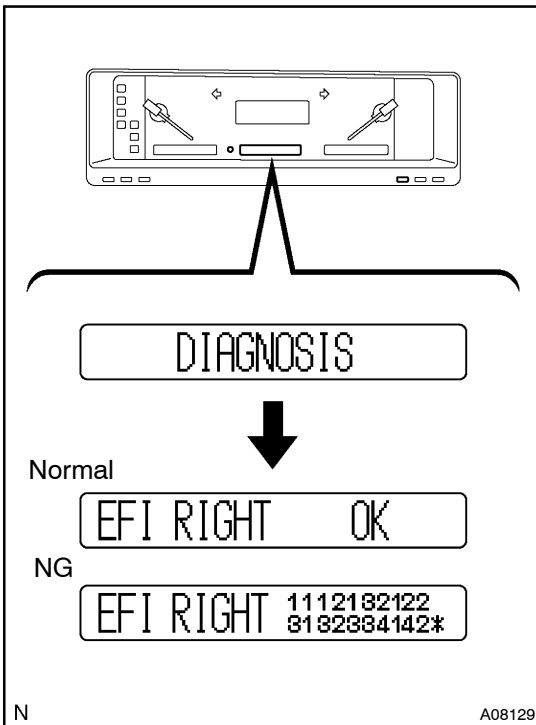

- (b) Check the DTC when not using hand-held tester.
- (1) Using SST, connect between terminals 13 (TC) and 4 (CG) of DLC3.
- SST 09843 - 18040
- (2) Turn ignition switch ON.

HINT:

At this time, "DIAGNOSIS" is displayed on the multi-information display.

- (3) Push the SCROLL switch and "EFI RIGHT" will be displayed in the multi-information display, and after about 3 sec., the DTCs will be displayed.
- (4) Read the diagnostic trouble code on the multi-information display.

HINT:

- If a diagnostic trouble code is not indicated, check the MPX circuit (See page DI-20).
 - The multi-information display can accommodate up to 10 codes at a time. If more than 10 codes are input, an asterisk (*, representing display overflow mark) follows the 10th code. Codes bigger than 11 will not be displayed.
- (5) Push the SCROLL switch and check the DTC of the "EFI LEFT" in the same way.
 - (6) See page DI-16 to confirm the details of the DTCs.

NOTICE:

When simulating symptoms with out a hand-held tester to check the DTCs, use normal mode. For code on the DTC chart subject to "2 trip detection logic", turn the ignition switch OFF after the symptom is simulated the first time. Then repeat the simulation process again. When the problem has been simulated twice, the EFI is indicated on the multi-information display and the DTCs are recorded in the engine ECU.

- (c) Check the DTC for ETCS
- (1) Using SST, connect between terminals 13 (TC) and 4 (CG) of DLC3.
- SST 09843-18040
- (2) Turn ignition switch ON.

HINT:

At this time, "DIAGNOSIS" is displayed on the multi-information display.

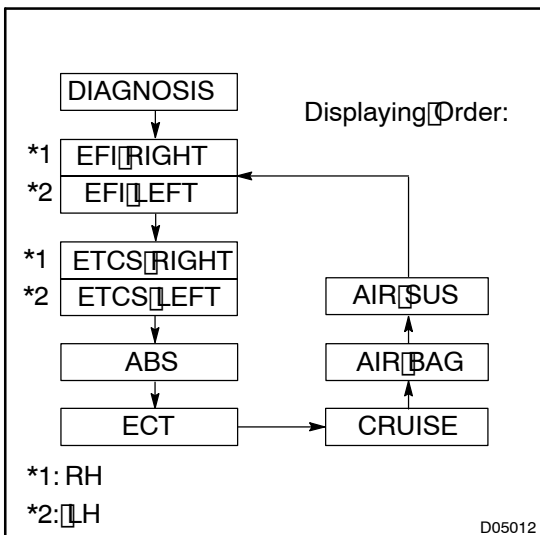

- (3) Push the SCROLL switch to change the multi-information display to "ETCS RIGHT". The DTCs will be displayed about 3 sec. after.
- (4) Read the diagnostic trouble code on the multi-information display.
- (5) Check the "ETCS LEFT" in the same way.

HINT:

If a diagnostic trouble code is not output, check the MPX circuit (See page DI-20).

- (6) Check details of the malfunction using the DTC chart on page DI-16.
 - (7) After completing the check, disconnect terminals 13(TC) and 4(CG) and turn off the display.
- (d) Clear the DTC.
The DTCs and frozen frame data will be erased by either actions.
- (1) Operating the hand-held tester to erase the codes. (See the hand-held tester's instruction book for operating instructions.)
 - (2) Disconnecting the battery terminals of EFI and ECTS fuses.

NOTICE:

If the hand-held tester switches the engine ECU from normal mode to check mode or vice-versa, or if the ignition switch is turned from ON to ACC or OFF during check mode, the DTCs and frozen frame data will be erased.

3. INSPECT DIAGNOSIS (Check Mode)

Hand-held tester only:

Compared to the normal mode, the check mode has an increased sensitivity to detect malfunctions.

Furthermore, the same diagnostic items which are detected in the normal mode can also be detected in the check (test) mode.

- (a) Check the DTC.
 - (1) Initial conditions
 - Battery positive voltage 11V or more.
 - Throttle valve fully closed.
 - Transmission in "P" or "N" position.
 - Air conditioning switched OFF.
 - (2) Turn the ignition switch OFF.
 - (3) Prepare the hand-held tester.
 - (4) Connect the hand-held tester to the DLC3.
 - (5) Turn the ignition switch ON and push the hand-held tester main switch ON.
 - (6) Switch the hand-held tester normal mode to check (test) mode.

NOTICE:

If the hand-held tester switches the engine ECU from normal mode to check mode or vice-versa, or if the ignition switch is turned from ON to ACC or OFF during check mode, the DTCs and frozen frame data will be erased.

- (7) Start the engine.
- (8) Simulate the conditions of the malfunction described by the customer.

NOTICE:

Leave the ignition switch ON until you have checked the DTCs, etc.

- (9) After simulating the malfunction conditions, use the hand-held tester diagnosis selector to check the DTCs and frozen frame data, etc.

HINT:

Take care not to turn the ignition switch OFF. Turning the ignition switch OFF switches the diagnosis system from check (test) mode to normal mode. so all DTCs, etc. are erased.

- (10) After checking the DTC, inspect the applicable circuit.

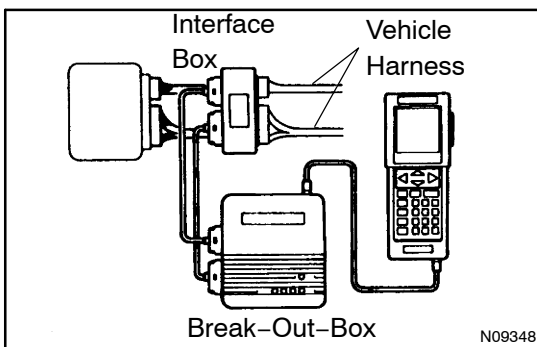

- (b) Engine ECU Terminal Values Measurement Using Break-Out-Box and Hand-Held Tester

- (1) Hook up the break-out-box and hand-held tester to the vehicle.
- (2) Read the engine ECU input/output values by following the prompts on the tester screen.

HINT:

- Hand-held tester has a "Snapshot" function. This records the measured values and is effective in the diagnosis of intermittent problems.
- Please refer to the hand-held tester/break-out-box operator's manual for further details.

4. FAIL-SAFE CHART

If any of the following codes is recorded, the engine ECU enters fail-safe mode.

DTC No.	Fail-Safe Operation	Fail-Safe Deactivation Conditions
P0110/24	Intake air temp. is fixed at 20°C (68°F)	Returned to normal condition
P0115/22	Water temp. is fixed at 80° (176°F)	Returned to normal condition
P0120/41	VTA is fixed at 0°	The following condition must be repeated at least 2 times consengine ECUtively When closed throttle position switch is ON: 0.1 V ≤ VTA and 0.95 V
P0325/52	Max. timing retardation	IG switch OFF
P0500/42	High RPM for cut is prohibited ISC control prohibited	Returned to normal condition
P1300/14	Fuel cut	Returned to normal condition

5. CHECK FOR INTERMITTENT PROBLEMS

HAND-HELD TESTER only:

By putting the vehicle's engine ECU in check (test) mode, 1 trip detection logic is possible instead of 2 trip detection logic and sensitivity to detect open circuits is increased. This makes it easier to detect intermittent problems.

- (1) Clear the DTC (See step 3).
- (2) Set the check (test) mode (See step 3).
- (3) Perform a simulation test (See page N-10).
- (4) Check the connector and terminal (See page N-20).
- (5) Check the visual check and contact pressure (See page N-20).
- (6) Handle the connector (See page N-20).

6. BASIC INSPECTION

When the malfunction code is not confirmed in the DTC check, troubleshooting should be carried out in the order for all possible circuits to be considered as the causes of the problems. In many cases, by carrying out the basic engine check shown in the following flow chart, the location causing the problem can be found quickly and efficiently. Therefore, use of this check is essential in engine troubleshooting.

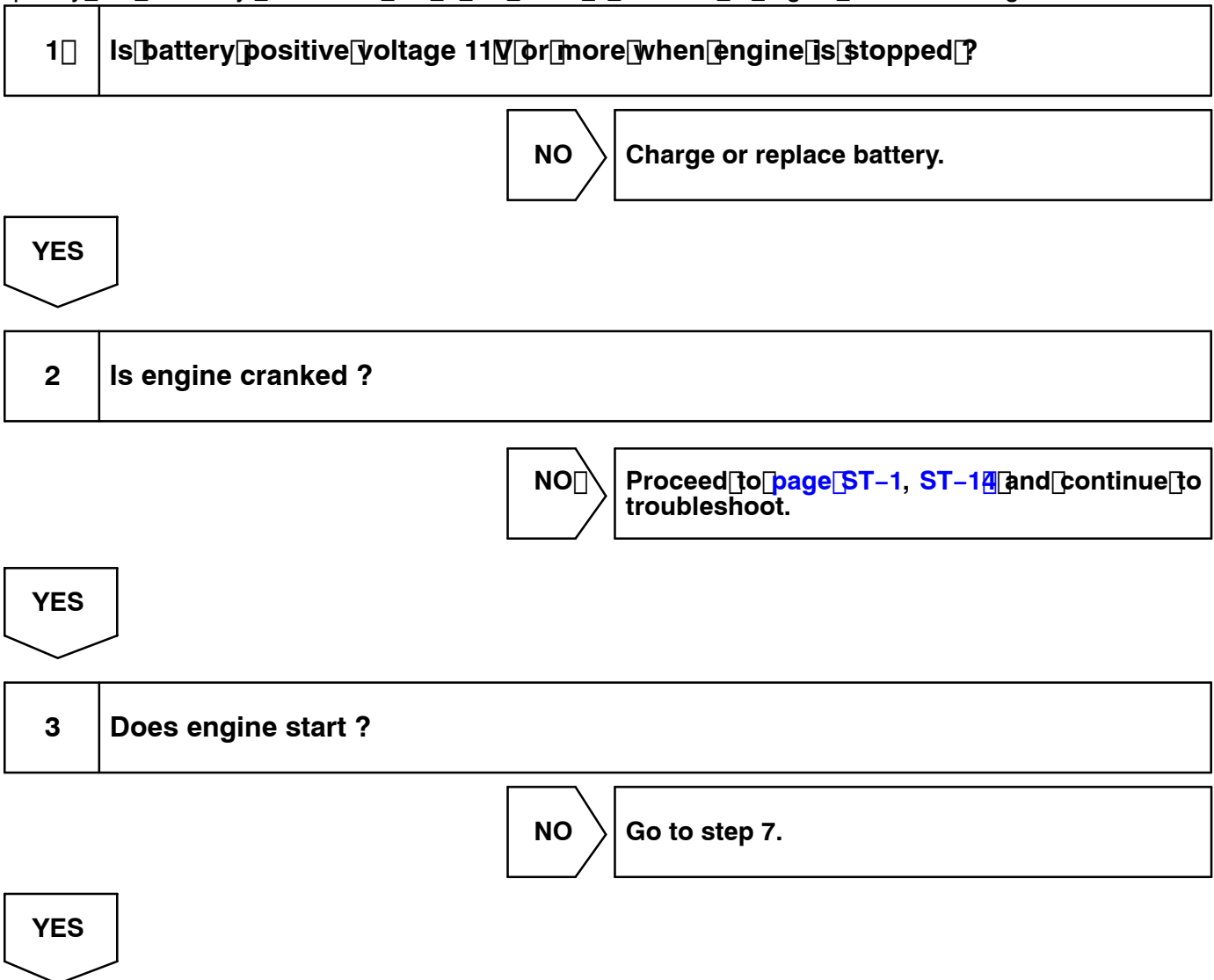

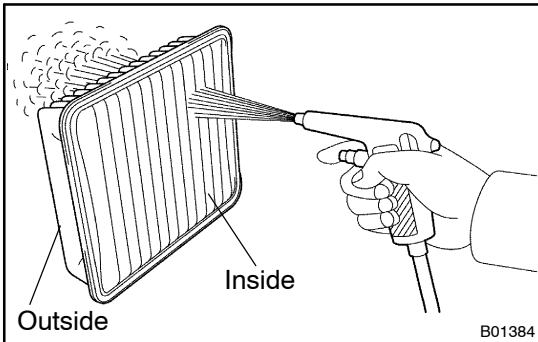
4 Check air filter.**PREPARATION:**

Remove the air filter.

CHECK:

Visually check that the air filter is not excessively dirty or oily.

HINT:

If necessary, clean the filter with compressed air. First blow from inside thoroughly, then blow from outside of filter.

NG**Repair or replace.****OK****5 Check engine idle speed.****PREPARATION:**

- (a) Warm up engine to normal operating temperature.
- (b) Switch off all accessories.
- (c) Switch off air conditioning.
- (d) Shift transmission into "N" position.
- (e) Connect the hand-held tester to the DLC3 on the vehicle.

CHECK:

Use **CURRENT DATA** to check the idle speed.

OK:

Idle speed: 650 – 750 rpm

NG**Proceed to problem symptoms table on [page DI-24](#).****OK**

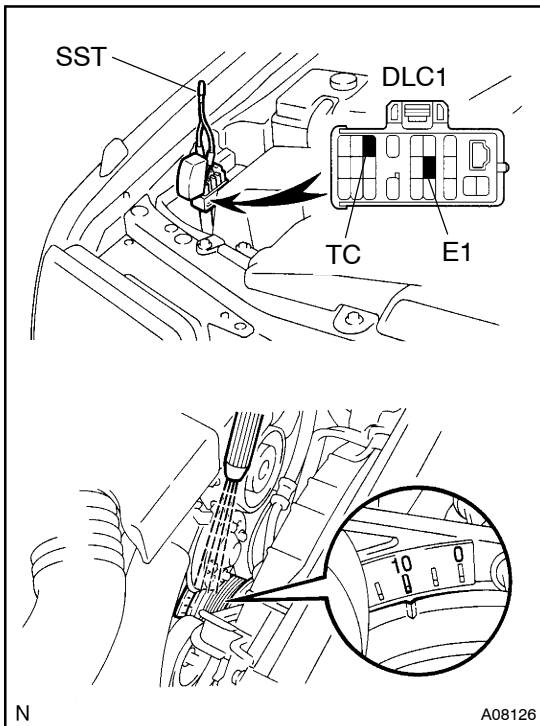
6 Check Ignition Timing.**PREPARATION:**

- Warm up the engine to normal operating temperature.
- Shift transmission into "N" position.
- Keep the engine speed at idle.
- Using SST, connect terminals TC and E1 of the check connector.
SST 09843-18020
- Using a timing light, connect the tester to the No. 1 high-tension cord.

CHECK:

Check Ignition Timing.

OK:

Ignition timing: $3 - 12^\circ$ BTDC at idle

NG

Proceed to [page G-1](#) and continue to troubleshoot.

OK

Proceed to problem symptoms table on [page DI-24](#).

7 Check fuel pressure.

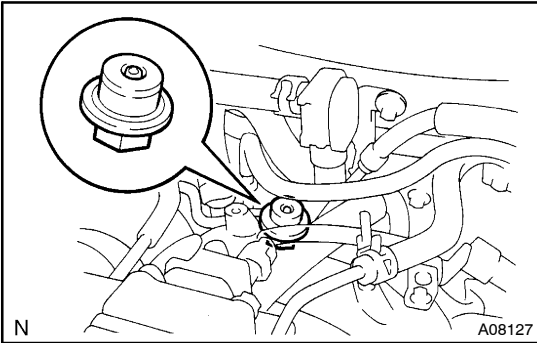

PREPARATION:

- Be sure that enough fuel is in the tank.
- Turn the ignition switch ON.
- Connect the hand-held tester to the DLC3.
- Use ACTIVE TEST mode to operate the fuel pump.
- If you have no hand-held tester, connect the positive (+) and negative (-) leads from the battery to the fuel pump connector (See page FI-6).

CHECK:

Check that the pulsation damper screw rises up when the fuel pump operates.

NG

Proceed to [page FI-6](#) and continue to troubleshoot.

OK

8 Check for spark.

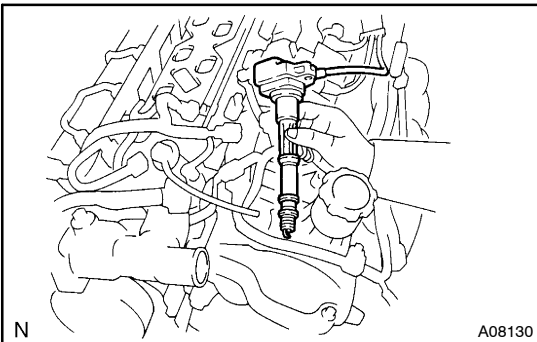

PREPARATION:

- Remove ignition coil.
- Remove the spark plug.
- Install the spark plug to the ignition coil, and connect the ignition coil connector.
- Hold the end about 12.5 mm (0.5 in.) from the ground.
- Disconnect the injector connector.

CHECK:

Check if spark occurs while engine is being cranked.

NOTICE:

To prevent excess fuel being injected from the injectors during this test, don't crank the engine for more than 5 - 10 seconds at a time.

NG

Proceed to [page G-1](#) and continue to troubleshoot.

OK

Proceed to [problem symptoms table on page DI-24](#).

7. ENGINE OPERATING CONDITION (Hand-held tester only)**NOTICE:**

The values given below for "Normal Condition" are representative values, so a vehicle may still be normal even if its value from those listed here. So do not decide whether a part is faulty or not solely according to the "Normal Condition" here.

Hand-held tester display	Measurement Item	Normal Condition*
FUEL SYS #1	Fuel System OPEN: Air-fuel ratio feedback stopped CLOSED: Air-fuel ratio feedback operating	Idling after warming up: CLOSED
CALC LOAD	Calculator Load: Current intake air volume as a proportion of max. intake air volume	Idling: 13.9 – 19.7 % Racing without load (2,500rpm): 13.9 – 9.7 %
COOLANT TEMP.	Engine Coolant Temp. Sensor Value	After warming up: 80 – 95°C (176 – 203°F)
SHORT FT #1	Short-term Fuel Trim	0 ± 20 %
LONG FT #1	Long-term Fuel Trim	0 ± 20 %
ENGINE SPD	Engine Speed	Idling: 600 – 700 rpm
VEHICLE SPD	Vehicle Speed	Vehicle stopped: 0 km/h (0 mph)
IGN ADVANCE	Ignition Advance: Ignition Timing of Cylinder No. 1	Idling: BTDC 10 ± 2°
INTAKE AIR	Intake Air Temp. Sensor Value	Equivalent to ambient temp.
AFM	Air Flow Rate Through Mass Air Flow Meter	Idling: 4.0 – 5.6 gm/sec. Racing without load (2,500 rpm): 13.2 – 18.7 gm/sec.
THROTTLE POS	Voltage Output of Throttle Position Sensor Calculated as a percentage: 0 V → 0 %, 5 V → 100 %	Throttle fully closed: 8 – 20 % Throttle fully open: 64 – 96 %
O2S B1, S1	Voltage Output of Oxygen Sensor Sensor 1	Idling: 0.1 – 0.9 V
O2S B1, S2	Voltage Output of Oxygen Sensor Sensor 2	Driving (50 km/h, 31 mph): 0.1 – 0.9 V

*: If no conditions are specifically stated for "Idling", it means the shift lever is at N or P position, the A/C switch is OFF and all accessory switches are OFF.

DIAGNOSTICS - ENGINE

Hand-held tester display	Measurement Item	Normal Condition*
INJECTOR	Fuel injection time for cylinder No.1	Idling: 1.8 ~ 3.2 ms
STARTER SIG	Starter Signal	Cranking: ON
A/C SIG	A/C Switch Signal	A/C ON: ON
NSW	Neutral Start Switch Signal	P or N position: ON
IDL SIG	Closed Throttle Position	Throttle fully closed: ON
STOP LIGHT SW	Stop Light Switch Signal	Stop light switch ON: ON
FC IDL	Fuel Cut Idle: Fuel cut when throttle valve fully closed, during deceleration	Fuel cut operating: ON
FC TAU	Fuel Cut TAU: Fuel cut during very light load	Fuel cut operating: ON
FUEL PUMP	Fuel Pump Signal	Idling: ON
EVAP (PURGE) VSV	EVAP VSV Signal	VSV operating: ON
ACCEL POS	Accelerator pedal position sensor No.1 output voltage	Accelerator pedal released: 0.25 ~ 0.9 V Accelerator pedal depressed: 3.2 ~ 4.8 V
ACCEL POS #2	Accelerator pedal position sensor No.2 output voltage	Accelerator pedal released: 1.8 ~ 2.7 V Accelerator pedal depressed: 4.7 ~ 5.0 V
THROTTLE TARGET POS	Target position of throttle valve	Idling: 0.4 ~ 1.1 V
THROTTLE MOTOR CTL	Whether or not throttle motor control is permitted	Idling: ON
+BM	Whether or not electric throttle control system power is inputted	Idling: ON
ACCEL IDL	Whether or not accelerator pedal position sensor is detecting idle	Idling: ON
THROTTLE IDL	Whether or not throttle position sensor is detecting idle	Idling: ON
FAIL #1	Whether or not fail safe function is executed	ETCS is failed: ON

*: If no conditions are specifically stated for "Idling", it means the shift lever is at N or P position, the A/C switch is OFF and all accessory switches are OFF.