

# CYLINDER HEAD COMPONENTS

EM10P-02

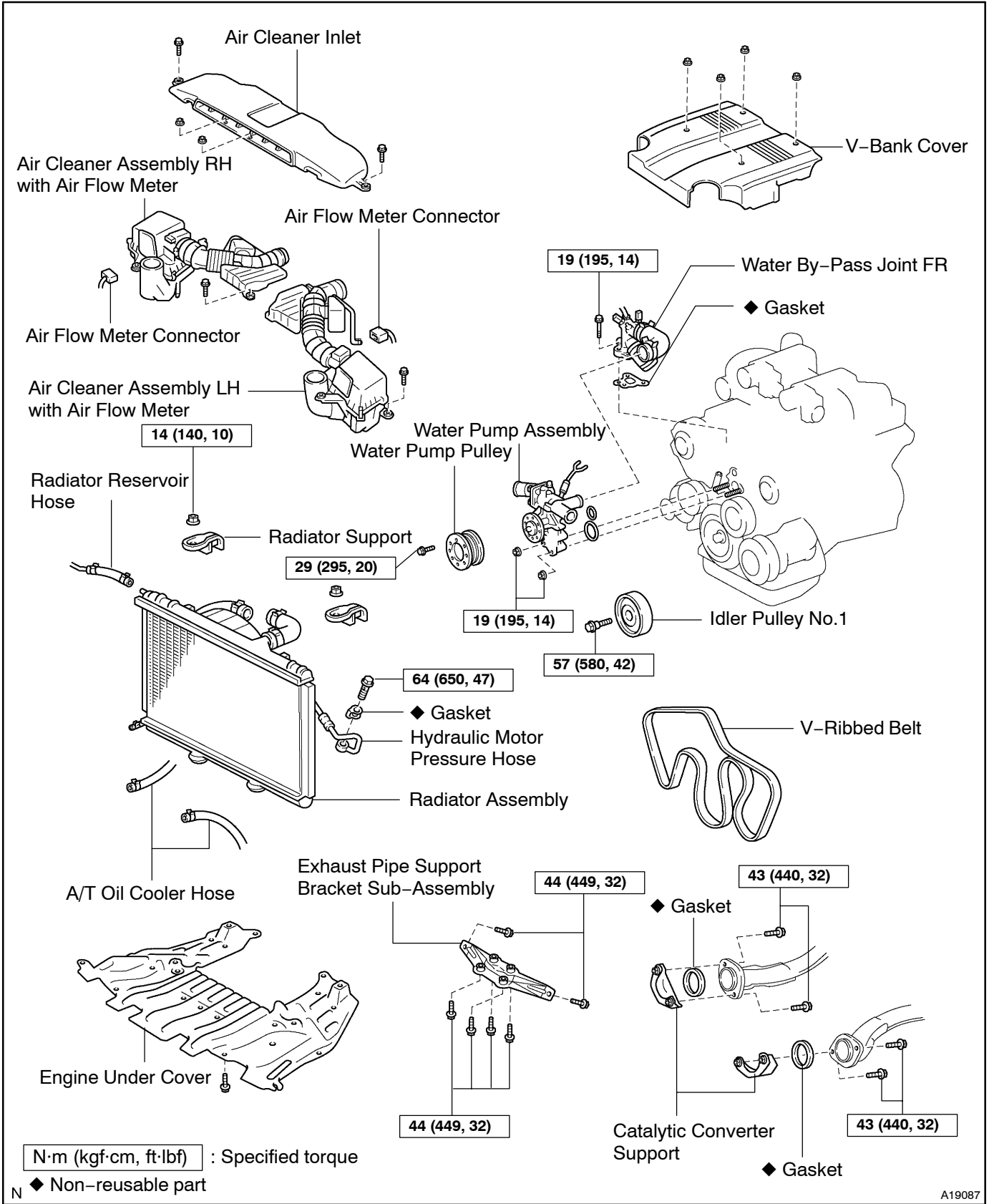

A19087

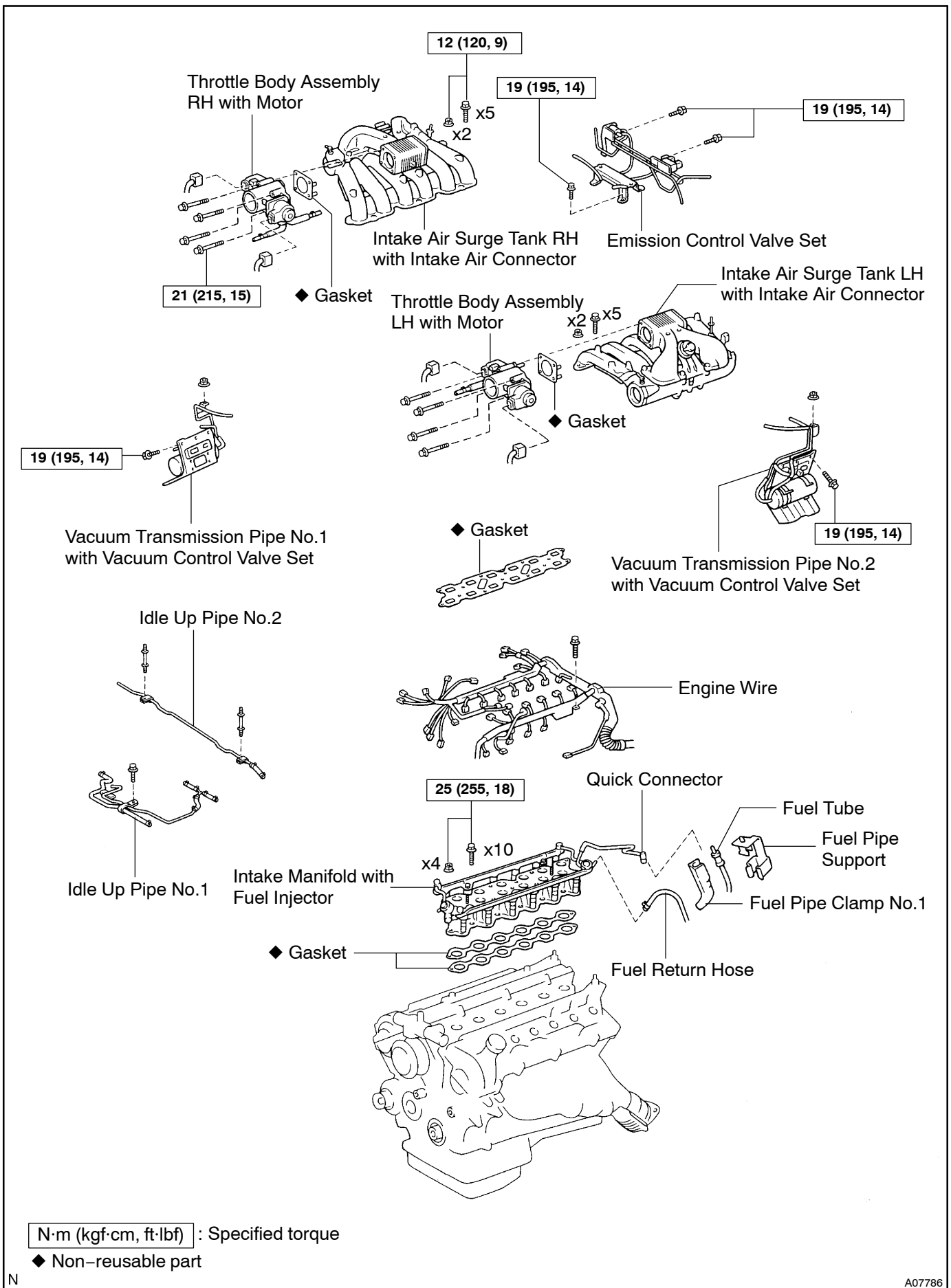

N

A07786

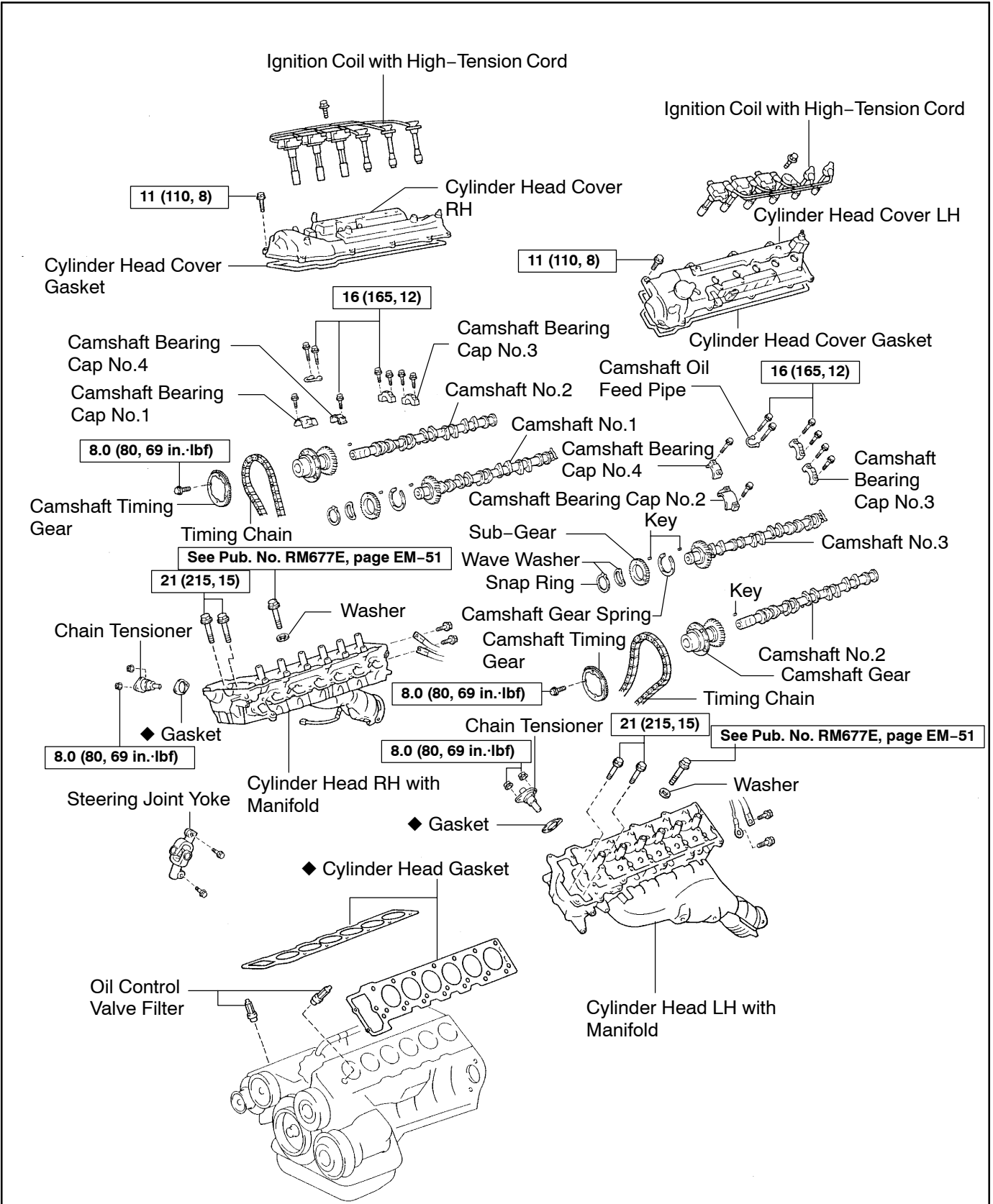

**N-m (kgf-cm, ft-lbf) : Specified torque**

**◆ Non-reusable part**

N

A07791

