

Starter Signal Circuit

CIRCUIT DESCRIPTION

When the engine is cranked, the intake air flow is slow, so fuel vaporization is poor. A rich mixture is therefore necessary in order to achieve good startability. While the engine is being cranked, the battery positive voltage is applied to terminal STA of the engine ECU. The starter signal is mainly used to increase the fuel injection volume for the starting injection control and after-start injection control.

WIRING DIAGRAM

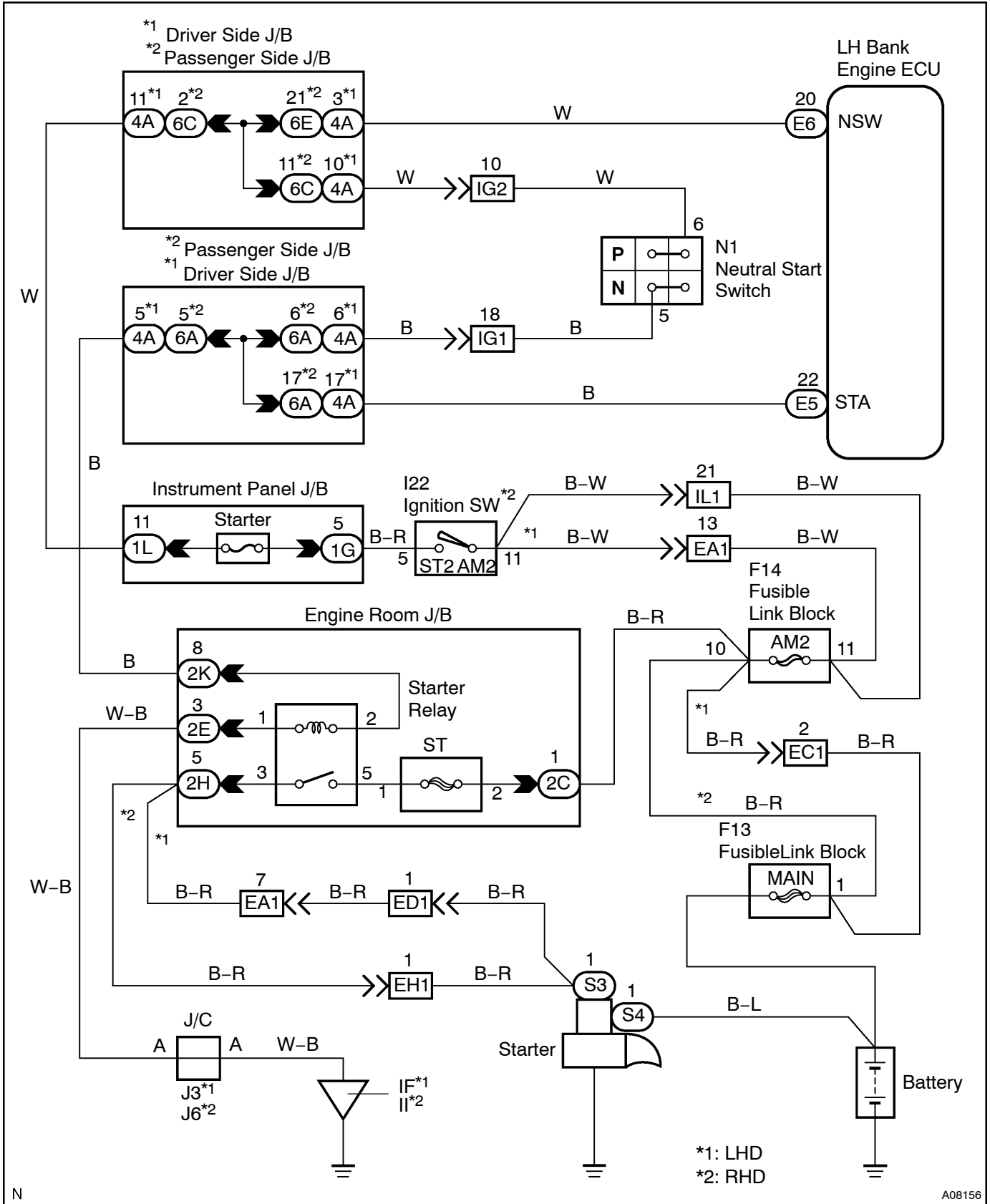

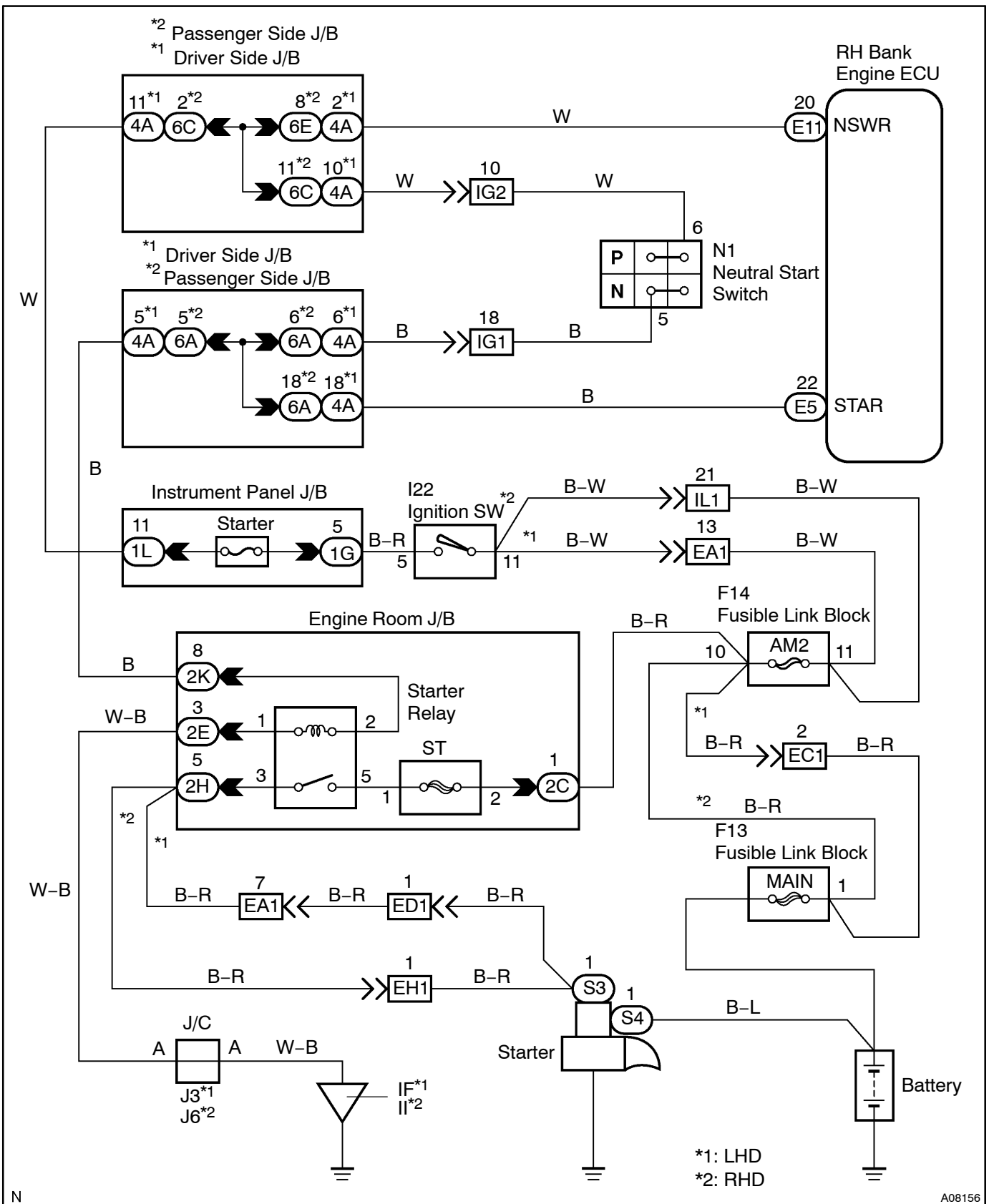

INSPECTION PROCEDURE

HINT:

- The inspection procedures are same for both LH and RH bank engine ECU and described in this manual. Even though terminal name and part name on the side of RH bank are described in parenthesis, perform the inspection for only defective ECU.
- This diagnostic chart is based on the premise that the engine is cranked normally. If the engine is not cranked, proceed to the problem symptoms table on [page DI-23](#).

When using hand-held tester

1	Connect hand-held tester and check STA signal.
----------	---

PREPARATION:

- Connect the hand-held tester to the DLC3.
- Turn the ignition switch to ON and push the hand-held tester main switch to ON.

CHECK:

Read STA signal on the hand-held tester while starter operates.

OK:

Ignition Switch Position	ON	START
STA signal	OFF	ON

OK

Proceed to next circuit inspection shown on problem symptoms table ([See page DI-23](#)).

NG

2	Check for open in harness and connector between engine ECU and starter relay (Marking: STARTER) (See page N-20).
----------	---

NG

Repair or replace harness or connector.

OK

Check and replace engine ECU (See page N-20).
--

When not using hand-held tester

- 1 Check voltage between terminal STA (STAR) of engine ECU connector and body ground.**

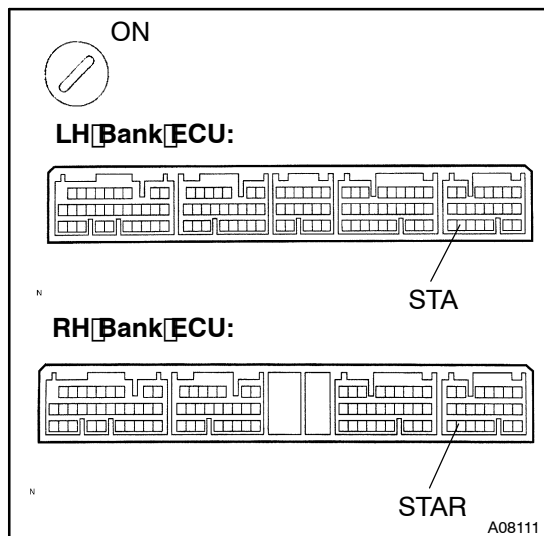

PREPARATION:

- Remove the engine ECU with connectors still connected.
- Turn the ignition switch to ON.

CHECK:

Measure voltage between terminal STA (STAR) of the engine ECU connector and body ground, during engine cranking.

OK:

Voltage: 6 V or more

OK

Proceed to next circuit inspection shown on problem/symptoms table (See page DI-23).

NG

- 2 Check for open in harness and connector between engine ECU and starter relay (See page IN-20).**

NG

Repair or replace harness or connector.

OK

Check and replace engine ECU (See page IN-20).