

## INSPECTION

### 1. INSPECT ROTOR FOR OPEN CIRCUIT

Using an ohmmeter, check that there is continuity between the slip rings.

**Standard resistance: 2.1 – 2.5  $\Omega$  at 20°C (68°F)**

If there is no continuity, replace the rotor.

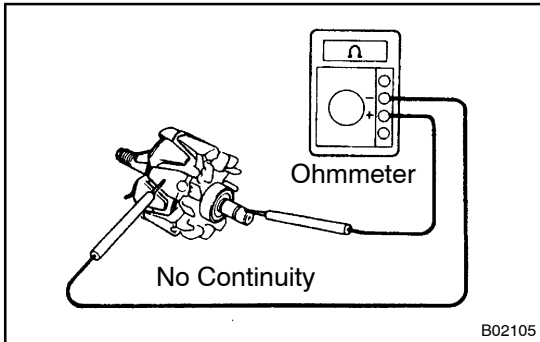

### 2. INSPECT ROTOR FOR GROUND

Using an ohmmeter, check that there is no continuity between the slip ring and rotor.

If there is continuity, replace the rotor.

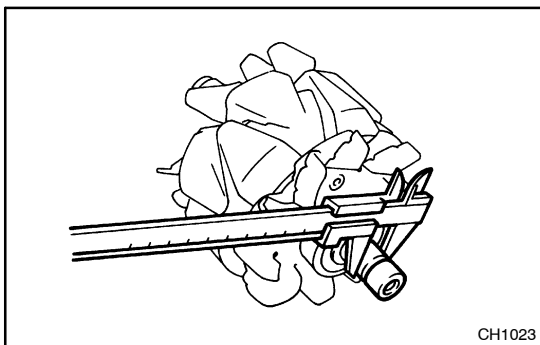

### 3. INSPECT SLIP RINGS

(a) Check that the slip rings are not rough or scored.

If rough or scored, replace the rotor.

(b) Using vernier calipers, measure the slip ring diameter.

**Standard diameter: 14.2 – 14.4 mm (0.559 – 0.567 in.)**

**Minimum diameter: 12.8 mm (0.504 in.)**

If the diameter is less than minimum, replace the rotor.

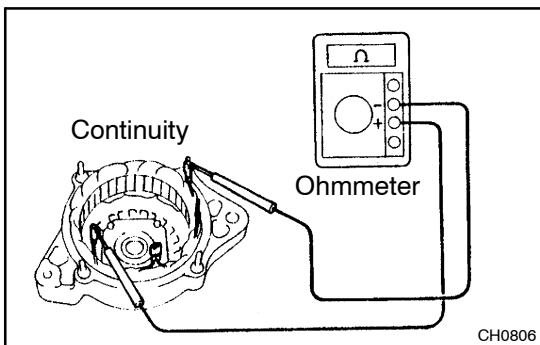

### 4. INSPECT STATOR FOR OPEN CIRCUIT

Using an ohmmeter, check that there is continuity between the coil leads.

If there is no continuity, replace the drive end frame assembly.

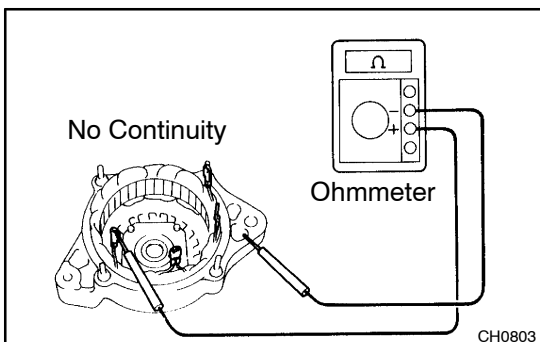

### 5. INSPECT STATOR FOR GROUND

Using an ohmmeter, check that there is no continuity between the coil lead and drive end frame.

If there is continuity, replace the drive end frame assembly.

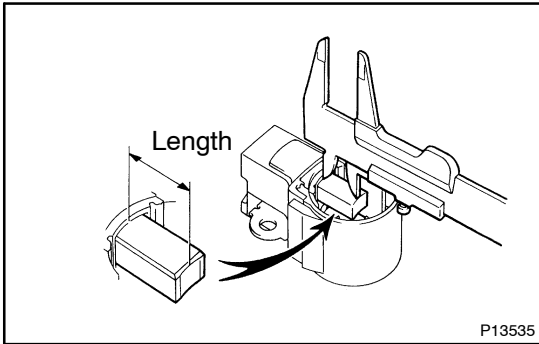

## 6. INSPECT EXPOSED BRUSH LENGTH

Using vernier calipers, measure the exposed brush length.

**Standard exposed length:**

**9.5 – 11.5 mm (0.374 – 0.452 in.)**

**Minimum exposed length:**

**1.5 mm (0.059 in.)**

If the exposed length is less than minimum, replace the brush holder.

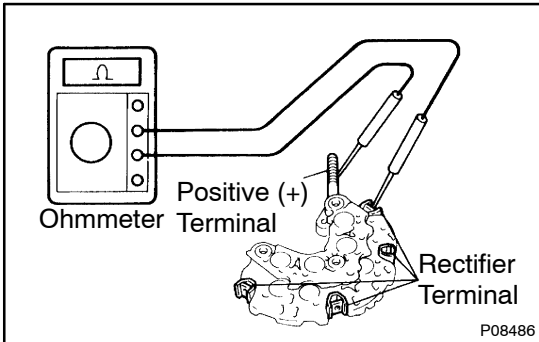

## 7. INSPECT POSITIVE RECTIFIER

- Using an ohmmeter, connect one tester probe to the positive (+) terminal and the other to each rectifier terminal.
- Reverse the polarity of the tester probes and repeat step (a).
- Check that one shows continuity and the other shows no continuity.

If continuity is not as specified, replace the rectifier holder.

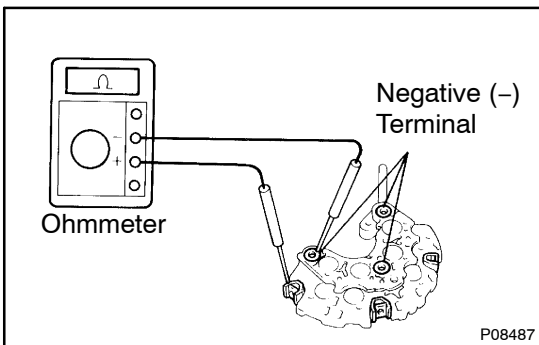

## 8. INSPECT NEGATIVE RECTIFIER

- Using an ohmmeter, connect one tester probe to each negative (-) terminal and the other to each rectifier terminal.
- Reverse the polarity of the tester probes and repeat step (a).
- Check that one shows continuity and the other shows no continuity.

If continuity is not as specified, replace the rectifier holder.

## 9. INSPECT FRONT AND REAR BEARING

Check that the bearing is not rough or worn.

If necessary, replace the bearing.