

Tc Terminal Circuit

CIRCUIT DESCRIPTION

Connecting between terminals Tc and E₁ of the check connector or Tc and CG of the DLC3 causes the ECU to display the DTC by flashing the ABS warning light.

WIRING DIAGRAM

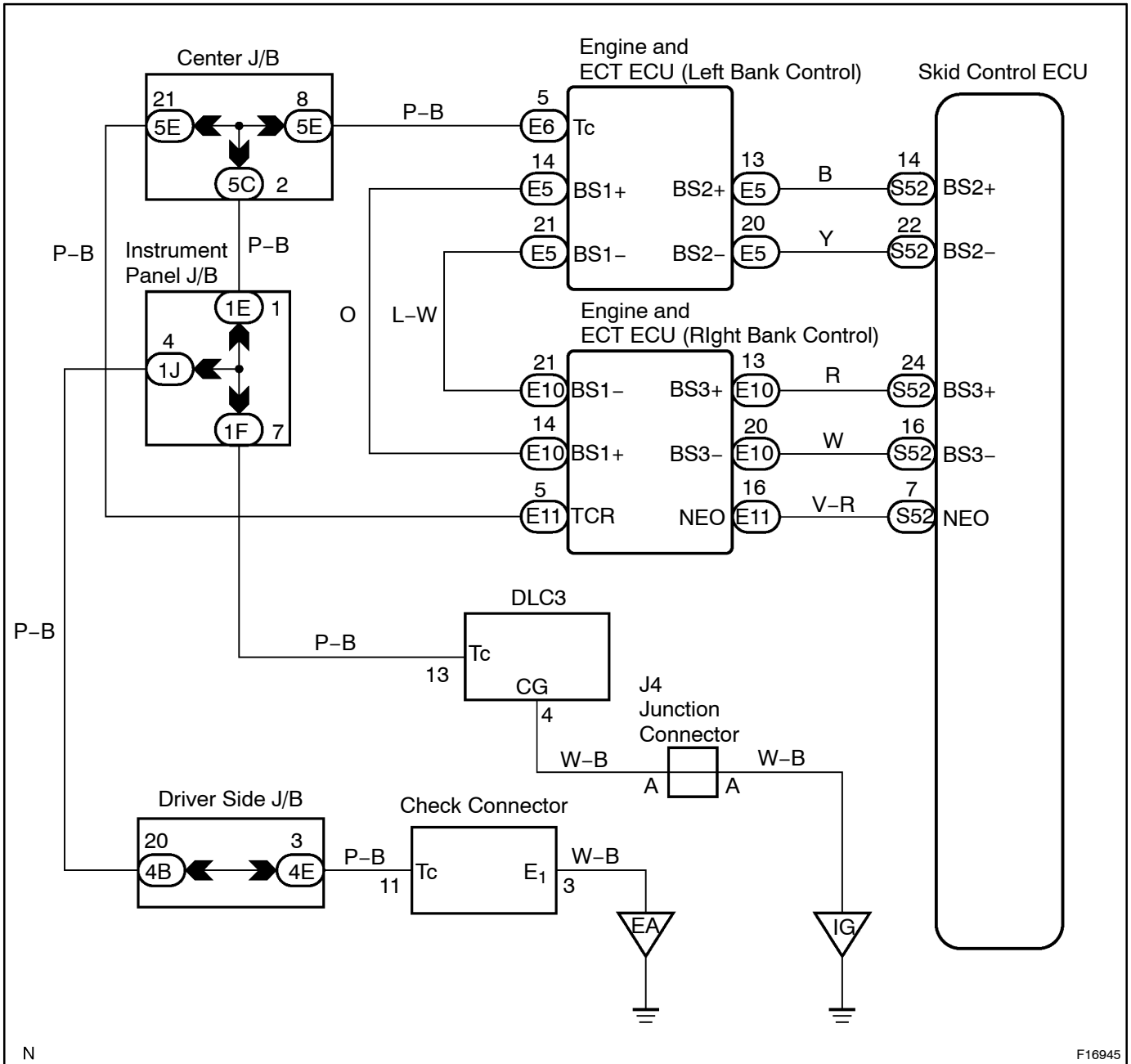

N

F16945

INSPECTION PROCEDURE

- 1 Check voltage between terminals Tc and E₁ of check connector or Tc and CG of DLC3.

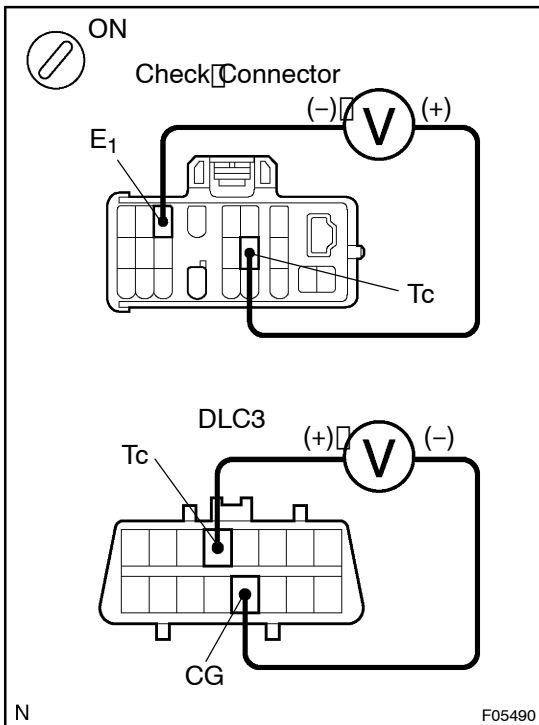
**CHECK:**

- (a) Turn the ignition switch to ON.
 (b) Measure voltage between terminals Tc and E₁ of the check connector or Tc and CG of the DLC3.

OK:

Voltage: 10 - 14 V

OK

If ABS warning light does not blink even after Tc and E₁ or Tc and CG are connected, the skid control ECU may be defective.

NG

- 2 Check for open and short circuit in harness and connector between skid control ECU and check connector or DLC3, check connector or DLC3 and body ground (See page N-31).

NG

Repair or replace harness or connector.

OK

Check and replace skid control ECU.