

OIL PUMP COMPONENTS

LU0GA-01

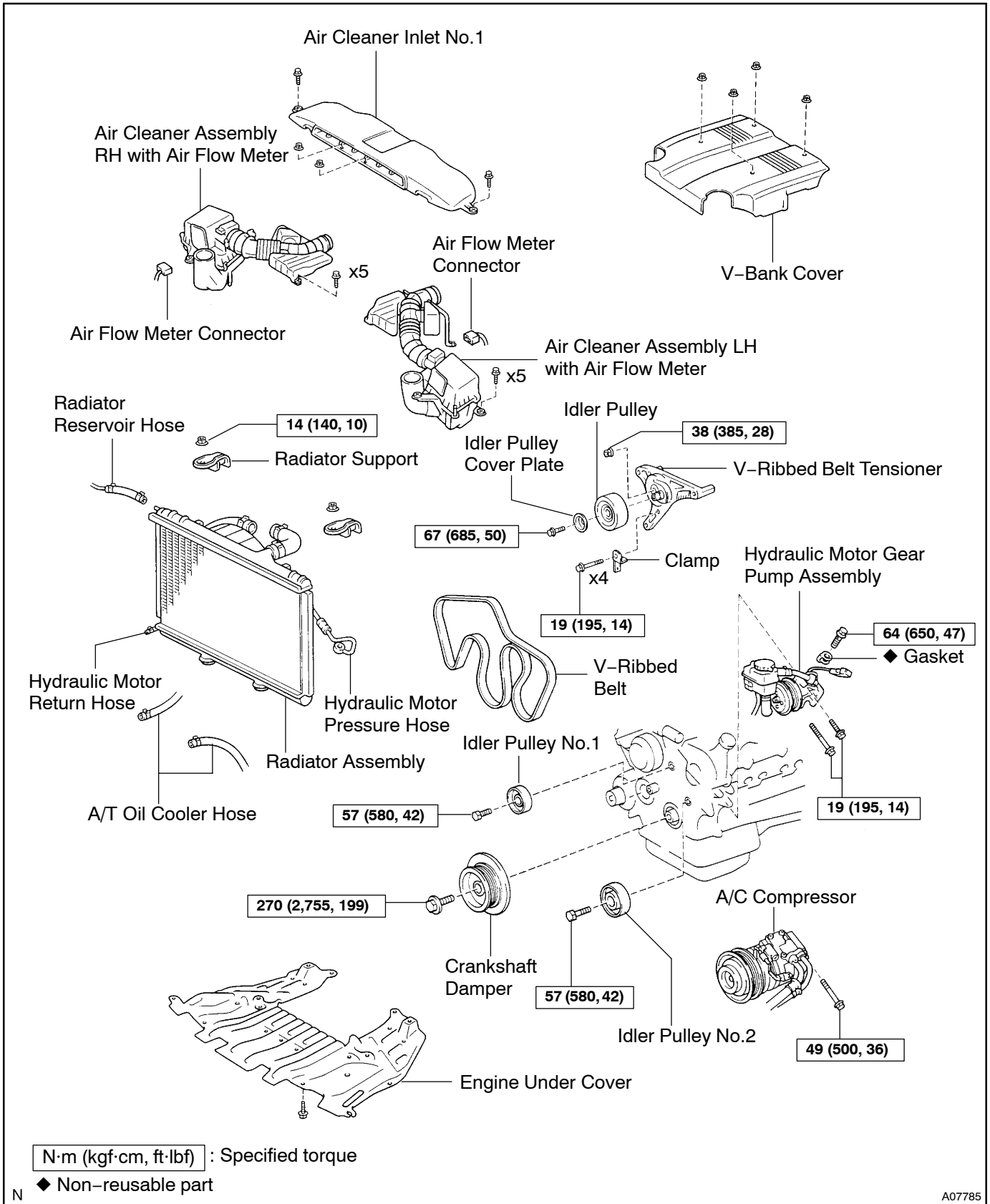

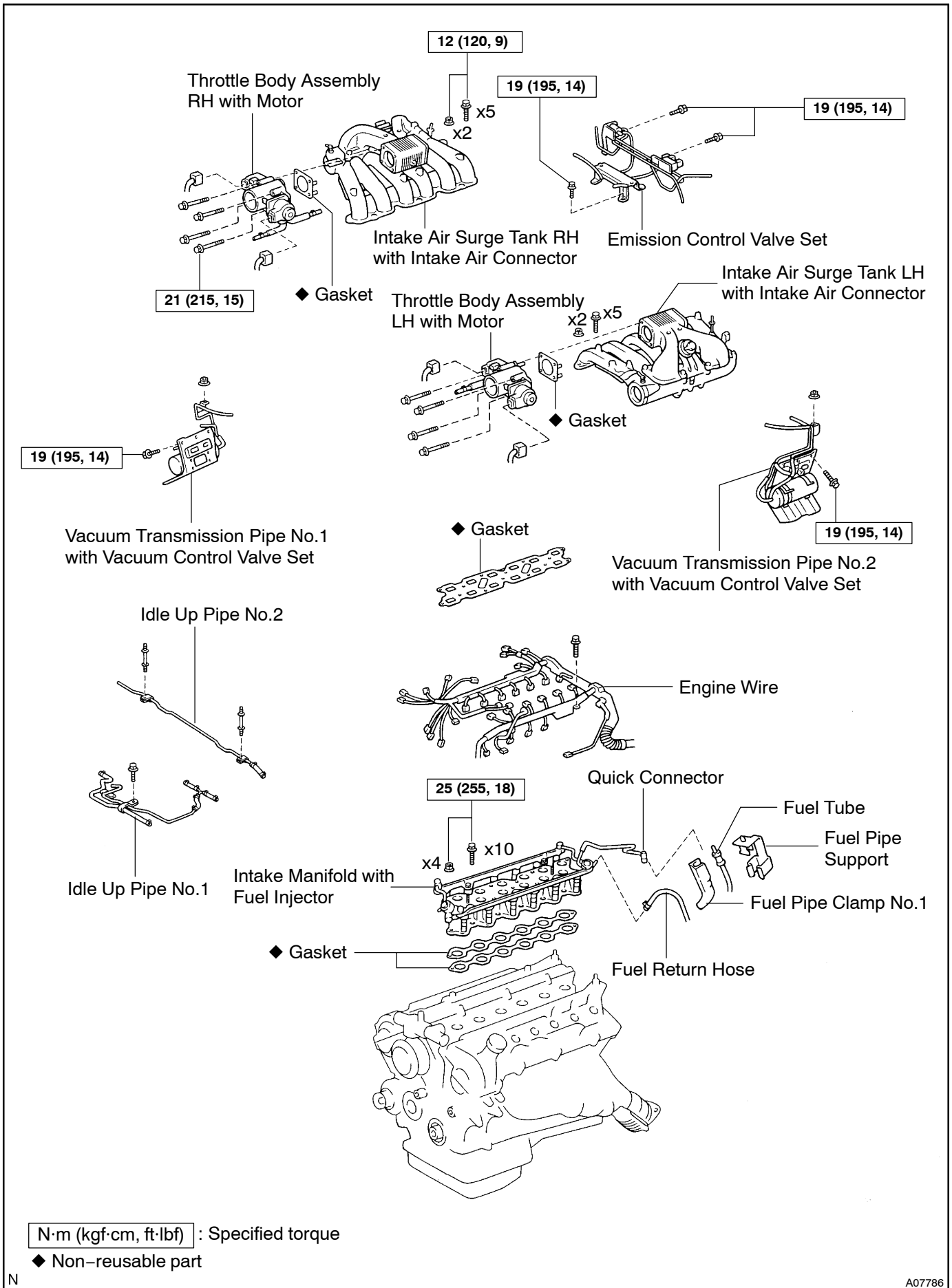

N·m (kgf·cm, ft·lbf) : Specified torque

◆ Non-reusable part

LUBRICATION - OIL PUMP

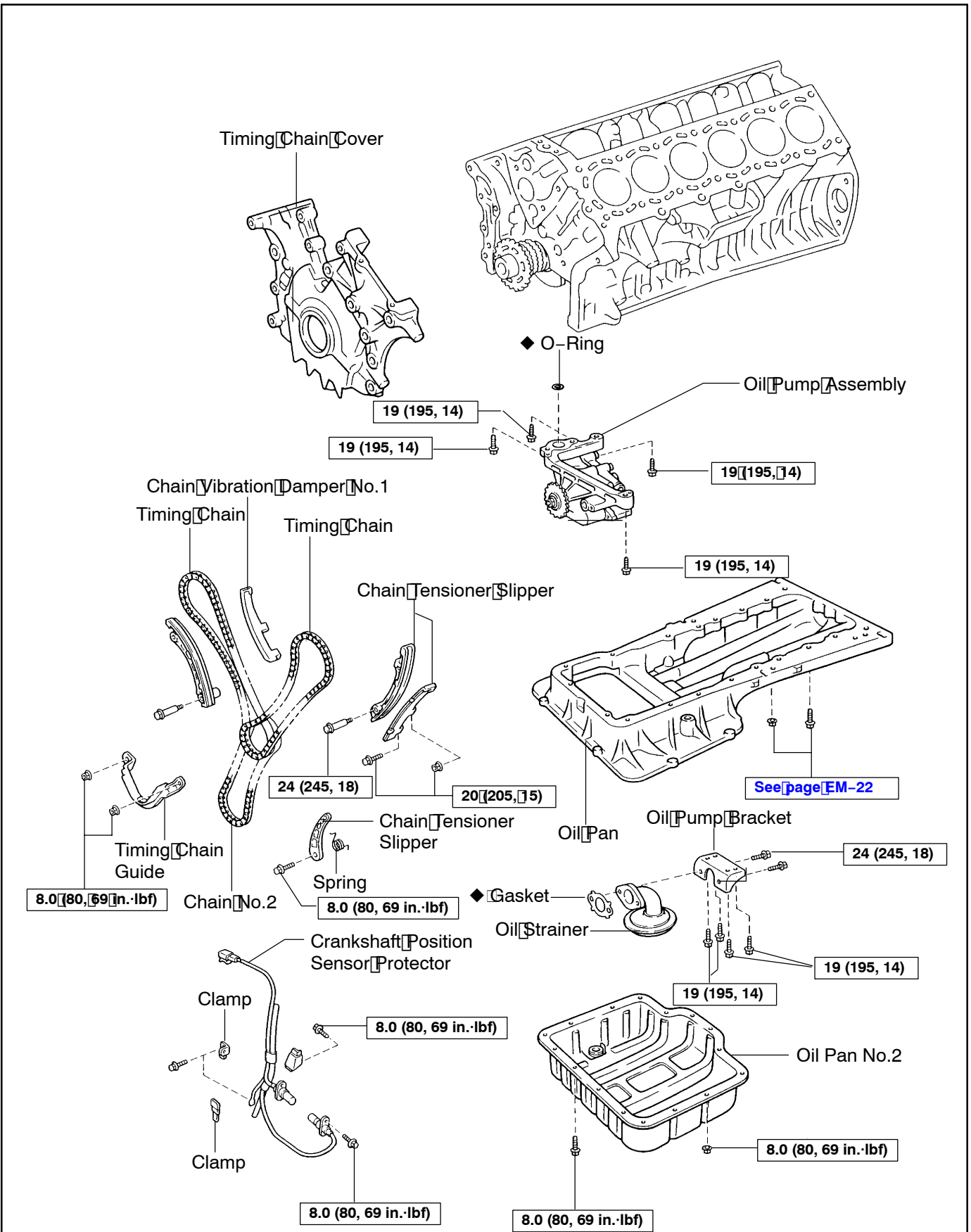

N·m (kgf·cm, ft·lbf) : Specified torque

◆ Non-reusable part

N

B07129

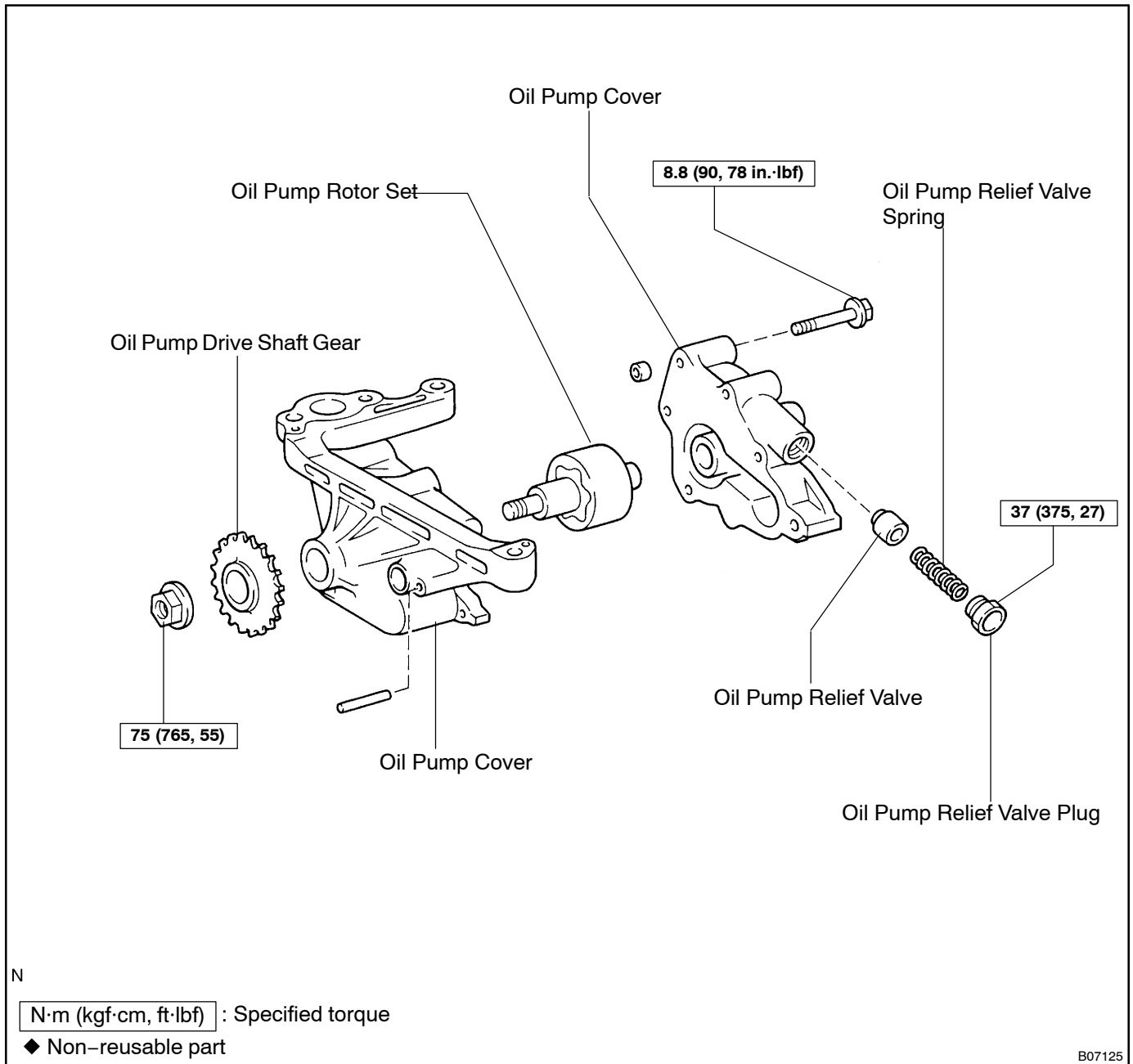

B07125