

DTC	21	Solar Sensor Circuit
------------	-----------	-----------------------------

CIRCUIT DESCRIPTION

A photo diode in the solar detects solar radiation and sends signals to the A/C control assembly.

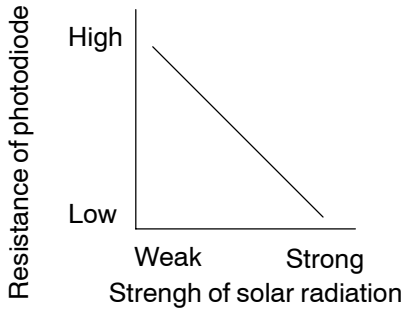

DTC No.	Detection Item	Trouble Area
21	Open or short in solar sensor circuit. (Please note that display of DTC 21 is not abnormal when the sensor is not receiving solar radiation.)	<ul style="list-style-type: none"> • Solar sensor. • Harness or connector between solar sensor and A/C control assembly. • A/C control assembly.

WIRING DIAGRAM

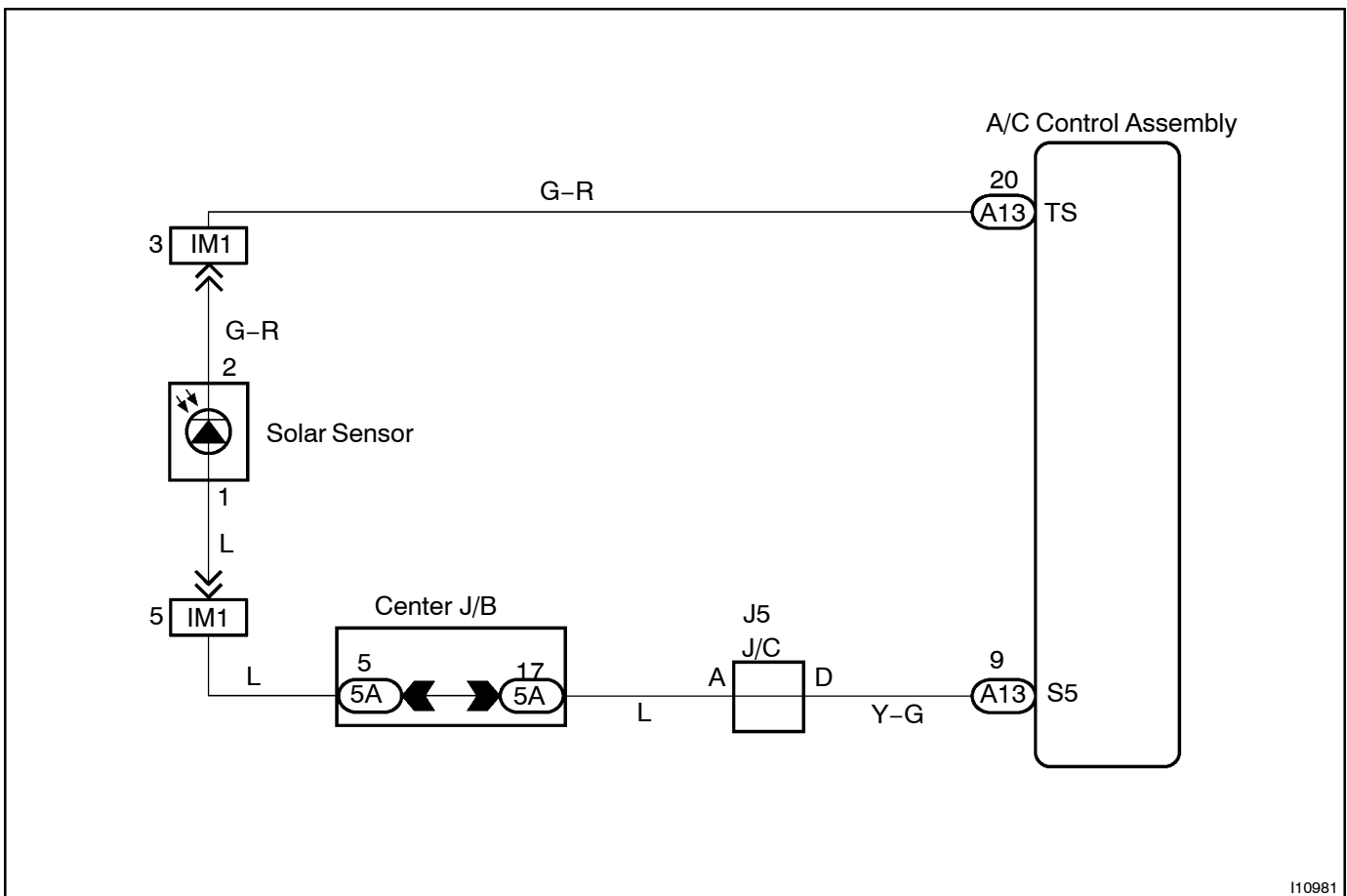

I10981

INSPECTION PROCEDURE

1 Check voltage between terminals TS and SG of A/C control assembly connector.

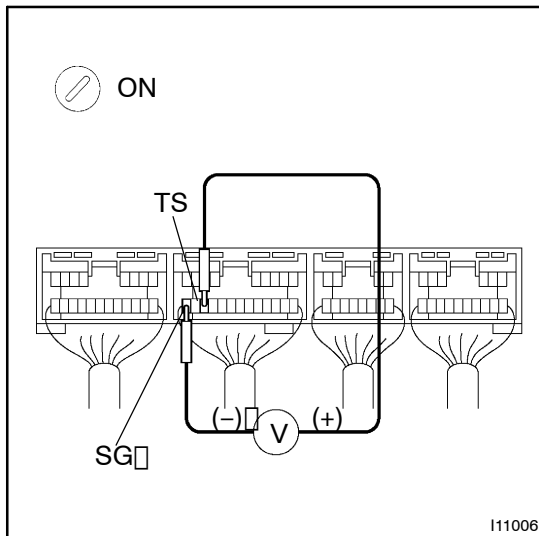
**PREPARATION:**

Remove A/C control assembly with connectors still connected.

CHECK:

- (a) Turn ignition switch to ON.
- (b) Measure voltage between terminals TS and SG of A/C control assembly connector when the solar sensor is subjected to an electric light and when the sensor is covered by a cloth.

OK:

Condition	Voltage
Sensor is subjected to electric light	more than 1 V
Sensor is covered by a cloth	less than 1 V

HINT:

As the inspection light is moved away from the sensor, the voltage increases.

NG

Go to step 2.

OK

Proceed to next circuit inspection shown on problem symptoms table (See page DI-780). However, if DTC 21 is displayed, check and replace A/C control assembly.

2 Check solar sensor.

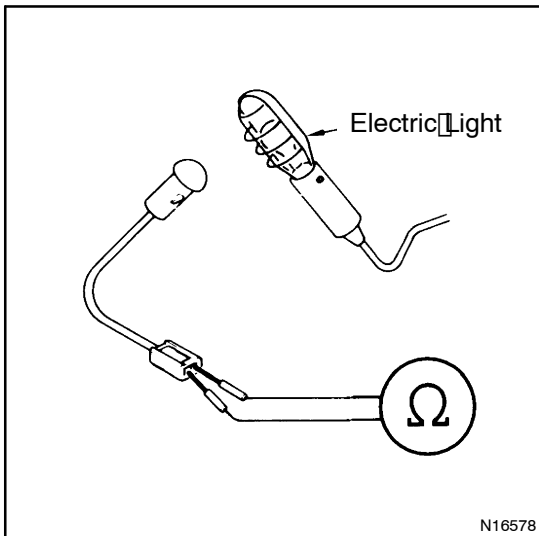

PREPARATION:

Remove solar sensor (See page AC-94).

CHECK:

- Cover the sensor with a cloth.
- Measure resistance between terminals 1 and 2 of solar sensor connector.

HINT:

Connect positive (+) lead of ohmmeter to terminal 1 and negative (-) lead to terminal 2 of the solar sensor.

OK:

Resistance: $\infty \Omega$ (no continuity)

CHECK:

- Remove the cloth from the solar sensor and subject the sensor to electric light.
- Measure resistance between terminals 1 and 2 of solar sensor.

OK:

Resistance: Approx. 4 k Ω (continuity)

HINT:

As the electric light is moved away from the sensor, the resistance increases.

NG

Replace solar sensor.

OK

3 Check harness and connector between A/C control assembly and solar sensor (See page IN-30).

NG

Repair or replace harness or connector.

OK

Check and replace A/C control assembly.