

PRE-CHECK

1. DIAGNOSIS SYSTEM

(a) Check the Indicator.

- (1) Turn the ignition switch to ON.
- (2) Check that the CRUISE MAIN indicator light comes on when the cruise control main switch is turned ON, and that the indicator light goes off when the main switch is turned OFF.

HINT:

If the indicator check result is not normal, proceed to troubleshooting (See page BE-2) for the combination meter section.

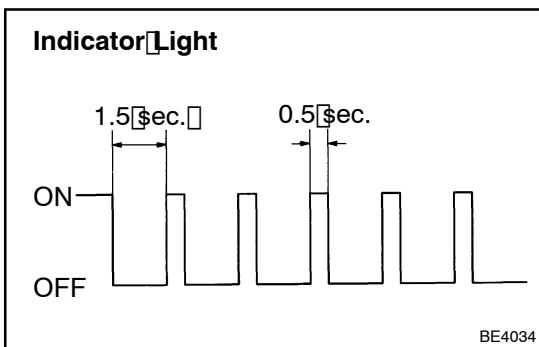

(b) Check the DTC.

HINT:

If a malfunction occurs in the speed sensor or actuator, etc. during cruise control driving, the ECU actuates AUTO CANCEL of the cruise control and turns ON and OFF the CRUISE MAIN indicator light to inform the driver of a malfunction. At the same time, the malfunction is stored in memory as a diagnostic trouble code.

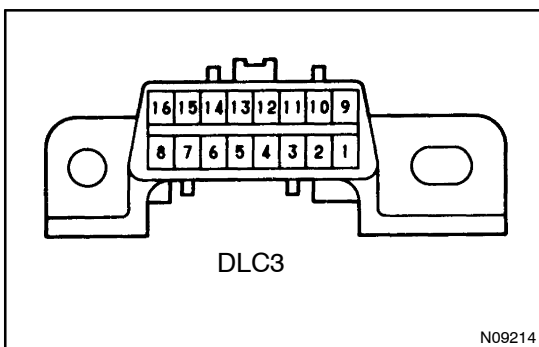

(c) Output DTC using diagnosis check wire.

- (1) Turn the ignition switch ON.
- (2) Using SST, connect terminals Tc and E₁ of DLC3.
SST 09843-18020
- (3) Read the DTC on the CRUISE MAIN indicator light.

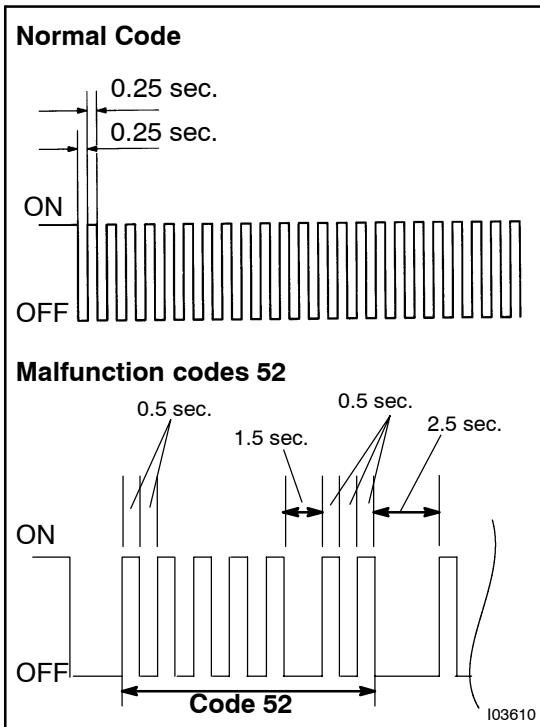
**HINT:**

If the DTC is not output, inspect the diagnosis circuit.

As an example, the blinking patterns for codes; normal 52 are shown in the illustration.

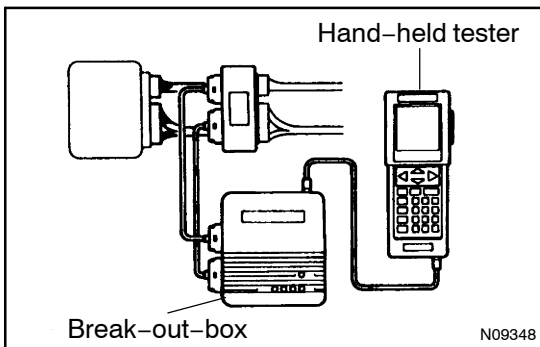

2. ECU TERMINAL VALUES MEASUREMENT BY USING BREAK-OUT-BOX AND HAND-HELD TESTER

- (a) Hook up the break-out-box and hand-held tester to the vehicle.
- (b) Read the ECU input/output values by following the prompts on the tester screen.
- (c) Please refer to the hand-held tester has a "Snapshot" function. This records the measured data and is effective in the diagnosis of intermittent problems.

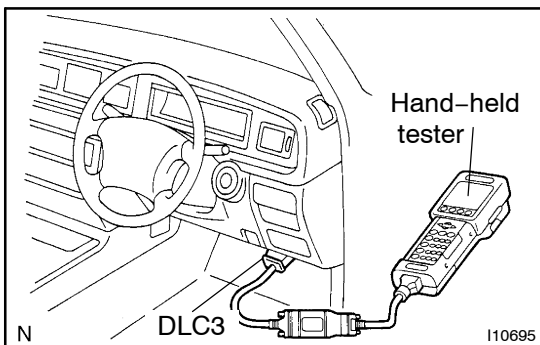

3. USING HAND-HELD TESTER

- (a) Hook up the hand-held tester to the DLC3.
- (b) Monitor the ECU data by following the prompts on the tester screen.

HINT:

Hand-held tester has a "Snapshot" function which records the monitored data.

Please refer to the hand-held tester operator's manual for further details.

4. DTC CLEARANCE

- (a) The following actions will erase the DTCs and freeze frame data.
- (1) Operating the OBD II scan tool (complying with SAEJ1978) or hand-held tester to erase the codes. (See the OBD II scan tool's instruction book for operating instructions.)
 - (2) Disconnecting the battery terminals or EFI fuse.
- (b) After completing repairs, the DTC retained in memory can be cleared by removing the ECU-B fuse for 10 seconds or more with the ignition switch off.
- (c) Check that the normal code is displayed after connecting the fuse.

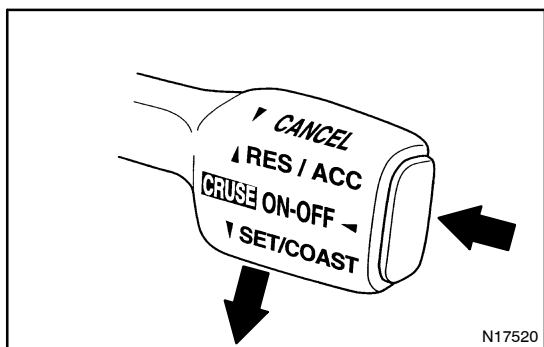
**5. PROBLEM SYMPTOM CONFIRMATION (ROAD TEST)**

- (a) Inspect the SET switch.
- (1) Push the main switch ON.
 - (2) Drive at a desired speed (40 km/h (25 mph) or higher).
 - (3) Press the control switch to the SET/COAST.
 - (4) After releasing the switch, check that the vehicle cruises at the desired speed.
- (b) Inspect the ACCEL switch.
- (1) Push the main switch ON.
 - (2) Drive at a desired speed (40 km/h (25 mph) or higher).
 - (3) Check that the vehicle speed increases while the control switch is turned to RES/ACC, and that the vehicle cruises at the set speed when the switch is released.
 - (4) Momentarily press the control switch upward in the RES/ACC and then immediately release it. Check that the vehicle speed increases by about 1.5 km/h (Tap-up function).

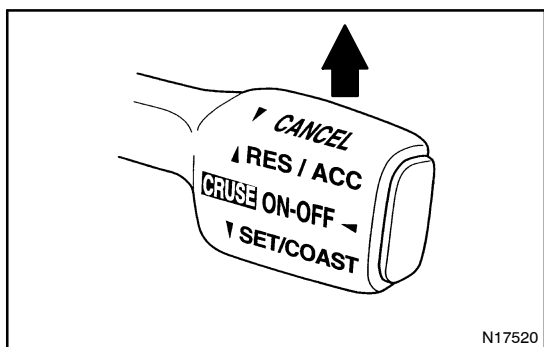

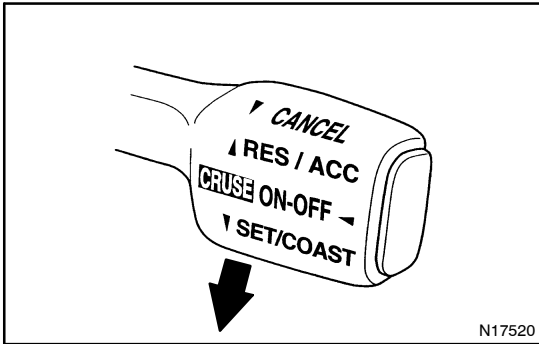

- (c) Inspect the COAST switch.
- (1) Push the main switch ON.
 - (2) Drive at a desired speed (40 km/h (25 mph) or higher).
 - (3) Check that the vehicle speed decreases while the control switch is turned to SET/COAST, and the vehicle cruises at the set speed when the switch is released.
 - (4) Momentarily press the control switch is turned to SET/COAST, and then immediately release it. Check that the vehicle speed decreases by about 1.5 km/h (Tap-down function).

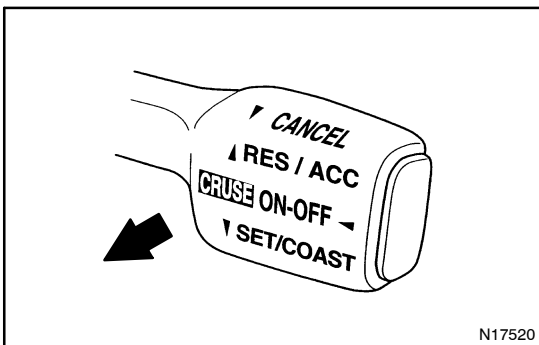

- (d) Inspect the CANCEL switch.
- (1) Push the main switch ON.
 - (2) Drive at a desired speed (40 km/h (25 mph) or higher).
 - (3) When operating one of the followings, check that the cruise control system is cancelled and that the normal driving mode is reset.
 - Depress the brake pedal
 - Shift to except D position (A/T)
 - Push the main switch OFF
 - Pull the cruise control switch to CANCEL

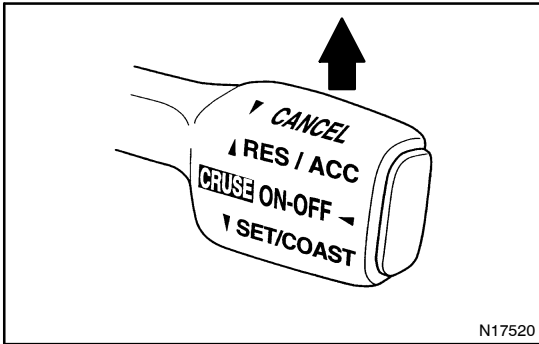

- (e) Inspect the RESUME switch.
- (1) Push the main switch ON.
 - (2) Drive at a desired speed (40 km/h (25 mph) or higher).
 - (3) When operating one of the followings, check that the cruise control system is cancelled and that the normal driving mode is reset.
 - Depress the brake pedal
 - Shift to except D position (A/T)
 - Pull the cruise control switch to CANCEL
 - (4) After the control switch is turned to RES/ACC at the driving speed of more than 40 km/h (25 mph), check that the vehicle restores the speed prior to the cancellation.

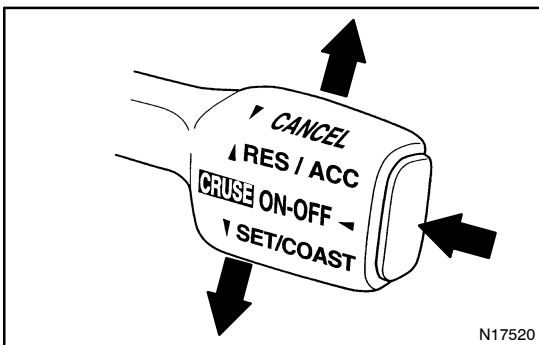

6. INPUT SIGNAL CHECK (Using hand-held tester)

- (a) Connect the hand-held tester to DLC3
- (b) Check the control switch (MAIN, CANCEL, SET/COAST, RES/ACC)