

## FRONT SIDE MEMBER (CUT-P)

REMOVAL (With the front fender front apron removed.)

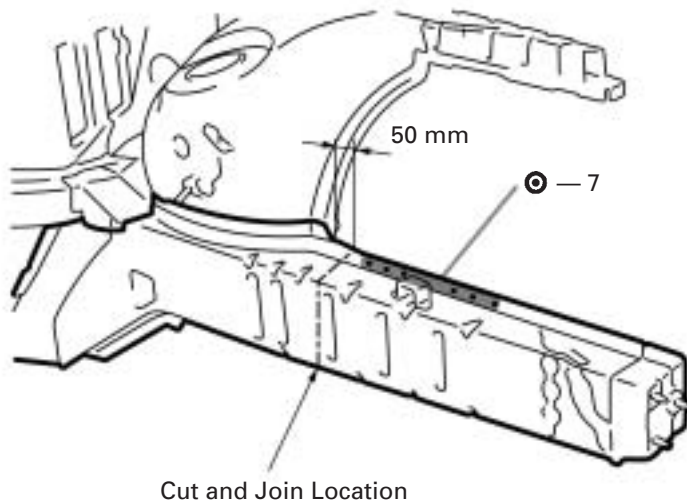
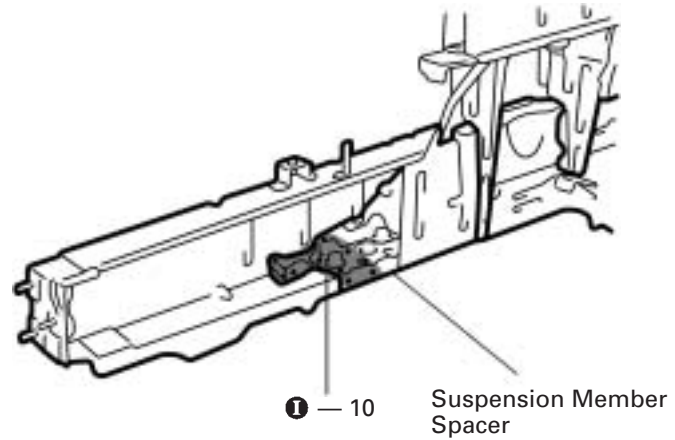
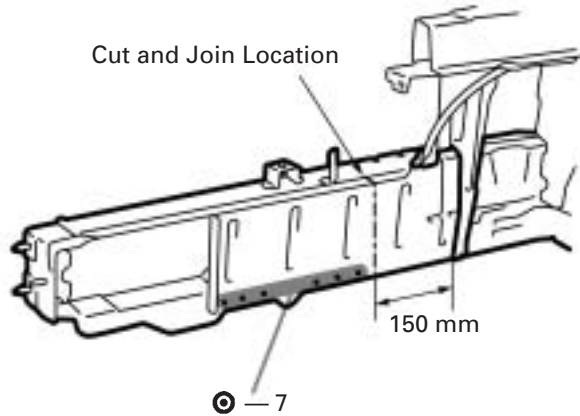

mm	in.
50	1.97
150	5.91

1. Cut and join the parts at the locations as shown above.

3) *Be careful not to damage the suspension member spacer when cutting the member.*

**HINT:**

- 1) *Shift each cut and join locations of outer plate and inner member.*
- 2) *Leaving the suspension member spacer on the vehicle side.*

INSTALLATION

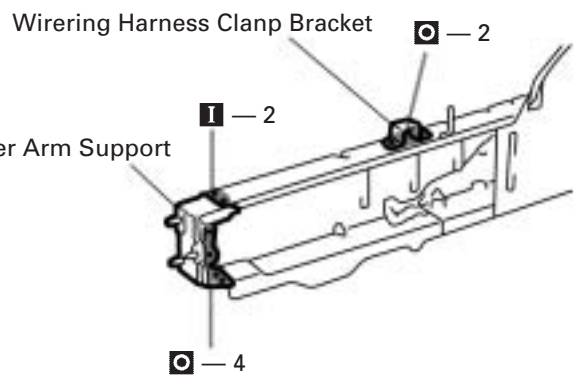
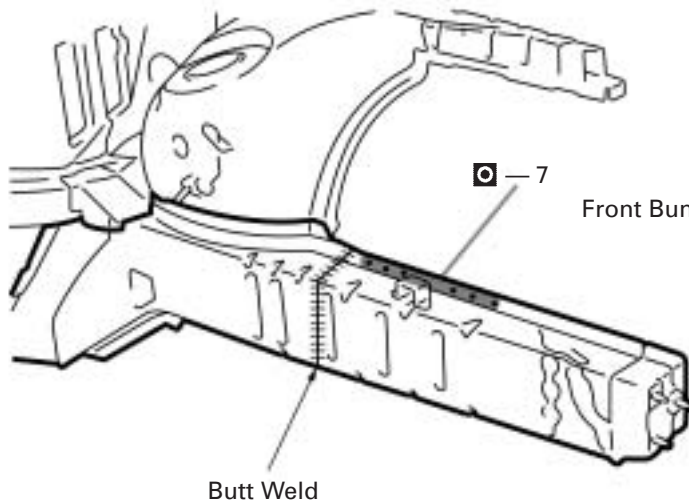
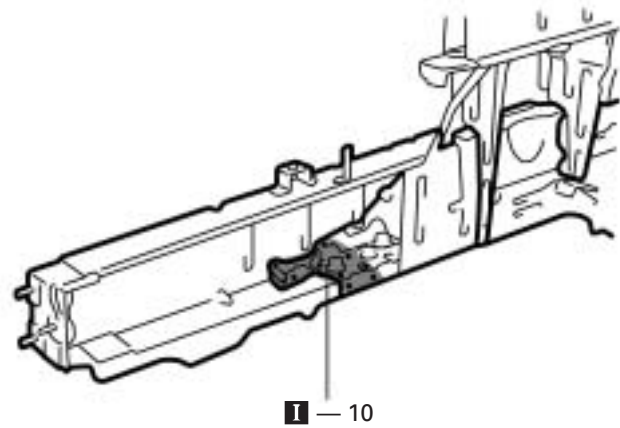
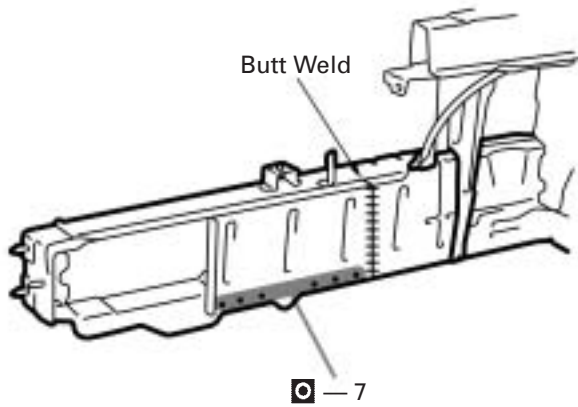

1. Temporarily install the new parts and measure each part in accordance with the body dimension diagram.
2. After butt welding the inner member, install the outer plate.