

# Cool Air Bypass Damper Control Servomotor Circuit (Passenger Side)

## CIRCUIT DESCRIPTION

The cool air bypass servomotor is controlled by the A/C control assembly and moves the cool air bypass damper to the desired position.

## WIRING DIAGRAM

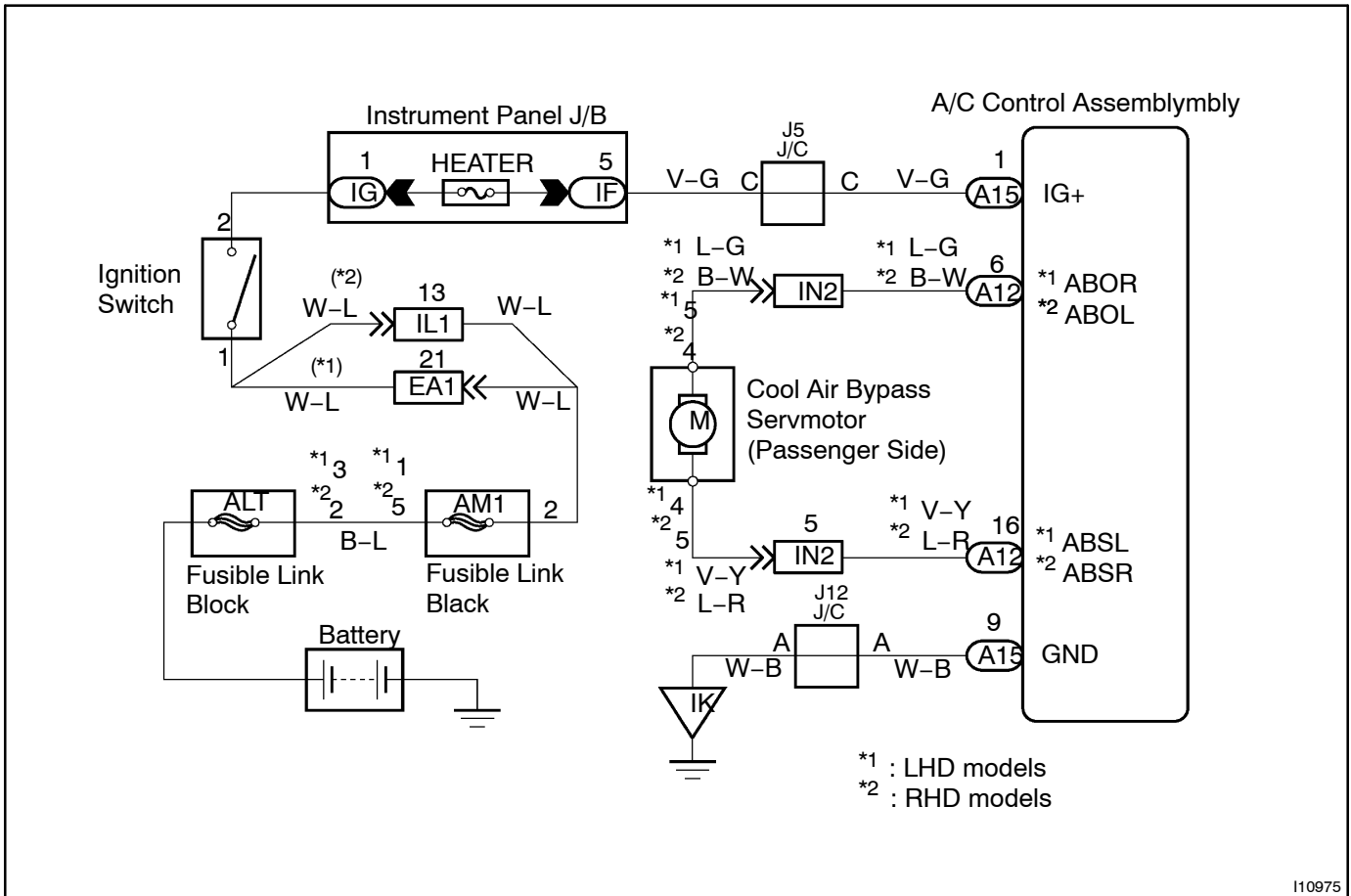

## INSPECTION PROCEDURE

## 1 Actuator check.

**PREPARATION:**

- (a) Set to the actuator check mode (See page DI-768).  
 (b) Press the UP switch and change it to step operation.

**CHECK:**

Push the temperature control switch and check that cool air bypass damper operates with changes in the vent blower output and damper operation noise.

**OK:**

Display Code	Max. Cool Damper
0 - 2	Open
3 - 9	Shut

OK

Proceed to next circuit inspection shown on problem symptoms table (See page DI-780)

NG

## 2 Check cool air bypass damper control servomotor.

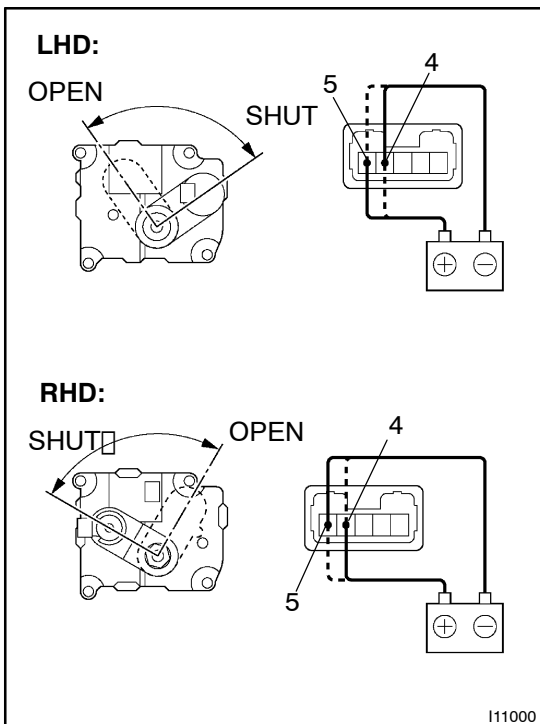

111000

**PREPARATION:**

Remove the cool air bypass damper control servomotor (See page AC-89).

**CHECK:**

Connect positive (+) lead to terminal 4 (5) and negative (-) lead to terminal 5 (4).

( ): RHD models

**OK:**

The lever moves smoothly to SHUT position.

**CHECK:**

Connect negative (-) lead to terminal 4 (5) and positive (+) lead to terminal 5 (4).

( ): RHD models

**OK:**

The lever moves smoothly to OPEN position.

NG

Replace cool air bypass damper control servomotor.

OK

3 Check harness and connector between A/C control assembly and cool air bypass damper control servomotor (See page IN-30).

NG

Repair or replace harness or connector.

OK

Check and replace A/C control assembly.