

HOW TO PROCEED WITH TROUBLESHOOTING

Carry out troubleshooting in accordance with the procedure on the following page. Here, only the basic procedure is shown. Details are provided in Diagnostics section, showing the most effective methods for each circuit. Confirm the troubleshooting procedures for the relevant circuit before beginning troubleshooting of that circuit.

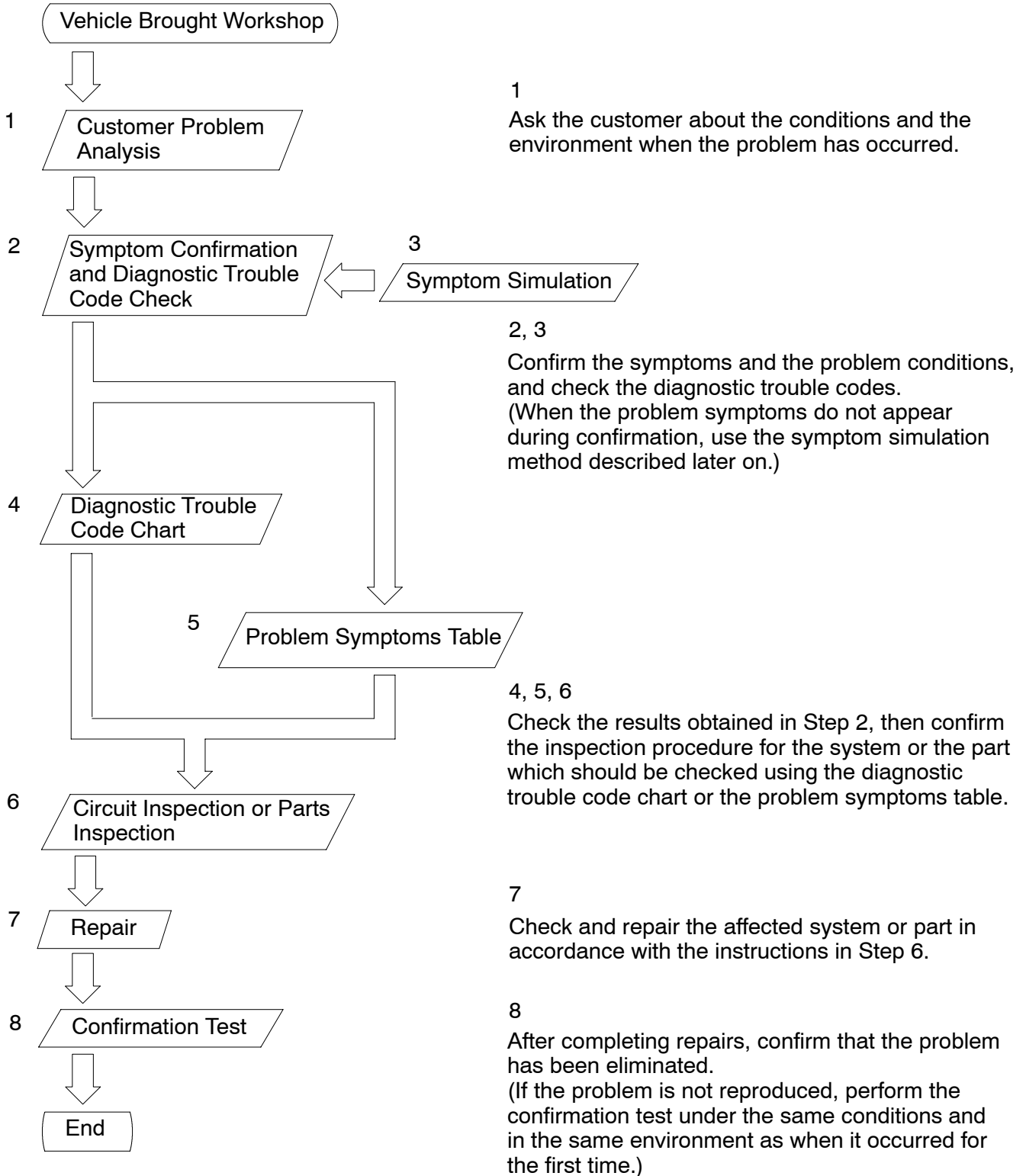

2. SYMPTOM CONFIRMATION AND DIAGNOSTIC TROUBLE CODE CHECK

The diagnostic system in the CENTURY fulfills various functions. The first function is the Diagnostic Trouble Code Check in which a malfunction in the signal circuits to the ECU is stored in code in the ECU memory at the time of occurrence, to be output by the technician during troubleshooting. Another function is the Input Signal Check which checks if the signals from various switches are sent to the ECU correctly.

By using these check functions, the problem areas can be narrowed down quickly and troubleshooting can be performed effectively. Diagnostic functions are incorporated in the following systems in the CENTURY.

System	Diagnostic Trouble Code Check	Input Signal Check (Sensor Check)	Diagnostic Test Mode (Active Test)
ABS & BA & TRC & VSC System	○	○	○

In diagnostic trouble code check, it is very important to determine whether the problem indicated by the diagnostic trouble code is still occurring or occurred in the past but returned to normal at present. In addition, it must be checked in the problem symptom check whether the malfunction indicated by the diagnostic trouble code is directly related to the problem symptom or not. For this reason, the diagnostic trouble codes should be checked before and after the symptom confirmation to determine the current conditions, as shown in the table below. If this is not done, it may, depending on the case, result in unnecessary troubleshooting for normally operating systems, thus making it more difficult to locate the problem, or in repairs not pertinent to the problem. Therefore, always follow the procedure in correct order and perform the diagnostic trouble code check.

DIAGNOSTIC TROUBLE CODE CHECK PROCEDURE

Diagnostic Trouble Code Check (Make a note of and then clear)	Confirmation of Symptoms	Diagnostic Trouble Code Check	Problem Condition
Diagnostic Trouble Code Display	Problem symptoms exist	Same diagnostic trouble code is displayed	Problem is still occurring in the diagnostic circuit
	➡	Normal code is displayed	The problem is still occurring in a place other than in the diagnostic circuit. (The diagnostic trouble code displayed first is either for a past problem or it is a secondary problem.)
Normal Code Display	No problem symptoms exist		The problem occurred in the diagnostic circuit in the past.
	Problem symptoms exist	Normal code is displayed	The problem is still occurring in a place other than in the diagnostic circuit.
	No problem symptoms exist	Normal code is displayed	The problem occurred in a place other than in the diagnostic circuit in the past.

Taking into account the points on the previous page, a flow chart showing how to proceed with troubleshooting using the diagnostic trouble code check is shown below. This flow chart shows how to utilize the diagnostic trouble code check effectively, then by carefully checking the results, indicates how to proceed either to diagnostic trouble code troubleshooting or to troubleshooting of problem symptoms table.

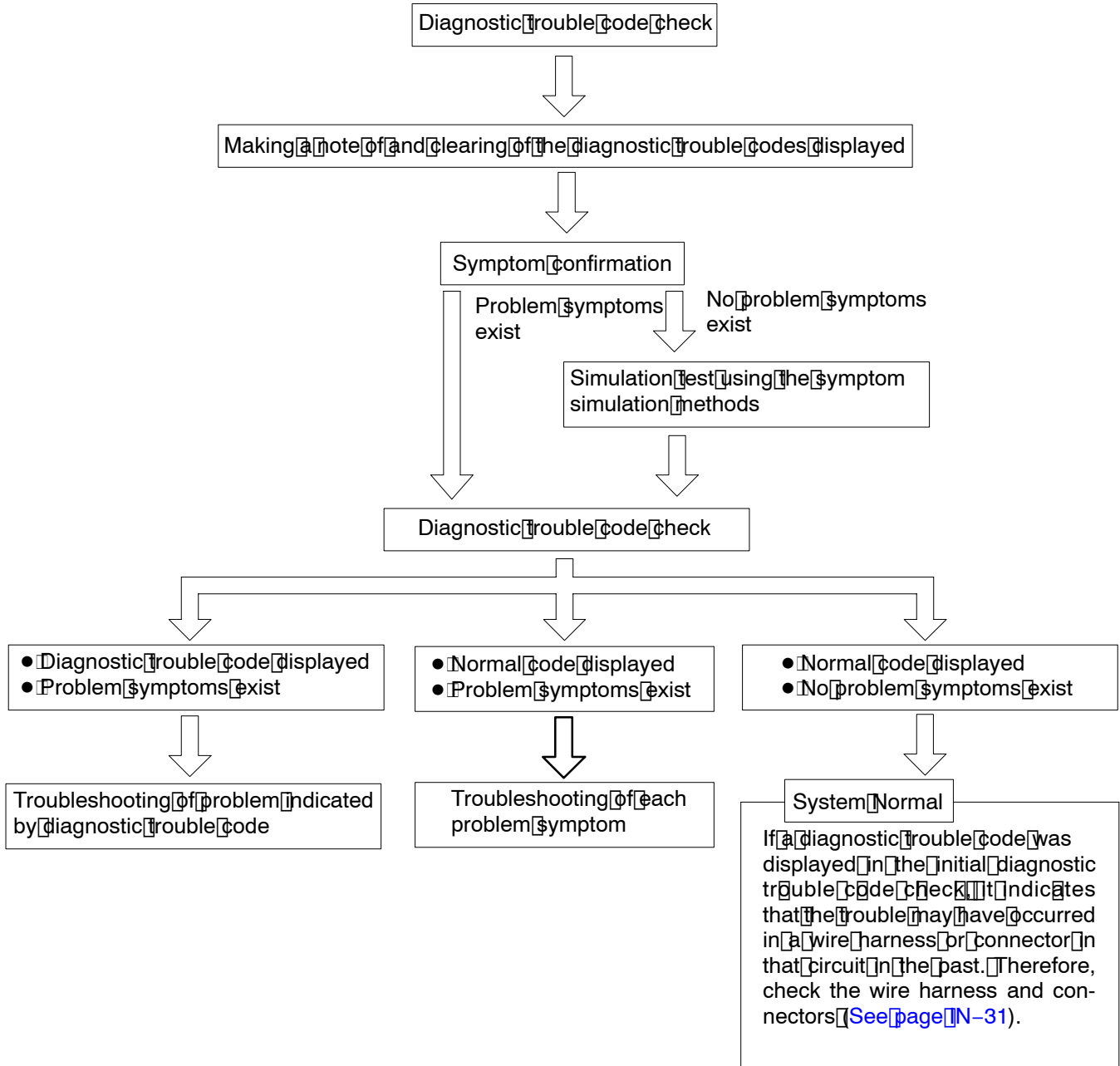

3. SYMPTOM SIMULATION

The most difficult case in troubleshooting is when there are no problem symptoms occurring. In such cases, a thorough customer problem analysis must be carried out, then simulate the same or similar conditions and environment in which the problem occurred in the customer's vehicle. No matter how much experience a technician has, or how skilled he may be, if he proceeds to troubleshoot without confirming the problem symptoms he will tend to overlook something important in the repair operation and make a wrong guess somewhere, which will only lead to a standstill. For example, for a problem which only occurs when the engine is cold, or for a problem which occurs due to vibration caused by the road during driving, etc., the problem can never be determined so long as the symptoms are confirmed with the engine hot condition or the vehicle at a standstill. Since vibration, heat or water penetration (moisture) is likely cause for problem which is difficult to reproduce, the symptom simulation tests introduced here are effective measures in that the external causes are applied to the vehicle in a stopped condition.

Important Points in the Symptom Simulation Test:

In the symptom simulation test, the problem symptoms should of course be confirmed, but the problem area or parts must also be found out. To do this, narrow down the possible problem circuits according to the symptoms before starting this test and connect a tester beforehand. After that, carry out the symptom simulation test, judging whether the circuit being tested is defective or normal and also confirming the problem symptoms at the same time. Refer to the problem symptoms table for each system to narrow down the possible causes of the symptom.

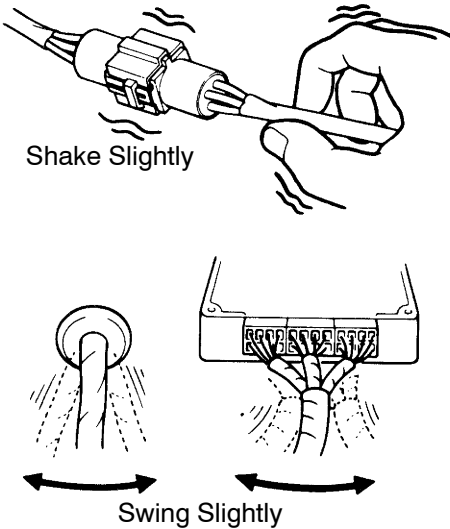
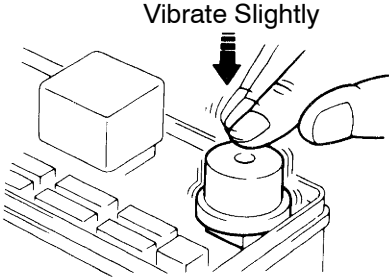
<p>1</p>	<p>VIBRATION METHOD: When vibration seems to be the major cause.</p>
<p>CONNECTORS Slightly shake the connector vertically and horizontally.</p> <p>WIRE HARNESS Slightly shake the wire harness vertically and horizontally. The connector joint, fulcrum of the vibration, and body through portion are the major areas to be checked thoroughly.</p>	 <p>Shake Slightly</p> <p>Swing Slightly</p> <p>F12331 F12332</p>
<p>PARTS AND SENSOR Apply slight vibration with a finger to the part of the sensor considered to be the problem cause and check if the malfunction occurs.</p> <p>HINT: Applying strong vibration to relays may result in open relays.</p>	 <p>Vibrate Slightly</p> <p>F12330</p>

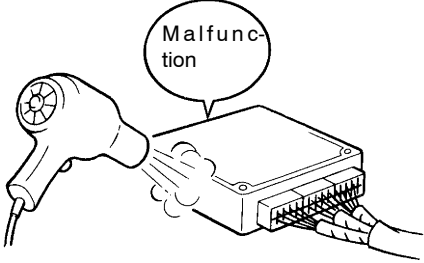
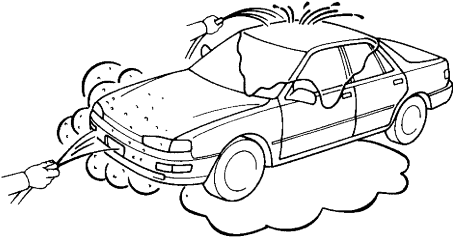
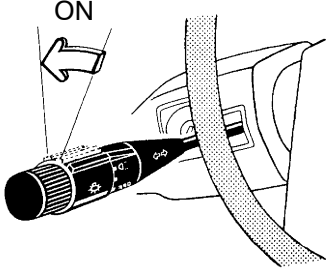
<p>2</p>	<p>HEAT METHOD: When the problem seems to occur when the suspect area is heated.</p>
<p>Heat the component that is the likely cause of the malfunction with a hair dryer or similar object. Check to see if the malfunction occurs.</p> <p>NOTICE:</p> <p>(1) Do not heat to more than 60 °C (140 °F). (Temperature is limited not to damage the components.)</p> <p>(2) Do not apply heat directly to parts in the ECU.</p>	 <p>F12334</p>
<p>3</p>	<p>WATER SPRINKLING METHOD: When the malfunction seems to occur on a rainy day or in a high-humidity condition.</p>
<p>Sprinkle water onto the vehicle and check to see if the malfunction occurs.</p> <p>NOTICE:</p> <p>(1) Never sprinkle water directly into the engine compartment, but indirectly change the temperature and humidity by applying water spray onto the radiator front surface.</p> <p>(2) Never apply water directly onto the electronic components.</p> <p>(Service hint) If a vehicle is subject to water leakage, the leaked water may contaminate the ECU. When testing a vehicle with a water leakage problem, special caution must be taken.</p>	 <p>F16649</p>
<p>4</p>	<p>OTHER: When a malfunction seems to occur when electrical load is excessive.</p>
<p>Turn on all electrical loads including the heater blower, head lights, rear window defogger, etc. and check to see if the malfunction occurs.</p>	 <p>F12336</p>

4. DIAGNOSTIC TROUBLE CODE CHART

The inspection procedure is shown in the table below. This table permits efficient and accurate troubleshooting using the diagnostic trouble codes displayed in the diagnostic trouble code check. Proceed with troubleshooting in accordance with the inspection procedure given in the diagnostic chart corresponding to the diagnostic trouble codes displayed. The engine diagnostic trouble code chart is shown below as an example.

- DTC No.
Indicates the diagnostic trouble code.
- Page or Instructions
Indicates the page where the inspection procedure for each circuit is to be found, or gives instructions for checking and repairs.
- Trouble Area
Indicates the suspect area of the problem.

- Detection Item
Indicates the system of the problem or contents of the problem.

DIAGNOSTIC TROUBLE CODE CHART
 If a malfunction code is displayed during the DTC check, check the circuit for that code listed in the table below. (Proceed to the page given for that circuit).

DTC No. (See page)	Detection Item	Trouble Area	SRS Warming Light
11 (DI-14)	● Short in D squib circuit (to ground)	● Steering wheel pad (squib) ● Spiral cable ● Airbag sensor assembly ● Wire harness	ON
12 (DI-19)	● Short in D squib circuit (to B+)	● Steering wheel pad (squib) ● Spiral cable ● Airbag sensor assembly ● Wire harness	ON
13 (DI-23)	● Short in D squib circuit	● Steering wheel pad (squib) ● Spiral cable ● Airbag sensor assembly ● Wire harness	ON
14 (DI-27)	● Open in D squib circuit	● Steering wheel pad (squib) ● Spiral cable ● Airbag sensor assembly ● Wire harness	ON
15 (DI-27)	● Front airbag sensor assembly (RH) malfunction	● Front airbag sensor assembly (RH) ● Wire harness	ON
	● Front airbag sensor assembly (LH) malfunction	● Front airbag sensor assembly (LH) ● Wire harness	
	● Airbag sensor assembly malfunction	● Airbag sensor assembly	

5. PROBLEM SYMPTOMS TABLE

The suspected circuits or parts for each problem symptom are shown in the table below. Use this table to troubleshoot the problem when a "Normal" code is displayed in the diagnostic trouble code check but the problem is still occurring. Numbers in the table indicate the inspection order in which the circuits or parts should be checked.

HINT:

When the problem is not detected by the diagnostic system even though the problem symptom is present, it is considered that the problem is occurring outside the detection range of the diagnostic system, or that the problem is occurring in a system other than the diagnostic system.

● Page
Indicates the page where the flow chart for each circuit is located.

● Circuit Inspection, Inspection Order
Indicates the circuit which needs to be checked for each problem symptom. Check in the order indicated by the numbers.

● Problem Symptom

● Circuit or Part Name
Indicates the circuit or part which needs to be checked.

PROBLEM SYMPTOMS TABLE
Proceed with troubleshooting of each circuit in the table below.

Symptom	Suspect Area	See page
<ul style="list-style-type: none"> ● With the ignition switch in the ACC or ON position, the SRS warning light sometimes lights up after approx. 6 seconds have elapsed. ● SRS warning light is always lit up even when ignition switch is in the LOCK position 	<ul style="list-style-type: none"> ● SRS warning light circuit (Always lights up when ignition switch is in LOCK position.) 	DI-91
<ul style="list-style-type: none"> ● With the ignition switch in the ACC or ON position, the SRS warning light does not light up. 	<ul style="list-style-type: none"> ● SRS warning light circuit (Does not light up when ignition switch is turned to ACC or ON.) 	DI-93
<ul style="list-style-type: none"> ● DTC is not displayed. ● SRS warning light is always lit up at the time of DTC check procedure. ● DTC is displayed without Tc and E1 terminal connection. 	<ul style="list-style-type: none"> ● Tc terminal circuit 	DI-97

6. CIRCUIT INSPECTION

How to read and use each page is shown below.

● Diagnostic Trouble Code No. and Detection Item

● Circuit Description
The major role and operation, etc. of the circuit and its component parts are explained.

DTC	13	Short in D Squib Circuit
------------	-----------	---------------------------------

CIRCUIT DESCRIPTION

The D squib circuit consists of the airbag sensor assembly, spiral cable and steering wheel pad.
It causes the airbag to deploy when the airbag deployment conditions are satisfied.
For details of the function of each components, see OPERATION on page RS-2.
DTC 13 is recorded when a short is detected in the D squib circuit.

DTC No.	DTC Detecting Condition	Trouble Area
13	<ul style="list-style-type: none"> • Short circuit between D+ wire harness and D- wire harness of squib • D squib malfunction • Spiral cable malfunction • Airbag sensor assembly malfunction 	<ul style="list-style-type: none"> • Steering wheel pad (D squib) • Spiral cable • Airbag sensor assembly • Wire harness

● Indicates the diagnostic trouble code, diagnostic trouble code set parameter and suspect area of the problem.

WIRING DIAGRAM

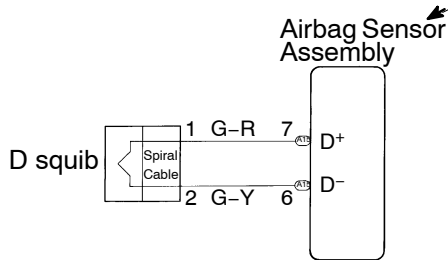

R16015

● Wiring Diagram
This shows a wiring diagram of the circuit. Use this diagram together with ELECTRICAL WIRING DIAGRAM to thoroughly understand the circuit.
Wire colors are indicated by an alphabetical code. B = Black, L = Blue, R = Red, BR = Brown, LG = Light Green, V = Violet, G = Green, O = Orange, W = White, GR = Gray, P = Pink, Y = Yellow, SB = Sky Blue
The first letter indicates the basic wire color and the second letter indicates the color of the stripe.

- Indicates the position of the ignition switch during the check.



- Inspection Procedure**
Use the inspection procedure to determine if the circuit is normal or abnormal, and if it is abnormal, use it to determine whether the problem is located in the sensors, actuators, wire harness or ECU.

INSPECTION PROCEDURE

2 Check voltage at IG2 and ACC of airbag sensor assembly.

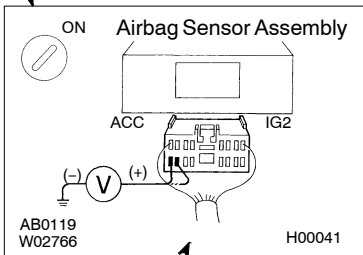

PREPARATION:

Turn ignition switch ON.

CHECK:

Measure voltage between terminals IG2 and ACC of airbag sensor assembly and body ground.

OK:

Voltage: Below 16 V

OK

NG

Check battery and charging system. (See charging system section)

- Indicates the place to check the voltage or resistance.
- Indicates the connector position to be checked, from the front or back side.

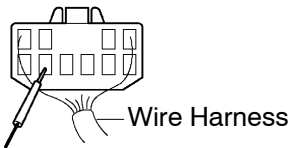

Check from the connector back side. (with harness)



Check from the connector front side. (without harness)
In this case, care must be taken not to bend the terminals.

- Indicates the condition of the connector of ECU during the check.

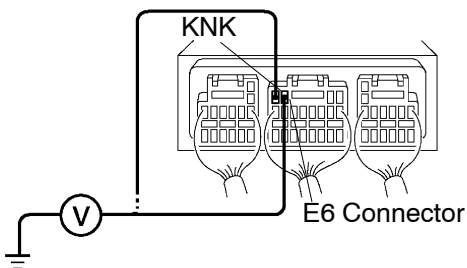

Connector being checked is connected.

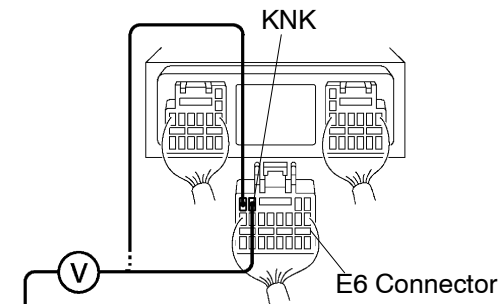

Connector being checked is disconnected.