

TIMING CHAIN COMPONENTS

EM10L-01

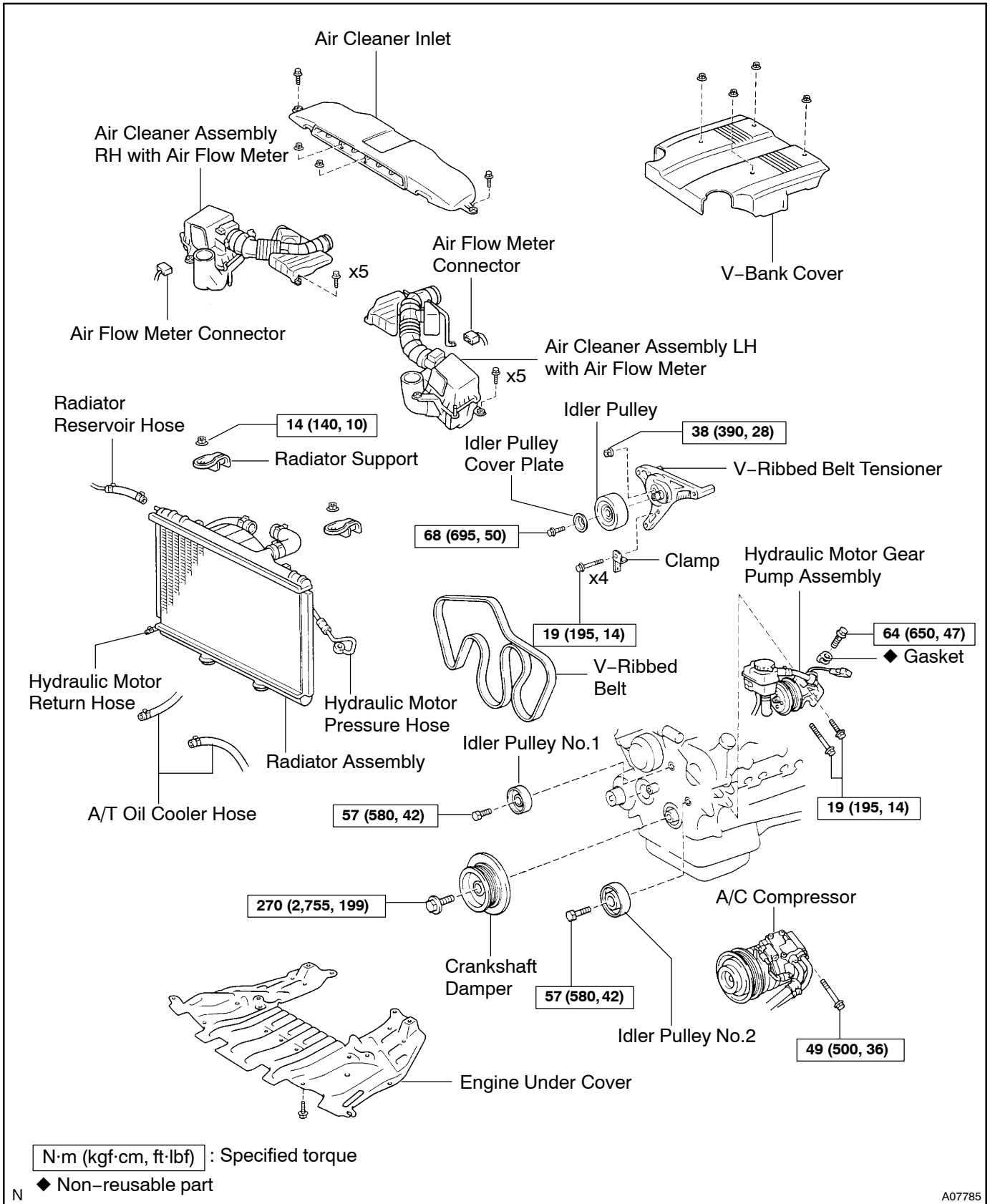

N

A07785

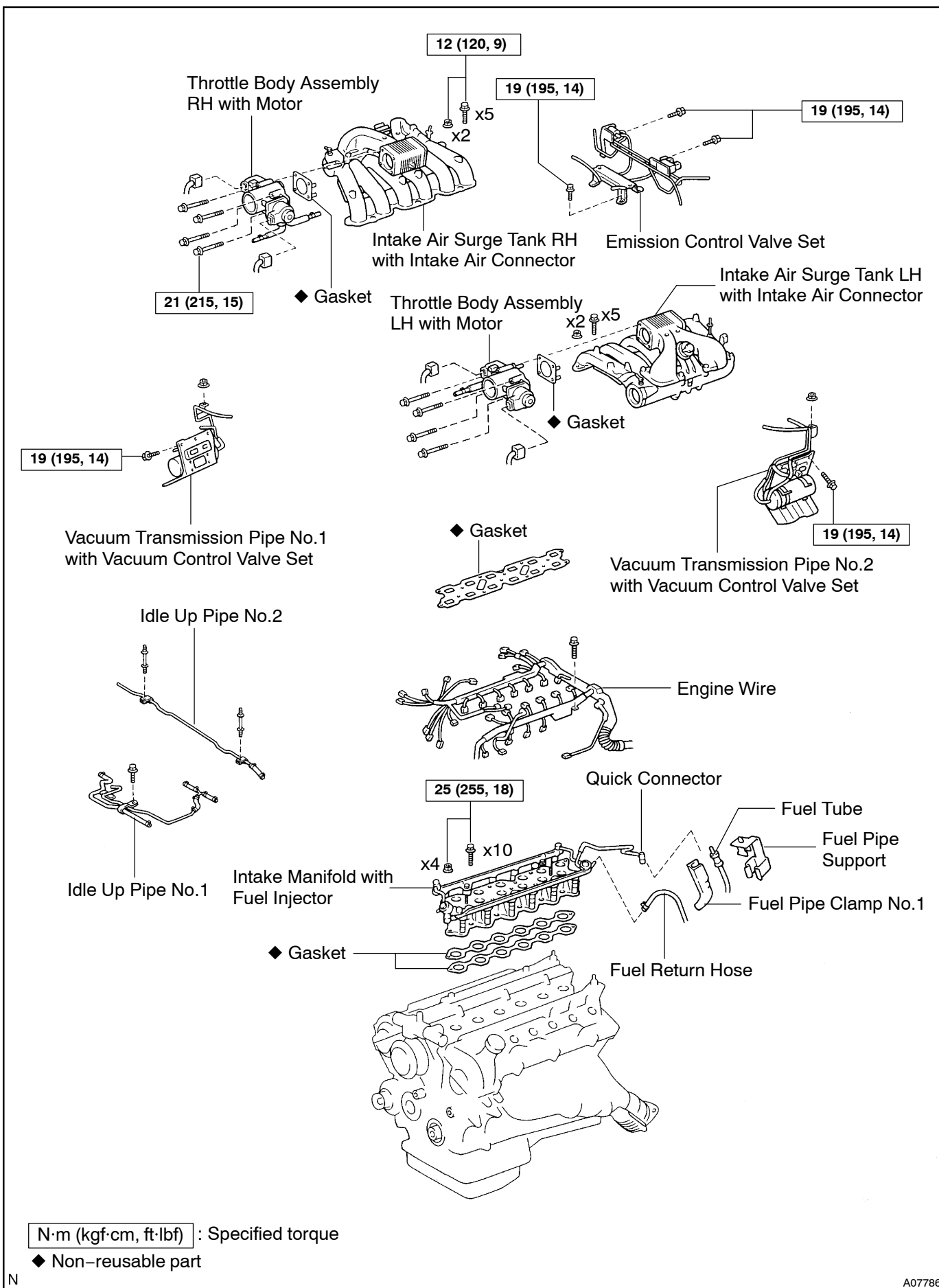

N·m (kgf·cm, ft·lbf) : Specified torque

◆ Non-reusable part

