

CIRCUIT

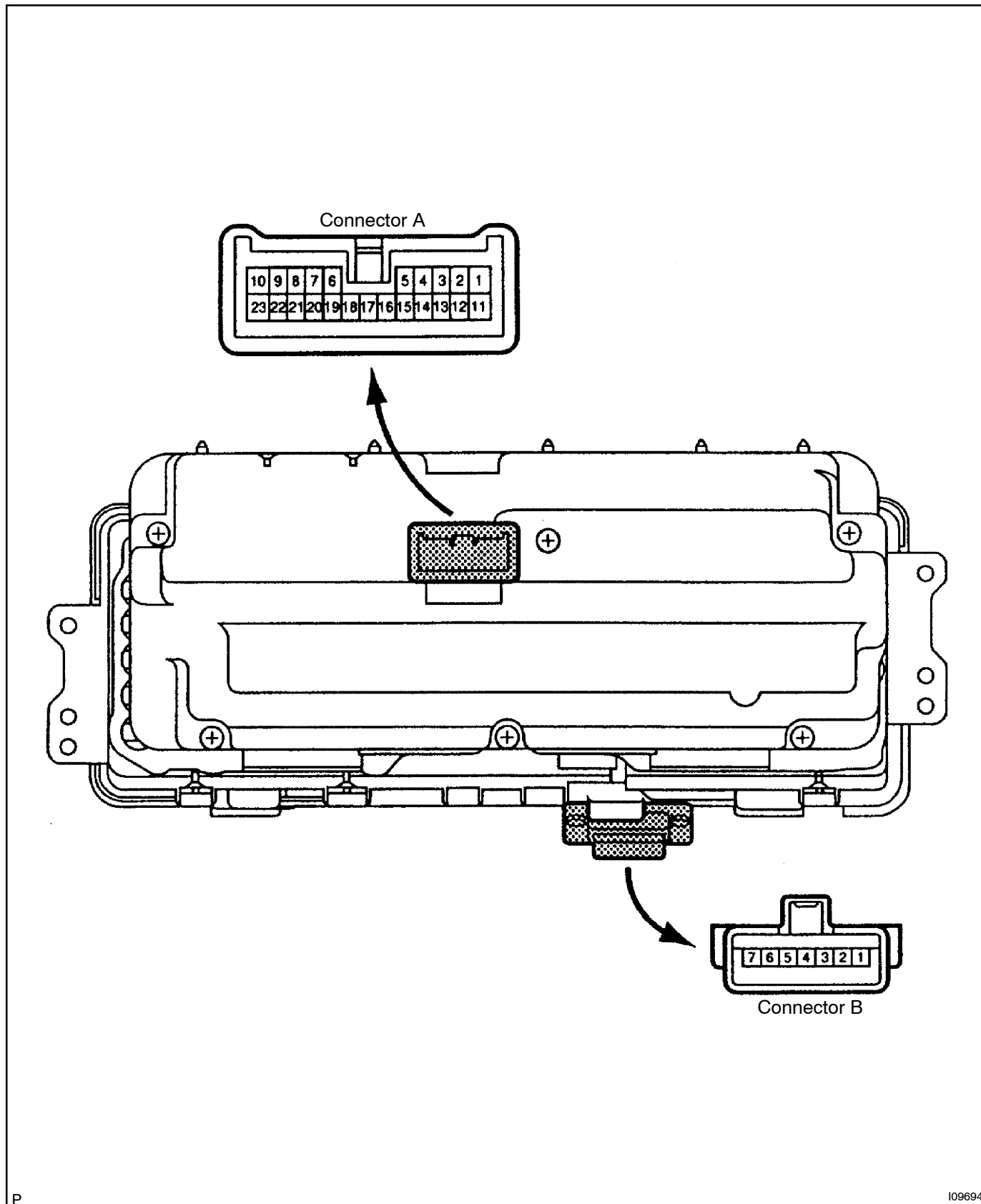

P

109694

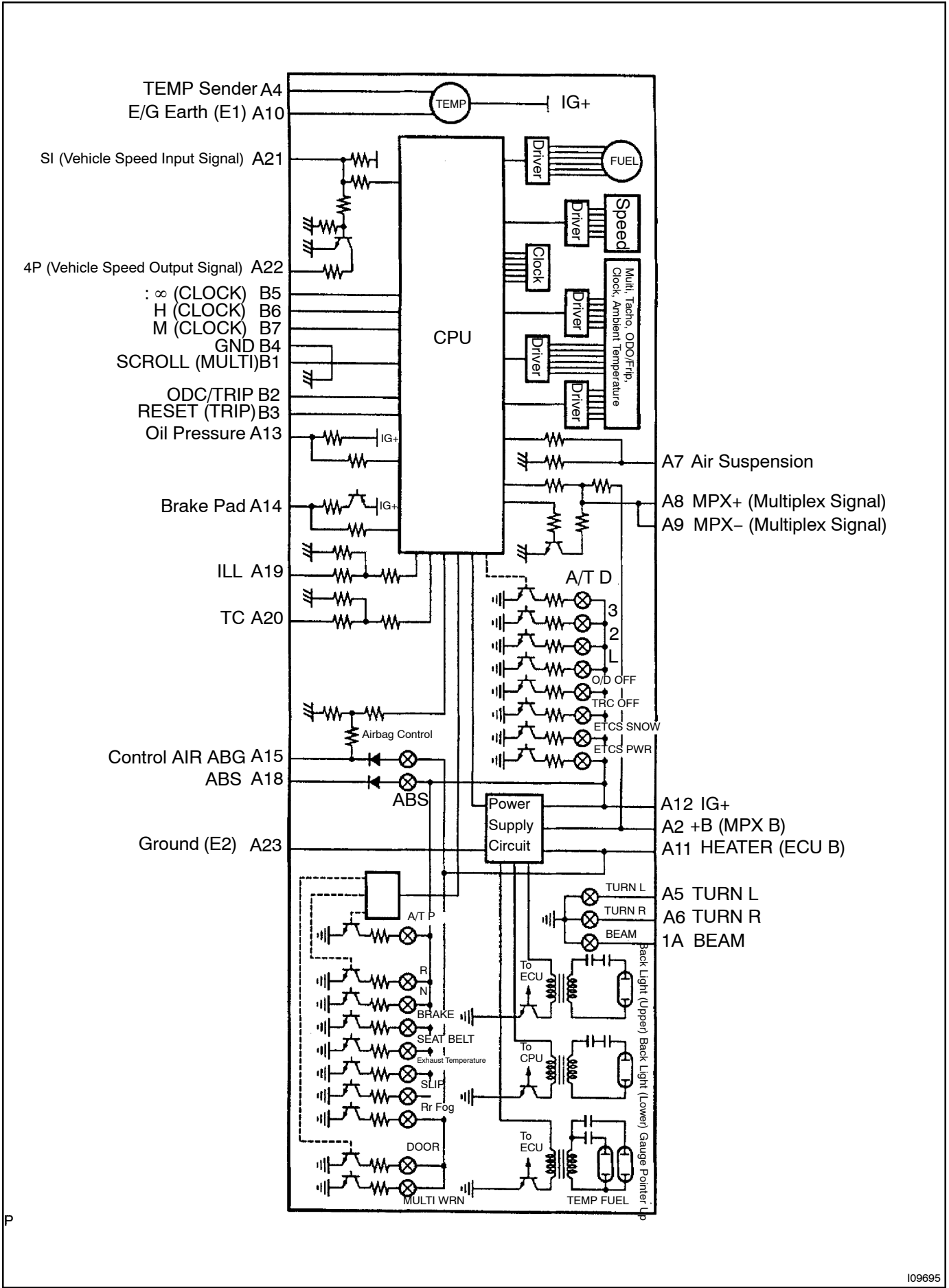

Meter Connector A

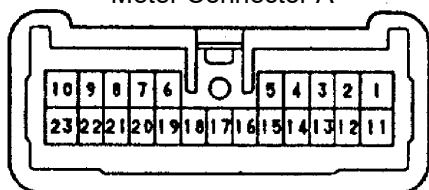

Body Side Connector of Light Control Rheostat

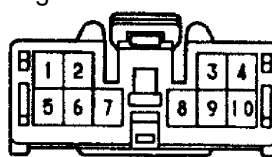

Meter Connector B

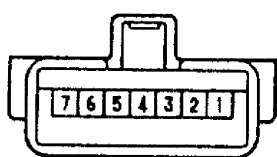

Trip Switch Body Side Connector

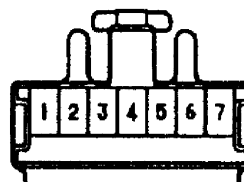

ECU Side Connector of Engine and ECT ECU (LH)

Connector A

Connector B

Connector C

Connector D

Connector E

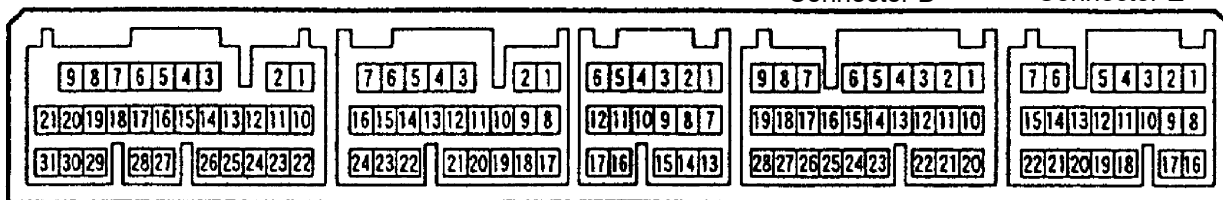

Meter Circuit Plate

