

<b>DTC</b>	<b>B0110/43</b>	<b>Short in Front Side Squib (RH) Circuit</b>
------------	-----------------	-----------------------------------------------

**CIRCUIT DESCRIPTION**

The front side squib (RH) circuit consists of the airbag sensor assembly and front side airbag assembly (RH). It causes the SRS to deploy when the SRS deployment conditions are satisfied.

For details of the function of each component, see OPERATION on page RS-3.

DTC B0110/43 is recorded when a short is detected in the front side squib (RH) circuit.

DTC No.	DTC Detecting Condition	Trouble Area
B0110/43	<ul style="list-style-type: none"> <li>• Short circuit between FR+ wire harness and FR- wire harness of squib</li> <li>• Front side squib (RH) malfunction</li> <li>• Airbag sensor assembly malfunction</li> </ul>	<ul style="list-style-type: none"> <li>• Front side airbag assembly (RH)</li> <li>• Airbag sensor assembly</li> <li>• Wire harness</li> </ul>

**WIRING DIAGRAM**

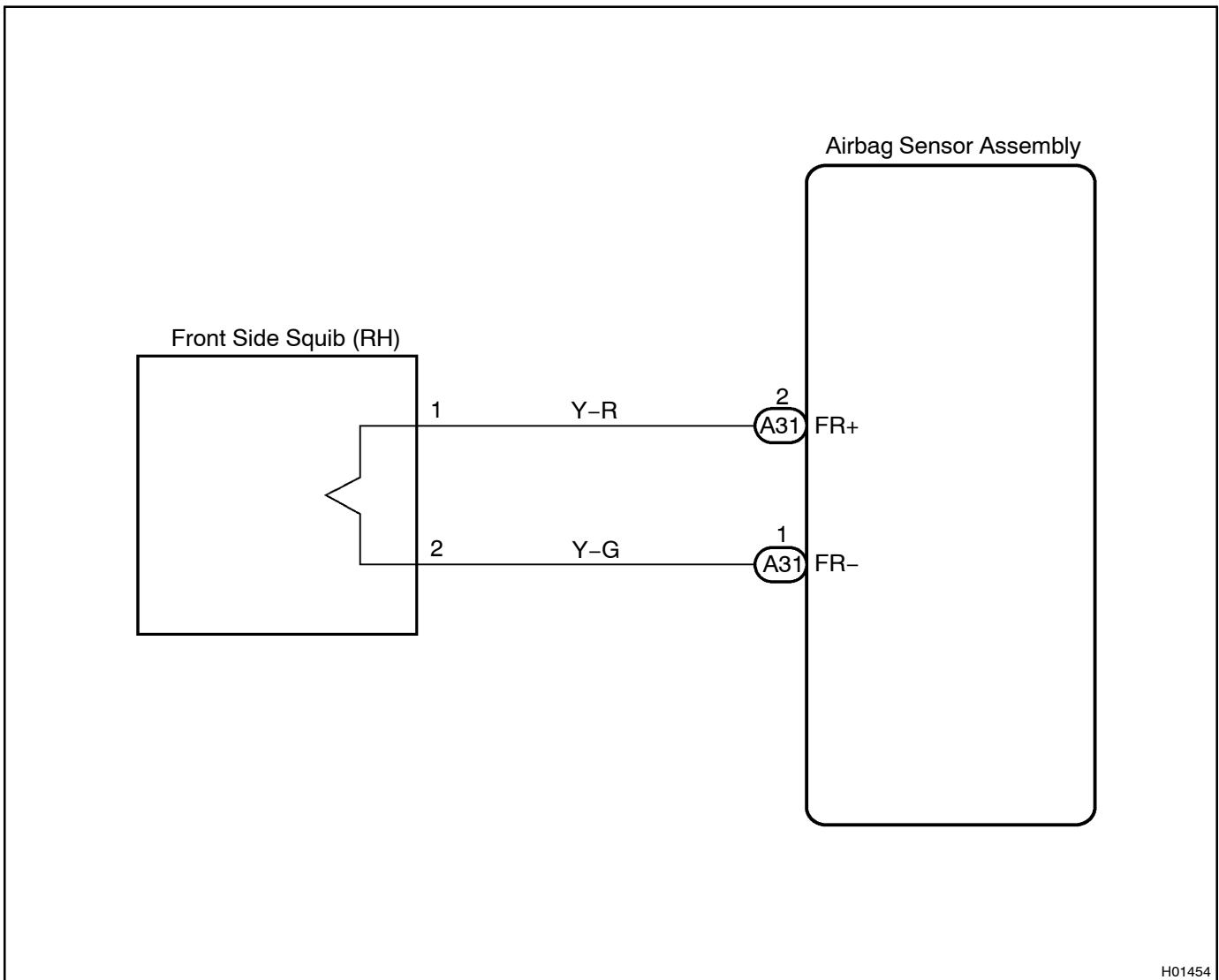

## INSPECTION PROCEDURE

1 Prepare for inspection. (See step 1 on page DI-368)

2 Check front side squib (RH) circuit.

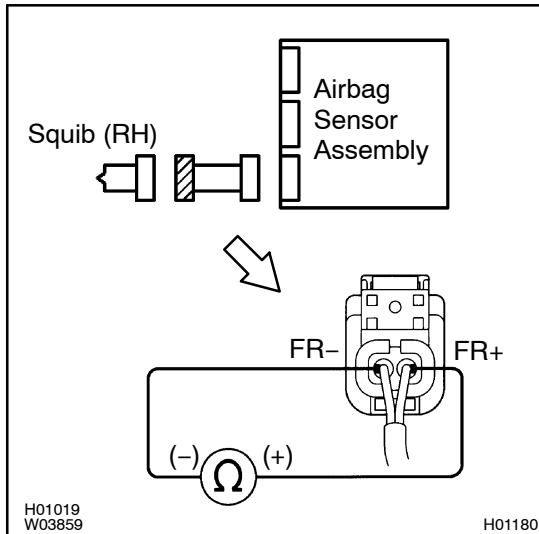
**PREPARATION:**

Release the airbag activation prevention mechanism of the connector (on the airbag sensor assembly side) between the airbag sensor assembly and the front side airbag assembly (RH). (See page DI-229)

**CHECK:**

For the connector (on the front side airbag assembly side) between the front side airbag assembly (RH) and the airbag sensor assembly, measure the resistance between FR+ and FR-.

**OK:**

**Resistance: 1 MΩ or Higher**

**NG**

**Repair or replace harness or connector between front side airbag assembly (RH) and airbag sensor assembly.**

**OK**

### 3 Check airbag sensor assembly.

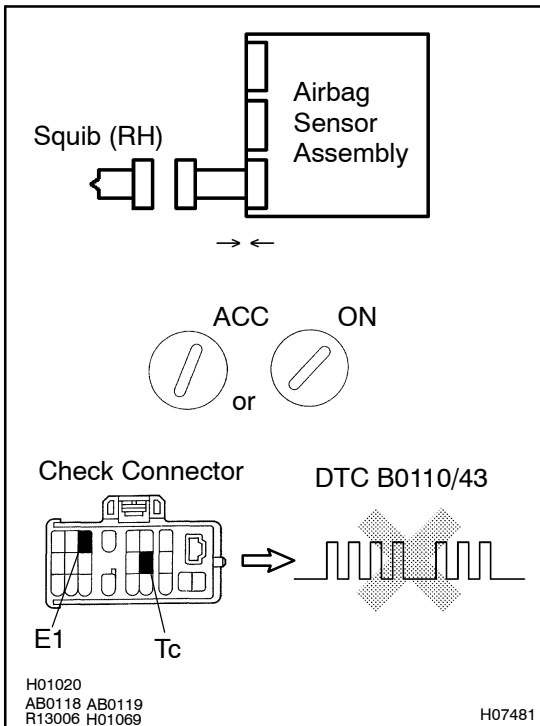

#### PREPARATION:

- Connect the connector to the airbag sensor assembly.
- Connect negative (-) terminal cable to the battery, and wait at least for 2 seconds.

#### CHECK:

- Turn ignition switch to ACC or ON and wait at least for 20 seconds.
- Clear DTC stored in memory. (See page DI-229)
- Turn ignition switch to LOCK, and wait at least for 20 seconds.
- Turn ignition switch to ACC or ON, and wait at least for 20 seconds.
- Check DTC. (See page DI-229)

#### OK:

**DTC B0110/43 is not output.**

#### HINT:

Codes other than code B0110/43 may be output at this time, but they are not relevant to this check.

**NG**

**Replace airbag sensor assembly.**

**OK**

#### 4 Check front side squib (RH).

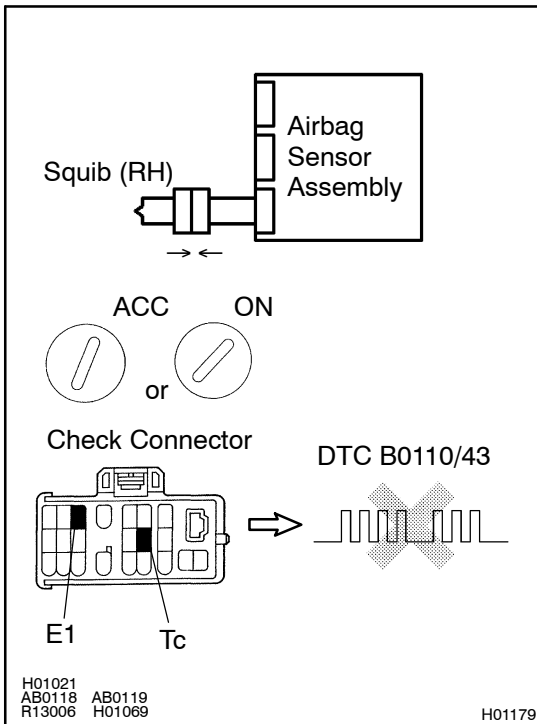

#### PREPARATION:

- Turn ignition switch to LOCK.
- Disconnect negative (-) terminal cable from the battery, and wait at least for 90 seconds.
- Connect the front side airbag assembly (RH) connector.
- Connect negative (-) terminal cable to the battery, and wait at least for 2 seconds.

#### CHECK:

- Turn ignition switch to LOCK, and wait at least for 20 seconds.
- Turn ignition switch to ACC or ON, and wait at least for 20 seconds.
- Clear DTC stored in memory. (See page DI-229)
- Turn ignition switch to LOCK, and wait at least for 20 seconds.
- Turn ignition switch to ACC or ON, and wait at least for 20 seconds.
- Check DTC. (See page DI-229)

#### OK:

**DTC B0110/43 is not output.**

#### HINT:

Codes other than code B0110/43 may be output at this time, but they are not relevant to this check.

**NG**

**Replace front side airbag assembly (RH).**

**OK**

**From the results of the above inspection, the malfunctioning part can now be considered normal. To make sure of this, use the simulation method to check.**