

DTC	Always ON	Malfunction in ECU ABS Warning Light Circuit
------------	------------------	---

CIRCUIT DESCRIPTION

DTC No.	DTC Detecting Condition	Trouble Area
Always ON	Malfunction in skid control ECU	<ul style="list-style-type: none"> • Power source circuit • ABS warning light circuit • Skid control ECU

HINT:

In some cases the hand-held tester cannot be used when the skid control ECU is abnormal.

WIRING DIAGRAM

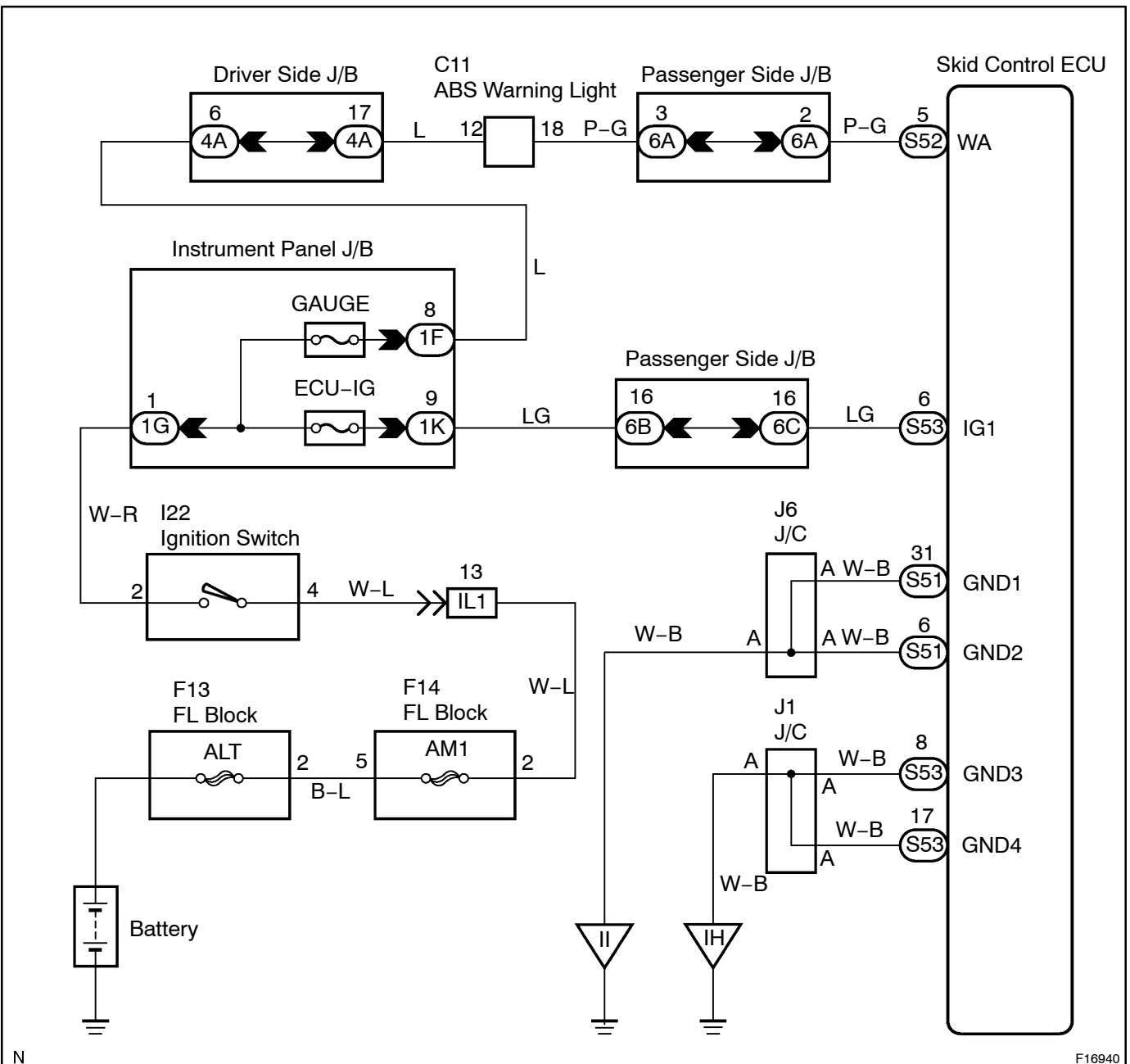

N

F16940

INSPECTION PROCEDURE

1 Is DTC output?

Check DTC on page DI-3.

YES

Repair circuit indicated by the code output.

NO

2 Check that the skid control ECU connectors are securely connected to the skid control ECU.

NO

Connect the connector to the skid control ECU.

YES

3 Check voltage of the ECU IG power source.

In case of using the hand-held tester:

PREPARATION:

- Connect the hand-held tester to the DLC3.
- Turn the ignition switch to ON and turn the hand-held tester main switch to ON.
- Select the DATALIST mode on the hand-held tester.

CHECK:

Check the voltage condition output from the ECU observed in the hand-held tester.

OK:

"Normal" is displayed.

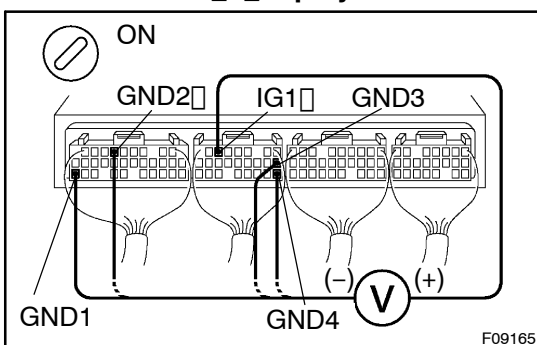

In case of not using the hand-held tester:

PREPARATION:

Remove the skid control ECU with the connectors still connected to it.

CHECK:

- Turn the ignition switch to ON.
- Measure voltage between the terminals IG1 and GND of the skid control ECU.

OK:

Voltage: 10 - 14 V

OK

Check and replace skid control ECU.

NG

4	Check battery positive voltage.
---	--

CHECK:

Check the battery positive voltage.

OK:

Voltage: 10 – 14 V

NG

Check and repair the charging system.

OK

5	Check operation of the ABS warning light.
---	--

In case of using the hand-held tester:**PREPARATION:**

- (a) Connect the hand-held tester to the DLC3.
- (b) Turn the ignition switch to ON and turn the hand-held tester main switch to ON.
- (c) Select the ACTIVE TEST mode on the hand-held tester.

CHECK:

Check that "ON" and "OFF" of the ABS warning light can be shown on the combination meter by the hand-held tester.

In case of not using the hand-held tester:**PREPARATION:**

- (a) Turn the ignition switch OFF.
- (b) Disconnect the connector from the skid control ECU.
- (c) Turn the ignition switch to ON.

CHECK:

Check that the ABS warning light lights up.

OK

Check and replace skid control ECU.

NG

6 Check for short circuit in harness and connector between terminal skid control ECU and combination meter (See page IN-31).

NG

Repair or replace harness or connector.

OK

Repair or replace combination meter.