

## INSTALLATION

### 1. INSTALL PROPELLER SHAFT

- (a) Apply grease to the flexible coupling centering bushings.

**Grease:**

**Molybdenum disulphide lithium base, NLGI No. 2**

- (b) Install the propeller shaft from the vehicle's rear and connect the transmission and differential.

**NOTICE:**

**Support the center support bearing by hand so that the transmission and intermediate shaft, and propeller shaft and differential, remain in a straight line.**

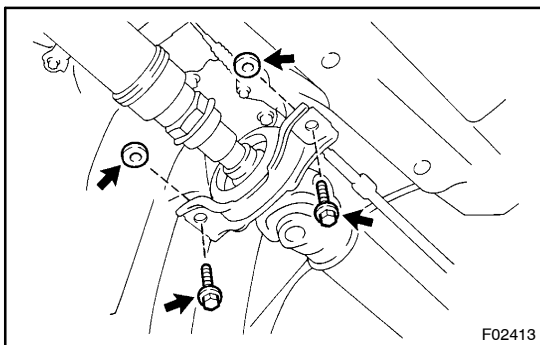

- (c) Temporarily install the 2 center support bearing set bolts with the adjusting washers.

**HINT:**

Use the adjusting washers which were removed.

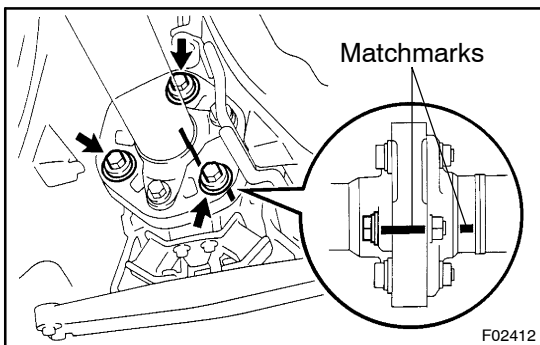

- (d) Align the matchmarks and connect the propeller shaft to the transmission/differential.

- (e) Install and torque the 3 bolts, washers and nuts.

**Torque: 79 N·m (805 kgf·cm, 58 ft·lbf)**

**NOTICE:**

**The bolts should be installed from the propeller shaft side.**

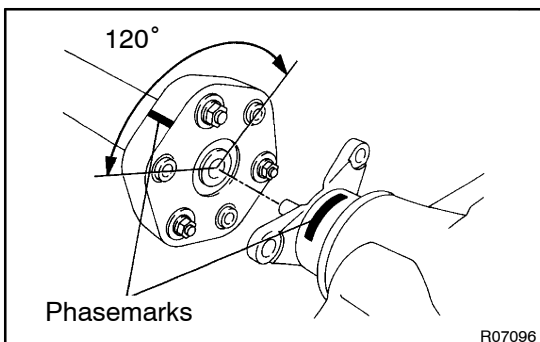

- (f) If using a new propeller shaft (w/ Phasemarks):  
Install the propeller shaft phasemarks and differential/transmission phasemarks so that their respective alignment phasemarks match.

If the propeller shaft phasemarks and differential/transmission phasemarks do not align, install the propeller shaft and differential alignment phasemarks as close together as possible.

- (g) If using a new propeller shaft (w/o Phasemarks):  
Install the propeller shaft.

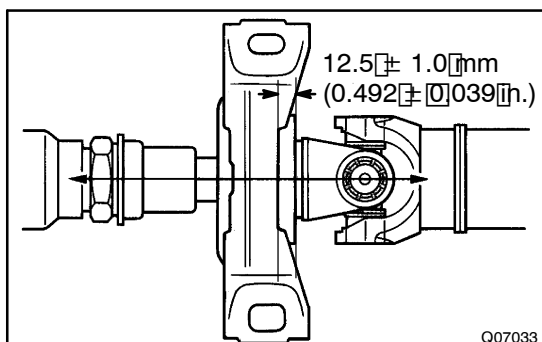

(h) Torque the 2 center support bearing set bolts.

**Torque: 37 N·m (375 kgf·cm, 27 ft·lbf)**

HINT:

Adjust the center support bearing to keep the intervals as shown with the vehicle in the unladen condition.

Under the same condition, check if the center line of the center support bearing is at right angles to the shaft axial direction.

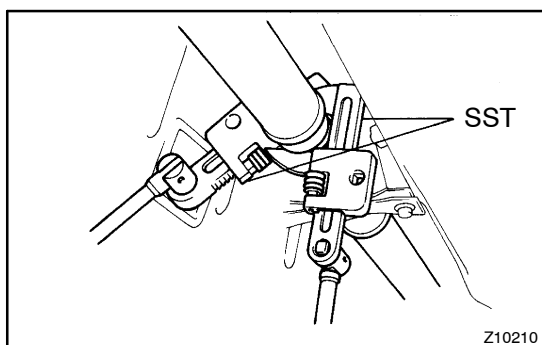

(i) Using SST, tighten the adjusting nut.

SST 09922-10010

**Torque: 50 N·m (515 kgf·cm, 37 ft·lbf)**

HINT:

Use a torque wrench with a fulcrum length of 34.5 cm (13.6 in.).

**2. INSPECT JOINT ANGLE (See page PR-12)**

**NOTICE:**

The joint angle should by all means be checked when the propeller shaft is removed and installed.

### 3. INSTALL HEAT INSULATOR AND UNDER REINFORCEMENT

(a) Install the front floor insulator No. 1 with the 6 bolts.

**Torque: 5.5 N·m (56 kgf·cm, 49 in·lbf)**

(b) Install the front under reinforcement with the 4 bolts.

**Torque: 13 N·m (132 kgf·cm, 10 ft·lbf)**

(c) Install the center floor under reinforcement with the 4 nuts.

**Torque: 13 N·m (132 kgf·cm, 10 ft·lbf)**

### 4. INSTALL EXHAUST PIPE ASSEMBLY

(a) Connect the exhaust pipe assembly to the O-rings.

(b) Install the 2 gaskets and connect the exhaust pipe assembly to the exhaust manifold.

(c) Install the 2 catalytic converter supporting brackets and 4 bolts, to the exhaust manifold.

**Torque: 43 N·m (440 kgf·cm, 32 ft·lbf)**