

IACV Control VSV Circuit

CIRCUIT DESCRIPTION

This circuit opens and closes the IACV (Intake Air Control Valve) in response to the engine load in order to increase the intake efficiency (ACIS: Acoustic Control Induction System).

When the engine speed is 2,300 – 3,500 rpm or less and the throttle valve opening angle is 10° or more, the engine ECU turns the VSV ON and closes the IACV. In the other conditions, the VSV is OFF, so the IACV is open.

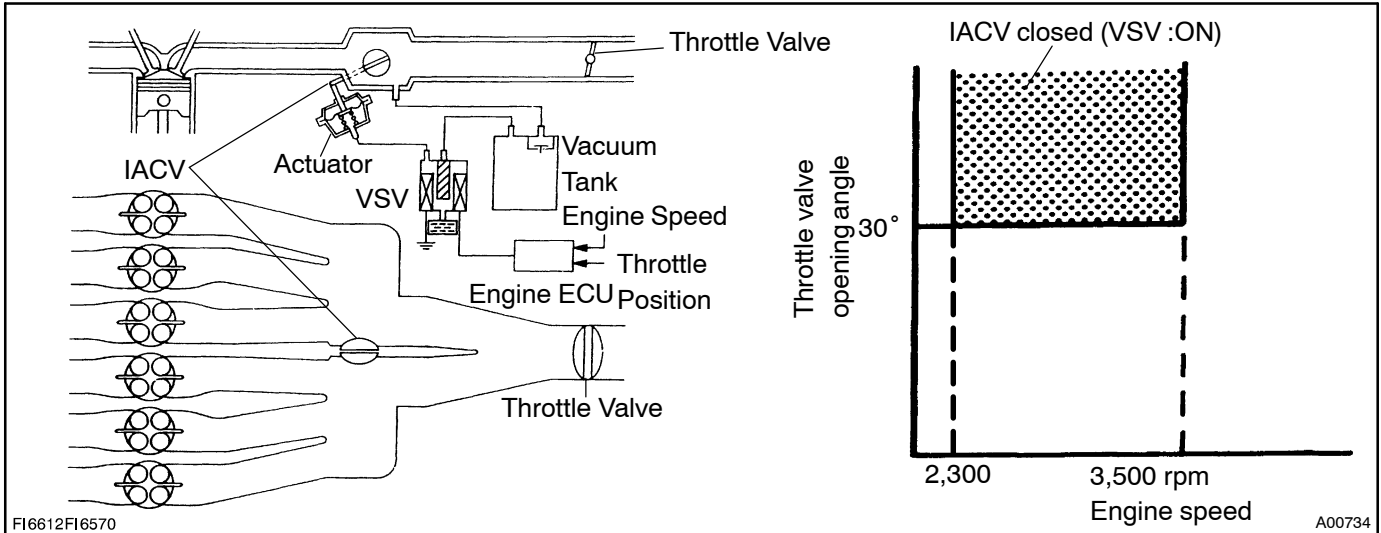

WIRING DIAGRAM

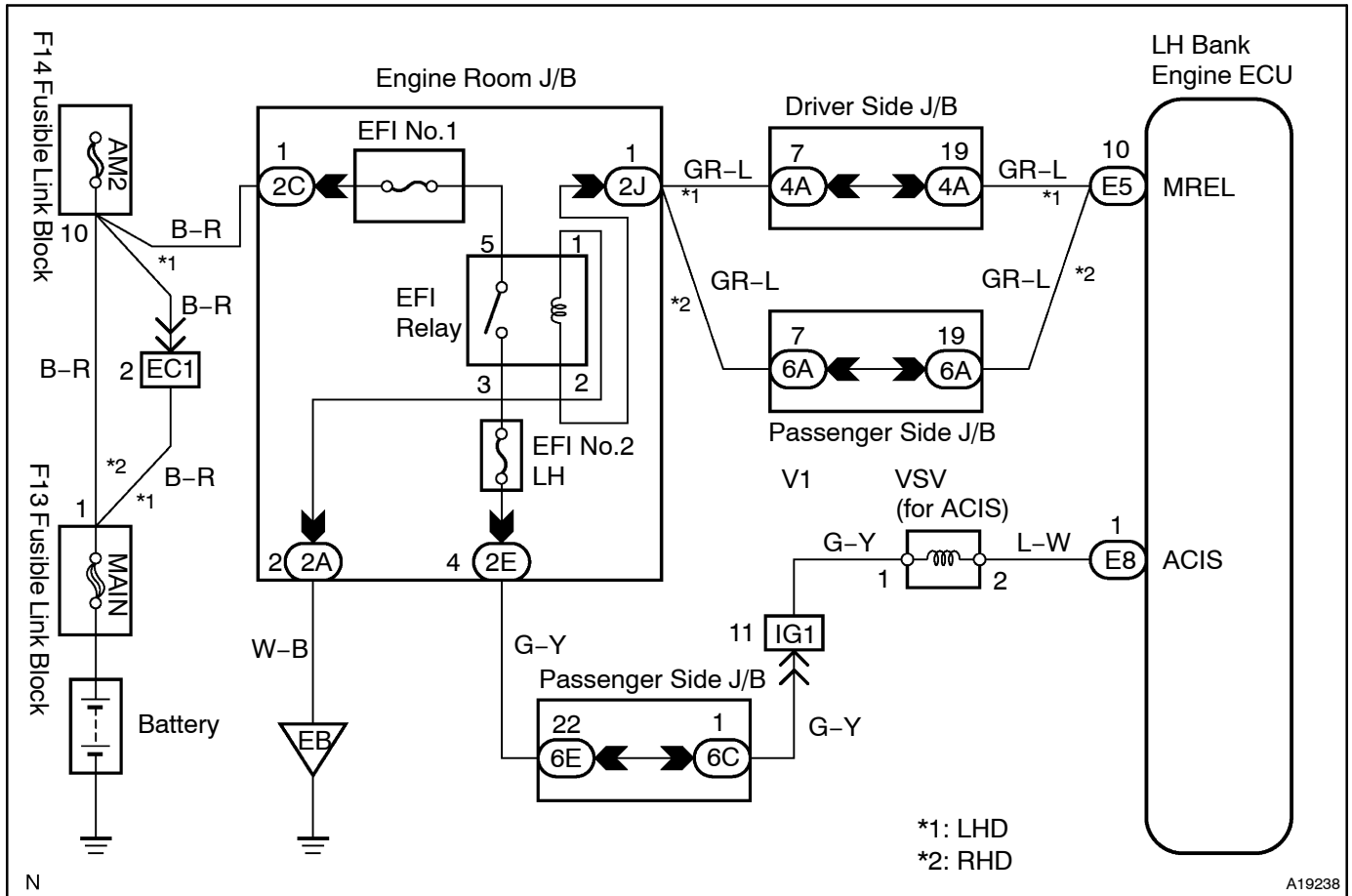

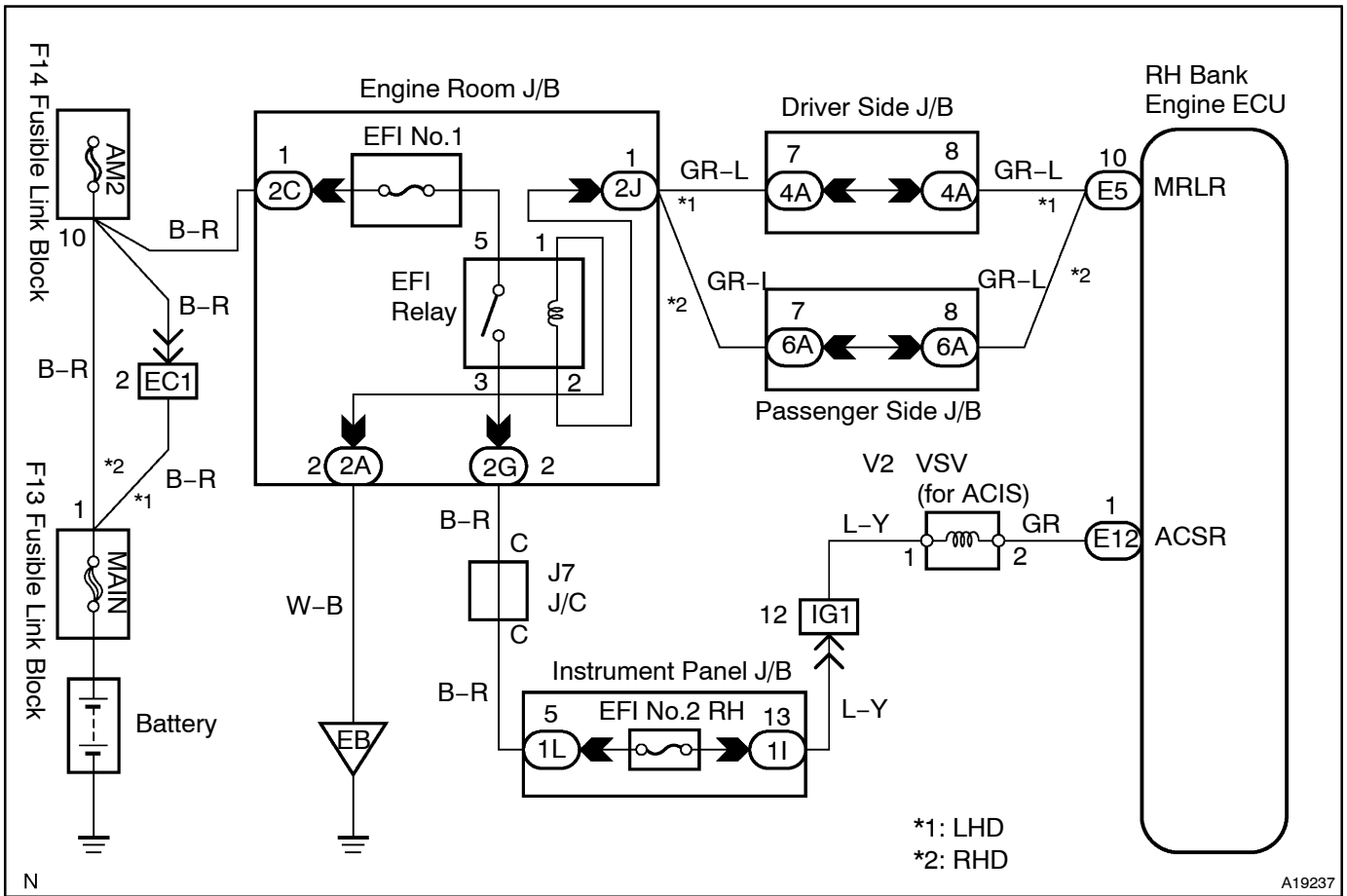

INSPECTION PROCEDURE

HINT:

The inspection procedures are same for both LH and RH bank engine ECU and described in this manual. Even though terminal name and part name on the side of RH bank are described in parenthesis, perform the inspection for only defective ECU.

When using hand-held tester

1 Connect hand-held tester and check operation of VSV for ACIS.

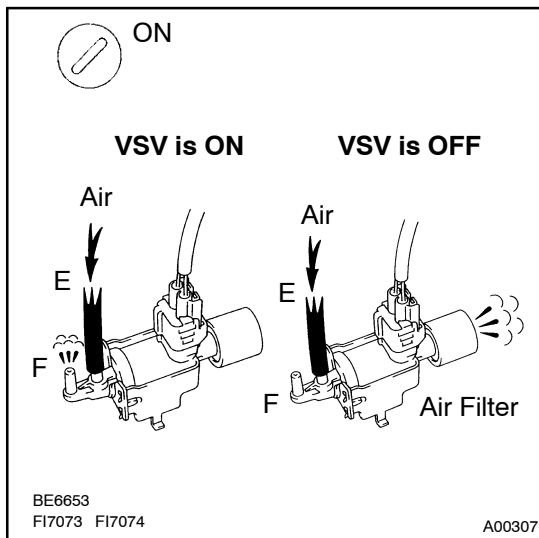

PREPARATION:

- Connect the hand-held tester to the DLC3.
- Turn the ignition switch to ON and hand-held tester main switch to ON.
- Select ACTIVE TEST mode on the hand-held tester.

CHECK:

Check operation of the VSV when VSV is operated by the hand-held tester.

OK:

VSV is ON:

Air from pipe E is flowing out through pipe F.

VSV is OFF:

Air from pipe E is flowing out through the air filter.

OK

Check for vacuum tank (See Pub. No. RM677E, page FI-43).

NG

2 Check VSV for ACIS (See Pub. No. RM677E, page FI-43).

NG

Replace VSV for ACIS.

OK

- 3 Check for open and short in harness and connector between EFI main relay and engine ECU (See page IN-20).

NG

Repair or replace harness or connector.

OK

Check and replace engine ECU
(See page IN-20).

When not using hand-held tester

- 1 Check VSV for ACIS (See page Pub. No. RM677E, page FI-43).

NG

Replace VSV for ACIS.

OK

- 2 Check voltage between terminal ACIS (ACSR) of engine ECU connector and body ground.

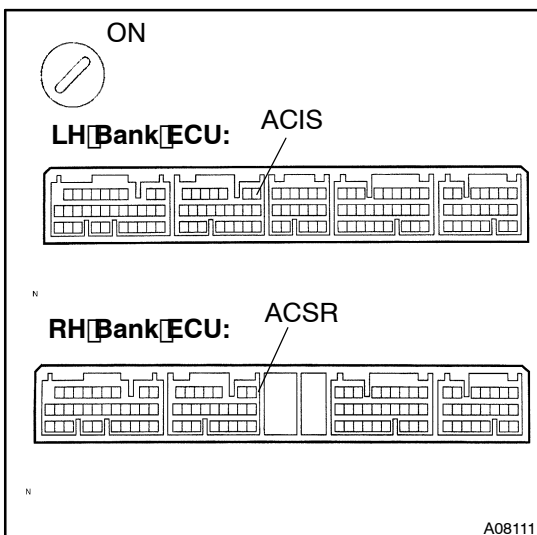

PREPARATION:

- (a) Remove the engine ECU with connectors still connected.
(b) Turn the ignition switch to ON.

CHECK:

Measure voltage between terminal ACIS (ACSR) of the engine ECU connector and body ground.

OK:

Voltage: 9 - 14 V

NG

Check for open and short in harness and connector between EFI main relay and engine ECU (See page IN-20).

OK

3 Check for vacuum tank (See Pub. No. RM677E, page FI-43).

NG

Repair or replace.

OK

Check and replace engine ECU
(See [page N-20](#)).