

FRONT DOOR OUTER PANEL (ASSY)**REMOVAL**

1. After grinding off the hemming location, remove the outer panel.

INSTALLATION

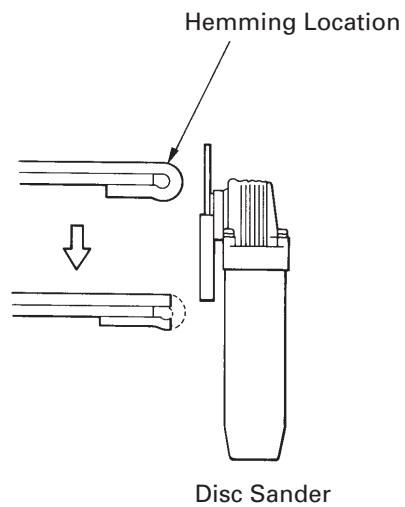
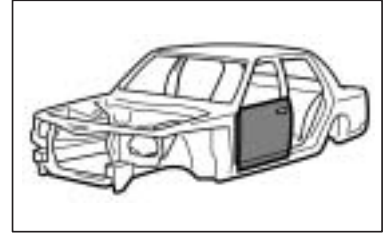
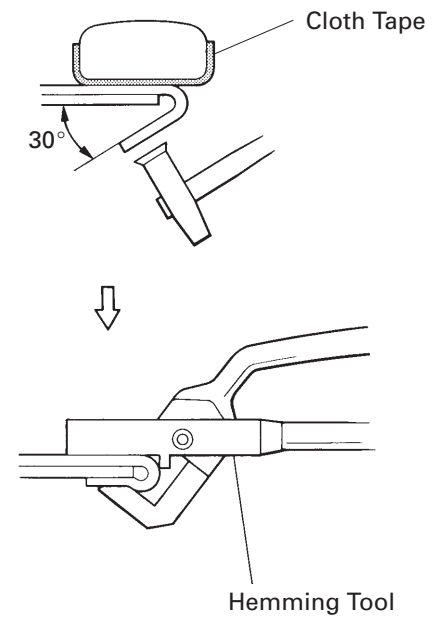
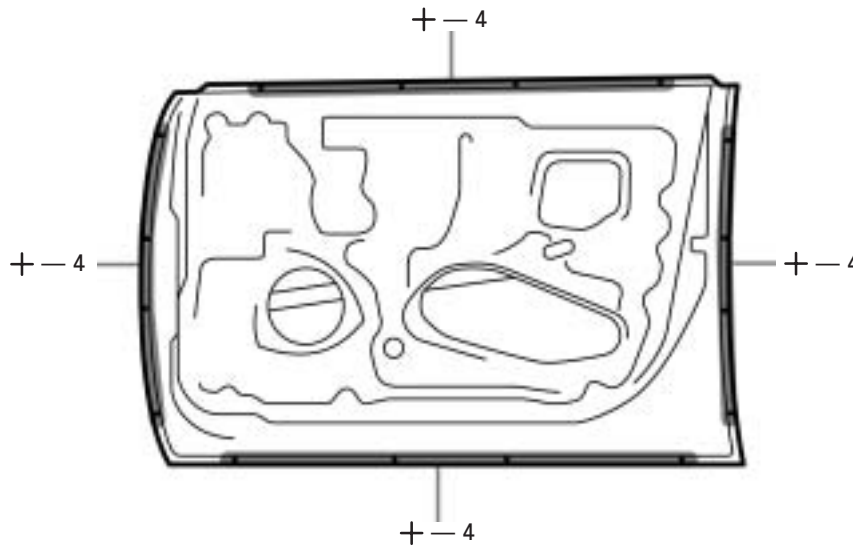
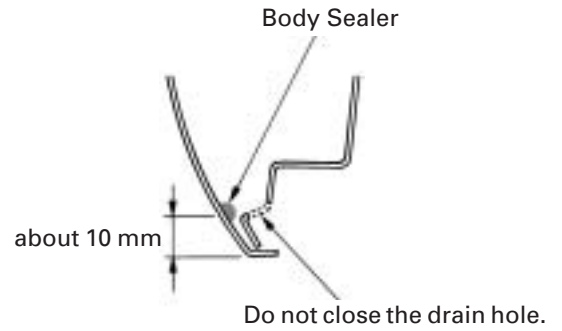
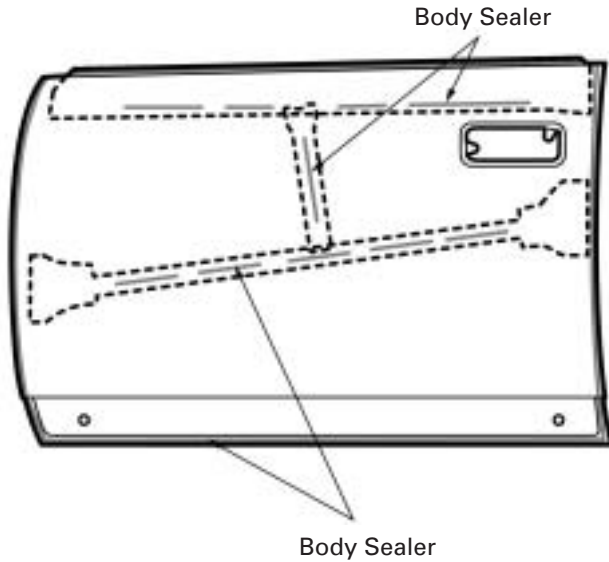

mm	in.
10	0.39

1. Before temporarily installing the new parts, apply body sealer to the reinforcement, side impact protection beam and back side of the new parts.
HINT:
1) Apply sealer evenly about 10 mm (0.39 in) from the flange and 3 mm (0.12 in.) in diameter to the outer panel and apply just enough sealer for the reinforcement and side impact protection beam to make contact.
2) For other sealing points, refer to section AR.
2. Bend the flange hem about 30° with a hammer and dolly, then fasten tightly with a hemming tool.
HINT:
1) Perform hemming in three steps, being careful not to warp the panel.
2) If a hemming tool cannot be used, hem with a hammer and dolly.