

COWL TOP SIDE PANEL (ASSY)

REMOVAL (With the cowl top to apron brace removed.)

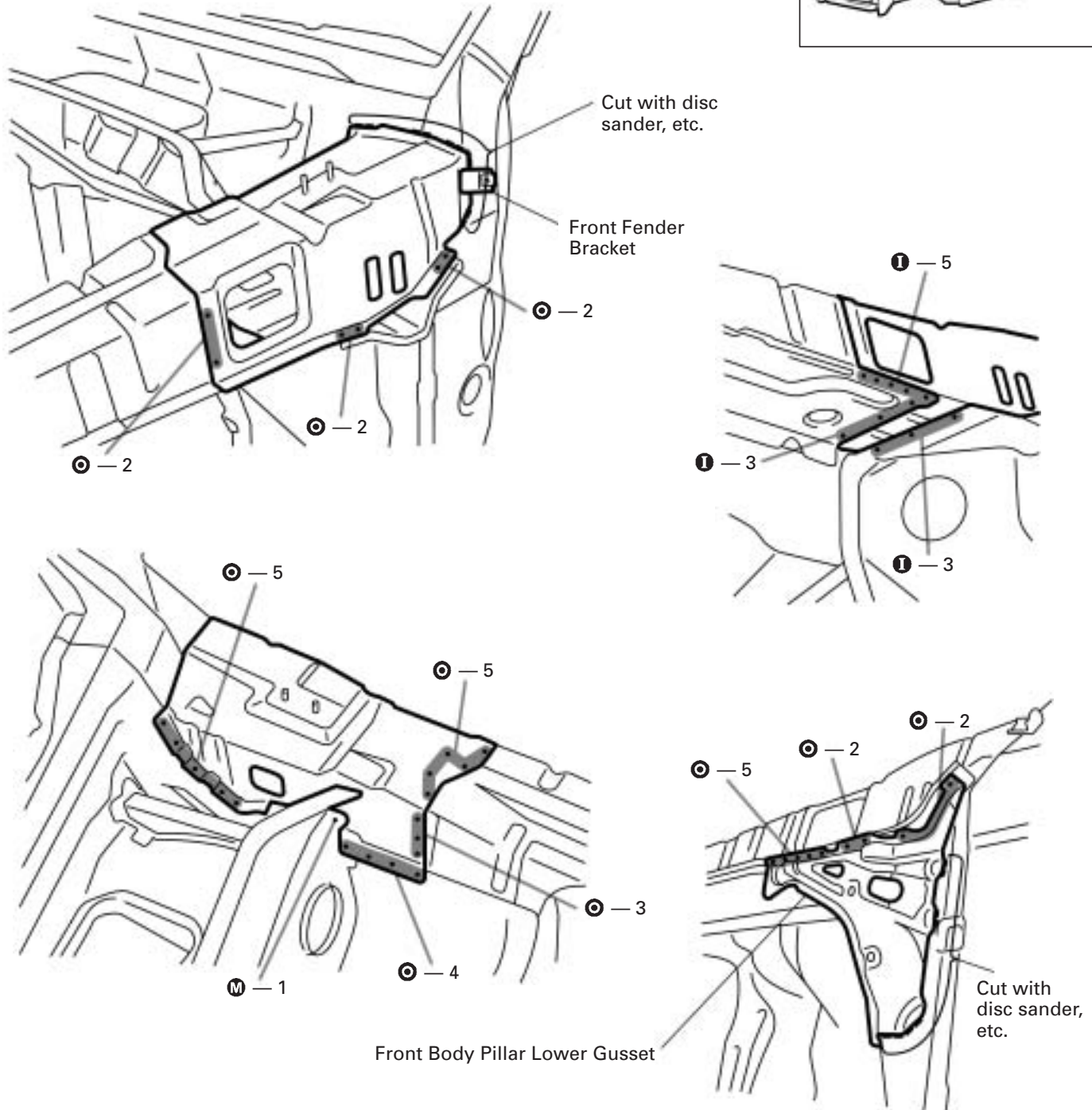
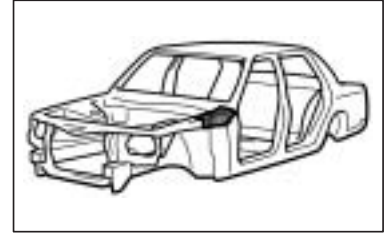

1. Replace the front fender bracket at the same time.
2. After removing the front body pillar lower gusset, remove the cowl top side panel.

INSTALLATION

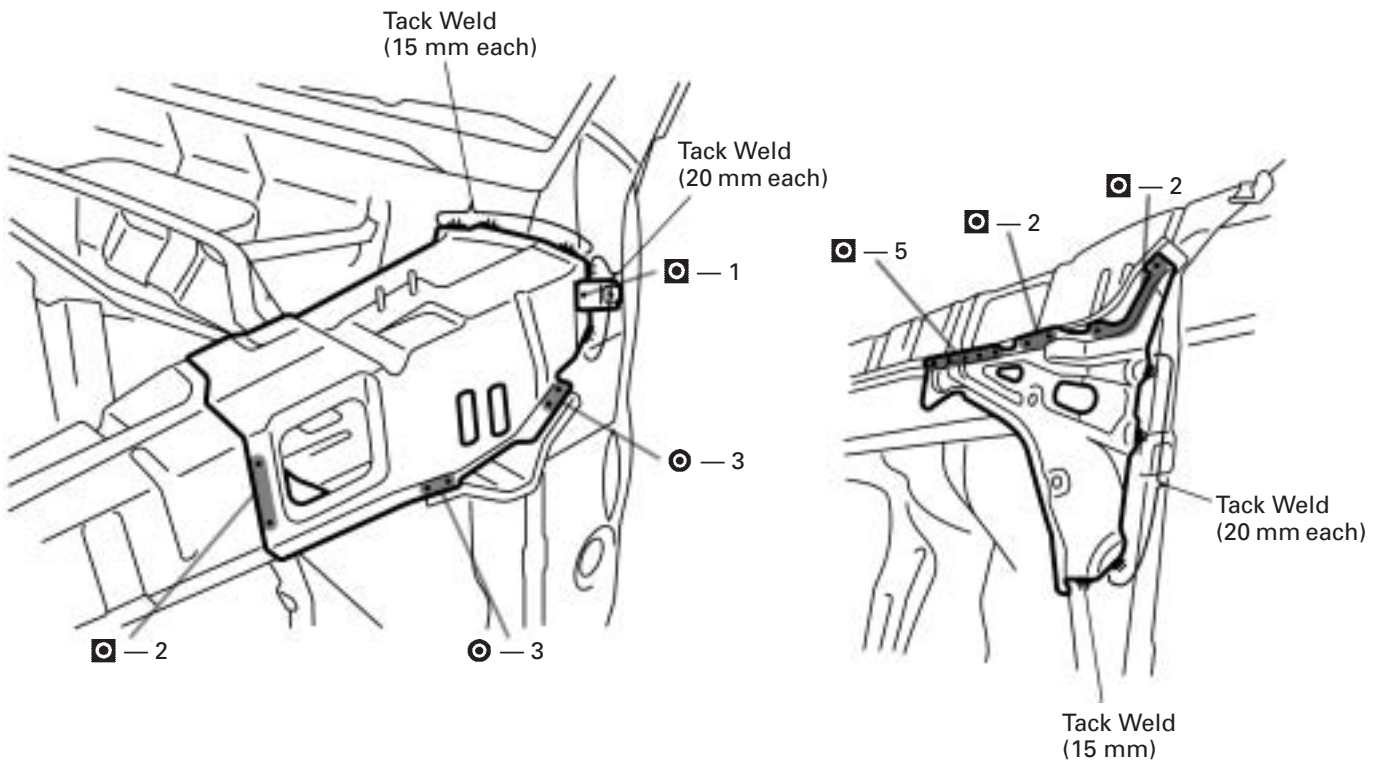
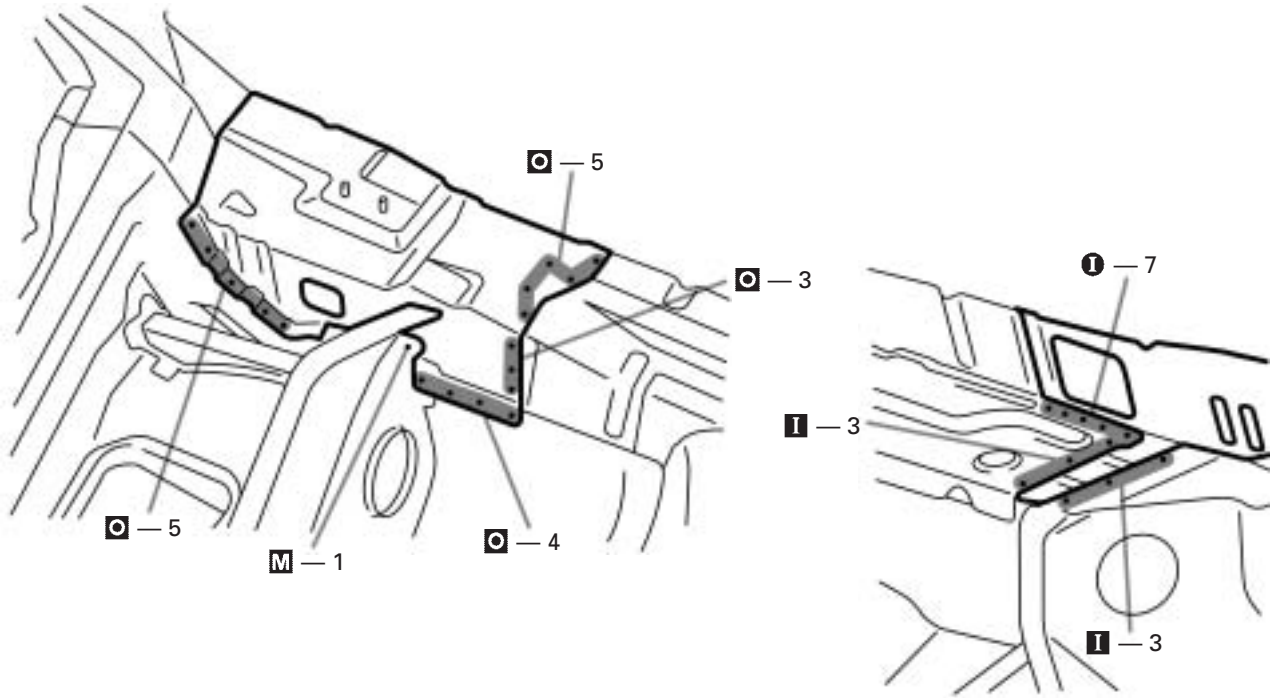

1. Temporarily install the new parts and measure each part accordance with the body dimension diagram.

mm	in.
15	0.59
20	0.79