

TRC OFF Indicator, TRC Cut Switch Circuit

CIRCUIT DESCRIPTION

This is the TRC control main switch. When the TRC cut switch is pushed on, TRC control goes off and the TRC OFF indicator lights up. This indicator blinks for warnings when the trouble occurs and for displaying DTC.

WIRING DIAGRAM

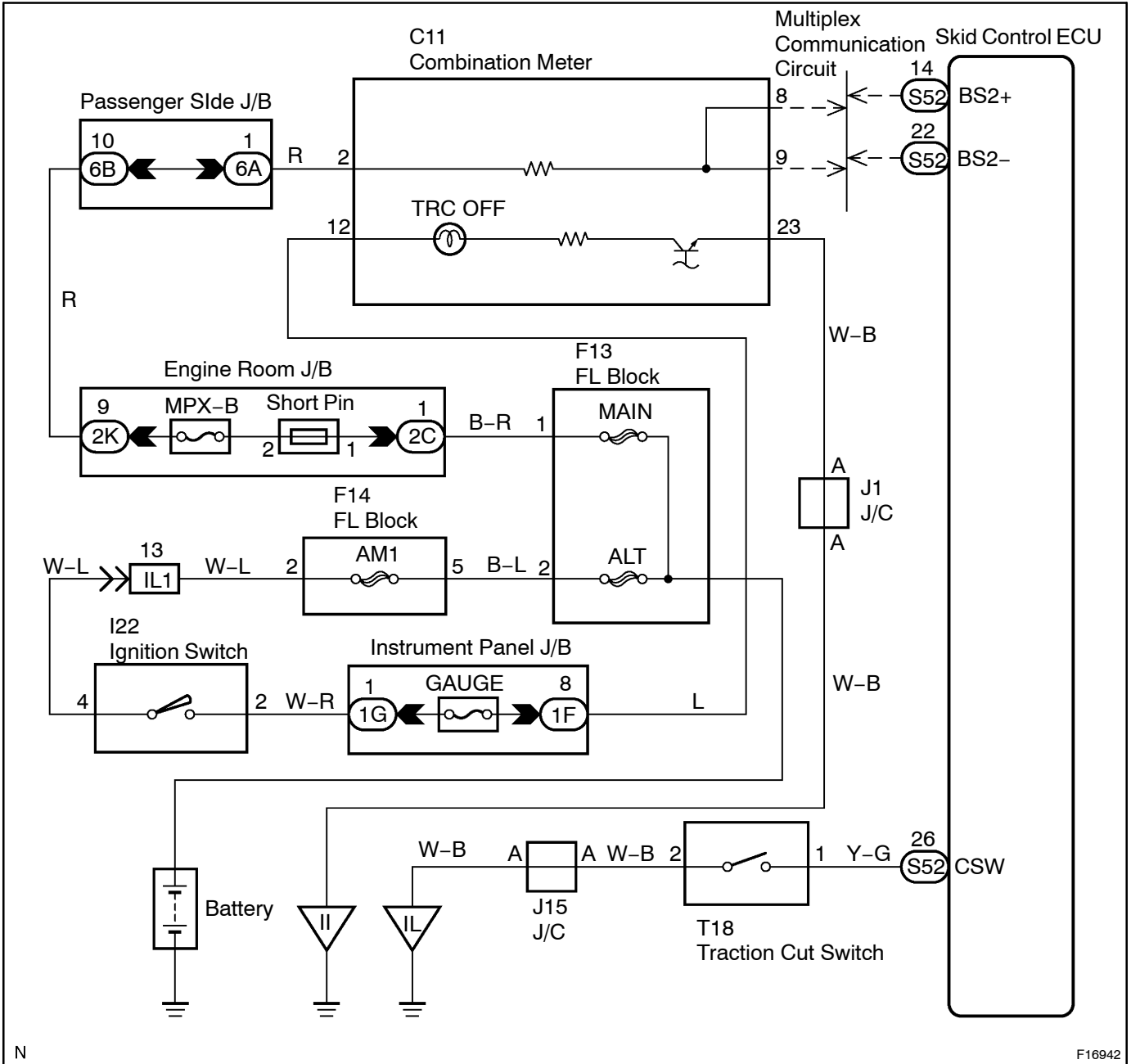

N

F16942

INSPECTION PROCEDURE

HINT:

Start the inspection from step 1 in case of using the hand-held tester and start from step 2 in case of not using the hand-held tester.

1	Check operation of the TRC OFF indicator light.
----------	--

PREPARATION:

- (a) Connect the hand-held tester to the DLC3.
- (b) Turn the ignition switch to ON and push the hand-held tester main switch to ON.
- (c) Select the ACTIVE TEST mode on the hand-held tester.

CHECK:

Check that "ON" and "OFF" of the TRC OFF indicator light can be shown on the combination meter by the hand-held tester.

OK

Go to step 3.

NG

2	Check TRC OFF indicator light.
----------	---------------------------------------

See combination meter troubleshooting.

NG

Repair or replace combination meter assembly.

OK

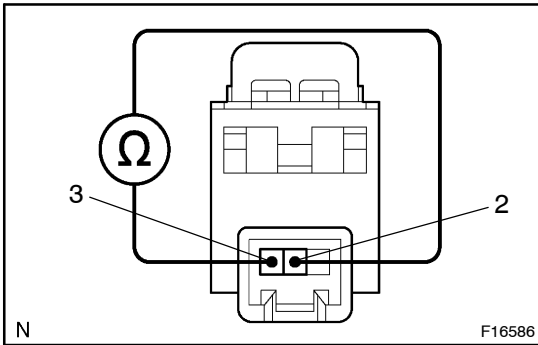
3 Check TRC OFF switch.**PREPARATION:**

Remove the TRC OFF switch and disconnect the connector from the TRC OFF switch.

CHECK:

Measure resistance between terminals 2 and 3 of TRC OFF switch when TRC OFF switch is on and off.

OK:

TRC OFF switch	Resistance
Pushed in	Continuity
Released	1 MΩ or higher

NG**Replace TRC OFF switch.****OK****4 Check for open and short circuit in harness and connector between terminal CSW of skid control ECU and TRC OFF switch and body ground (See page IN-31).****NG****Repair or replace harness or connector.****OK****5 Check for open and short circuit in multiplex communication system between skid control ECU and combination meter (See page IN-31).****NG****Repair or replace multiples communication system.****OK****Check and replace skid control ECU.**