

INSTALLATION

1. INSTALL QUARTER OUTSIDE MOULDING

- (a) Using a heat light, heat the body mounting surface to 40 – 60 °C (104 – 140 °F).
- (b) Remove the adhesive tape from the body.
- (c) Wipe off stain with cleaner.

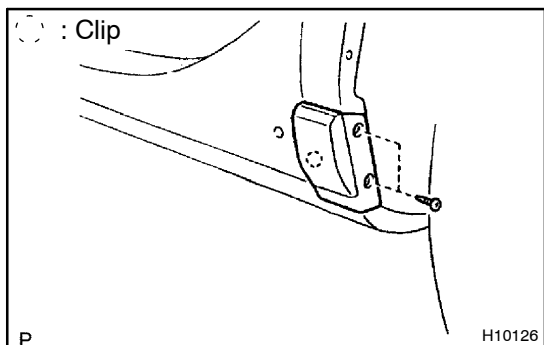

- (d) Using a heat light, heat the body and a new moulding.
Body: 40 – 60 °C (104 – 140 °F)
Moulding: 20 – 30 °C (68 – 86 °F)

NOTICE:

Do not heat the moulding excessively.

- (e) Lift the moulding release sheet face of moulding.

NOTICE:

When the moulding release sheet is removed, make sure that no dirt or dust can get onto the uncoated area.

- (f) Install the quarter outside moulding with 2 screws.

2. INSTALL REAR DOOR OUTSIDE MOULDING LOWER

- (a) Using a heat light, heat the body mounting surface to 40 – 60 °C (104 – 140 °F).
- (b) Remove the adhesive tape from the body.
- (c) Wipe off stain with cleaner.

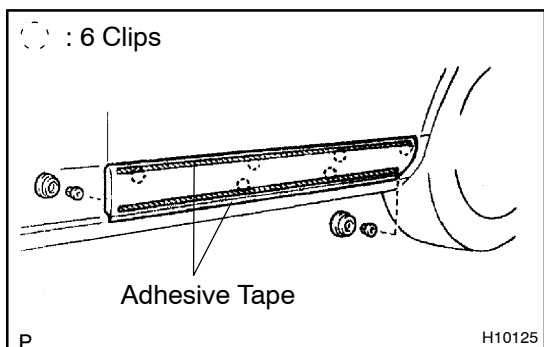

- (d) Using a heat light, heat the body and a new moulding.
Body: 40 – 60 °C (104 – 140 °F)
Moulding: 20 – 30 °C (68 – 86 °F)

NOTICE:

Do not heat the moulding excessively.

- (e) Lift the moulding release sheet face of moulding.

NOTICE:

When the moulding release sheet is removed, make sure that no dirt or dust can get onto the uncoated area.

- (f) Install the rear door outside moulding lower with 2 nuts and 2 hole plugs.

3. INSTALL FRONT DOOR OUTSIDE MOULDING LOWER

- (a) Using a heat light, heat the body mounting surface to 40 – 60 °C (104 – 140 °F).
- (b) Remove the adhesive tape from the body.
- (c) Wipe off stain with cleaner.

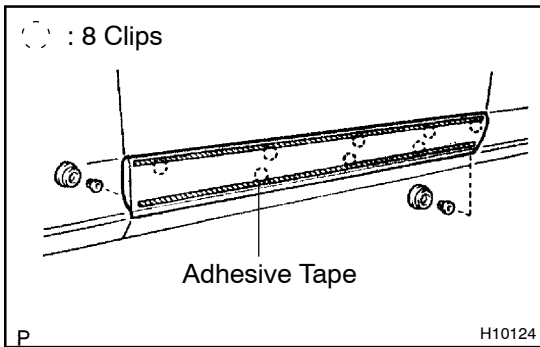

- (d) Using a heat light, heat the body and a new moulding.
Body: 40 – 60 °C (104 – 140 °F)
Moulding: 20 – 30 °C (68 – 86 °F)

NOTICE:

Do not heat the moulding excessively.

- (e) Lift the moulding release sheet face of moulding.

NOTICE:

When the moulding release sheet is removed, make sure that no dirt or dust can get onto the uncoated area.

- (f) Install the front door outside moulding lower with 2 nuts and 2 hole plugs.

4. INSTALL FRONT SIDE PANEL MOULDING

- (a) Using a heat light, heat the body mounting surface to 40 – 60 °C (104 – 140 °F).
 (b) Remove the adhesive tape from the body.
 (c) Wipe off stain with cleaner.

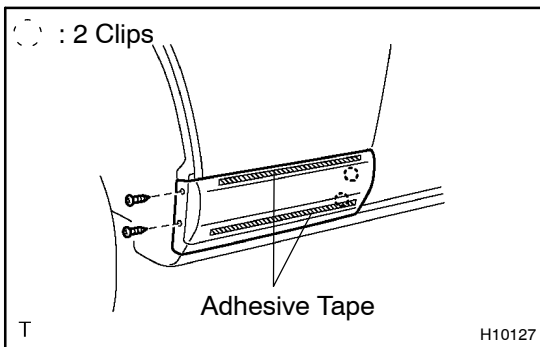

- (d) Using a heat light, heat the body and a new moulding.
Body: 40 – 60 °C (104 – 140 °F)
Moulding: 20 – 30 °C (68 – 86 °F)

NOTICE:

Do not heat the moulding excessively.

- (e) Lift the moulding release sheet face of moulding.

NOTICE:

When the moulding release sheet is removed, make sure that no dirt or dust can get onto the uncoated area.

- (f) Install the front side panel moulding with 2 screws.