

# COMPONENTS

RHD:

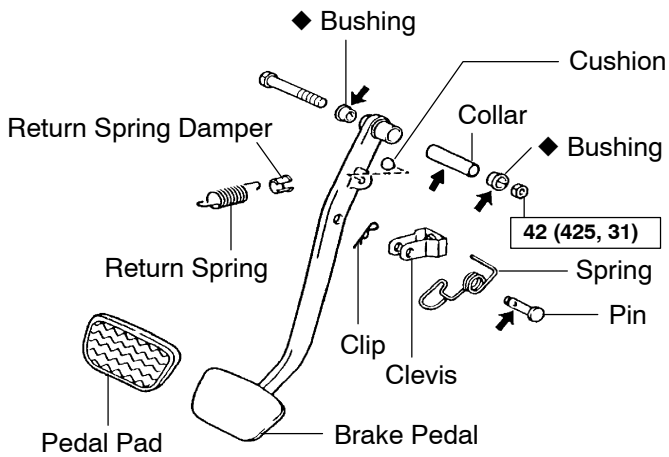

LHD:

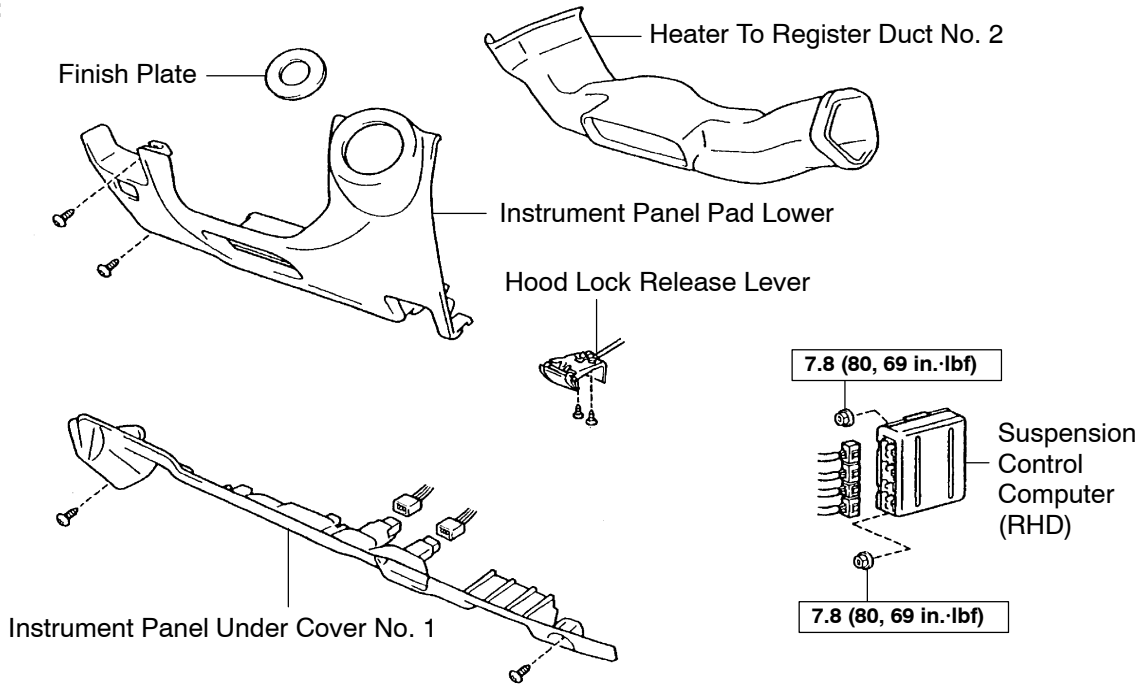
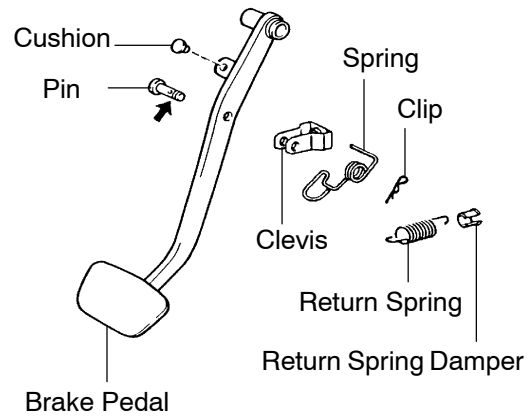

N·m (kgf·cm, ft·lbf) : Specified torque

◆ Non-reusable part

← Lithium soap base glycol grease