

CYLINDER HEAD COMPONENTS

EM10P-01

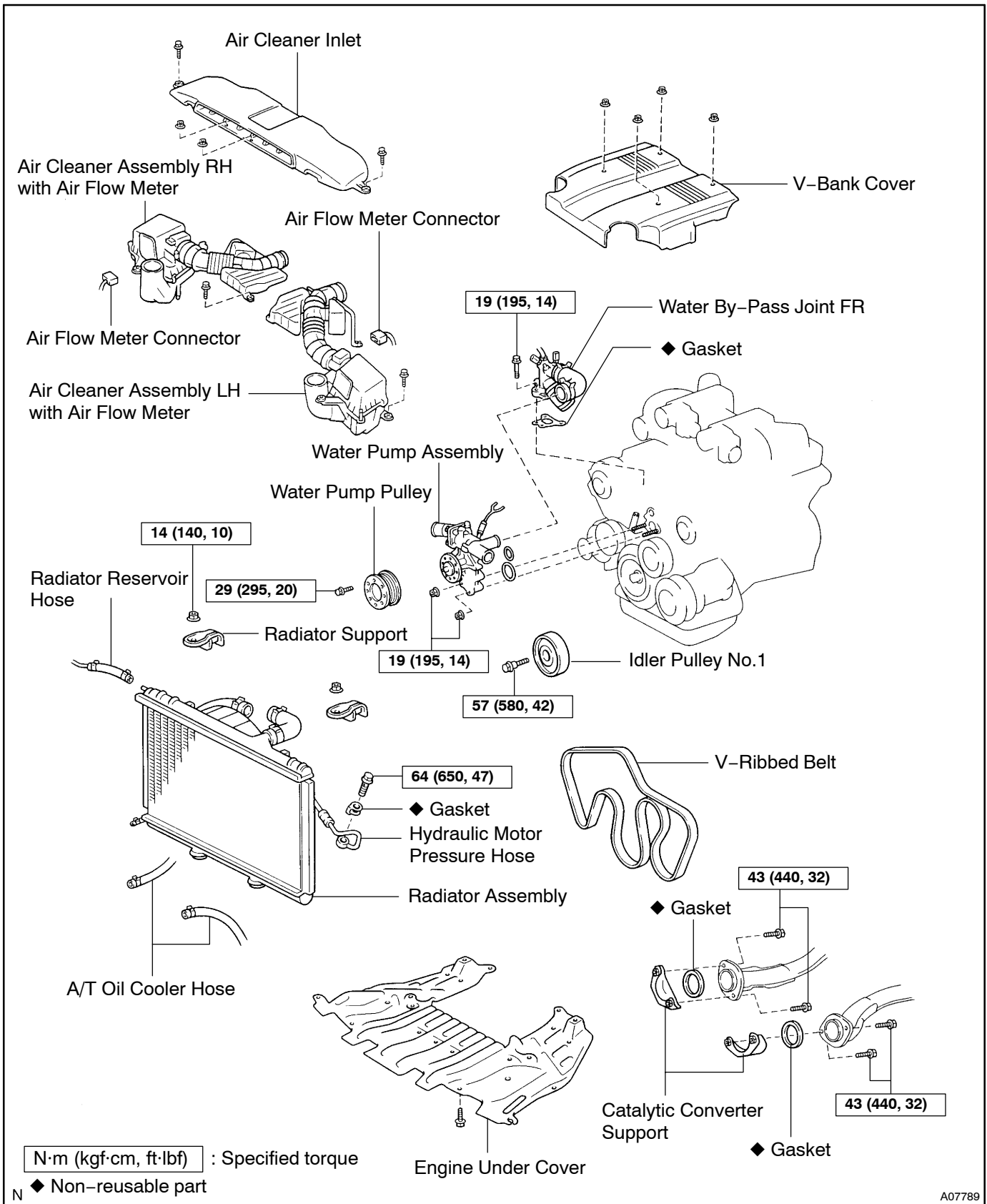

A07789

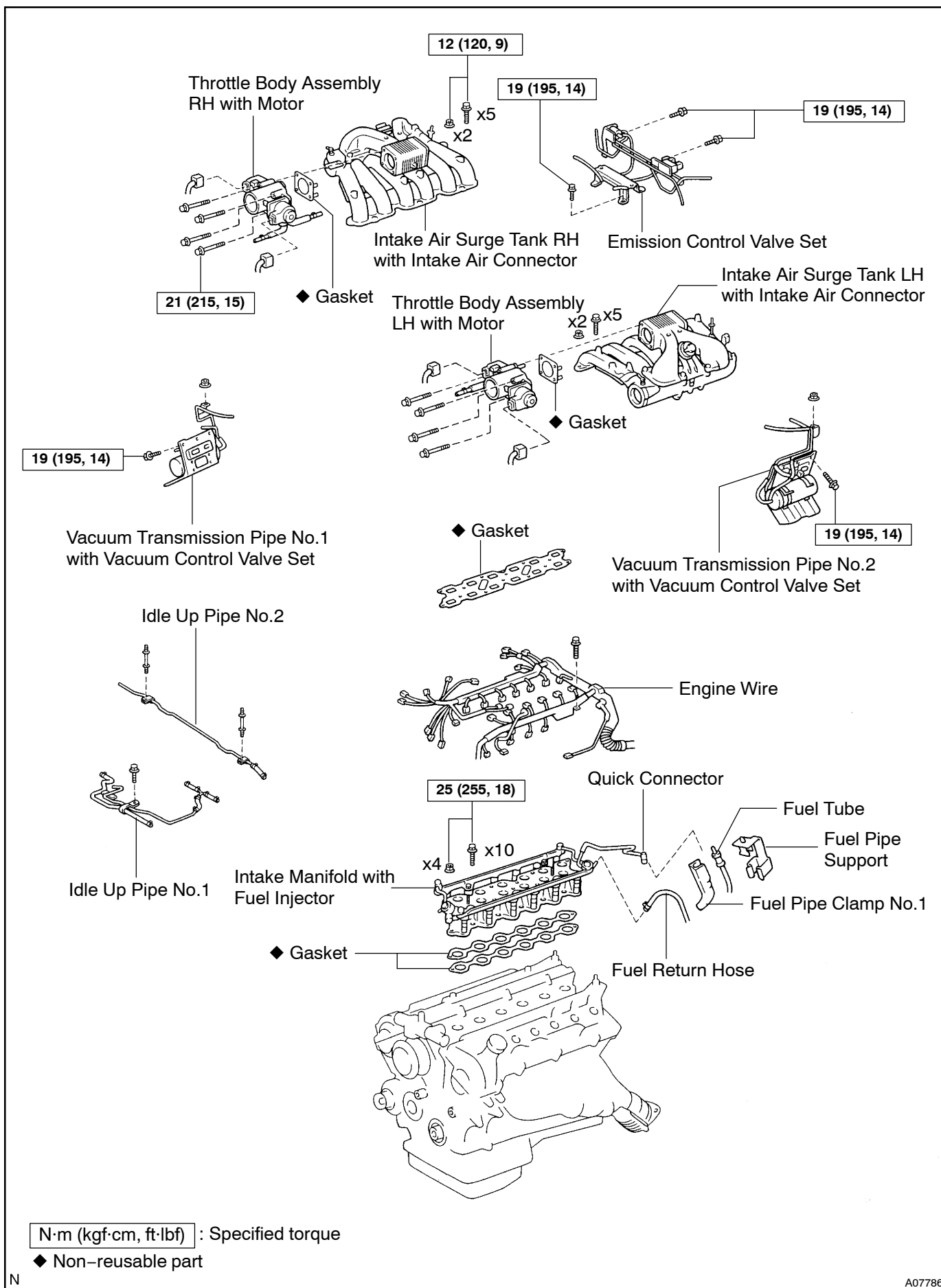

N

A07786

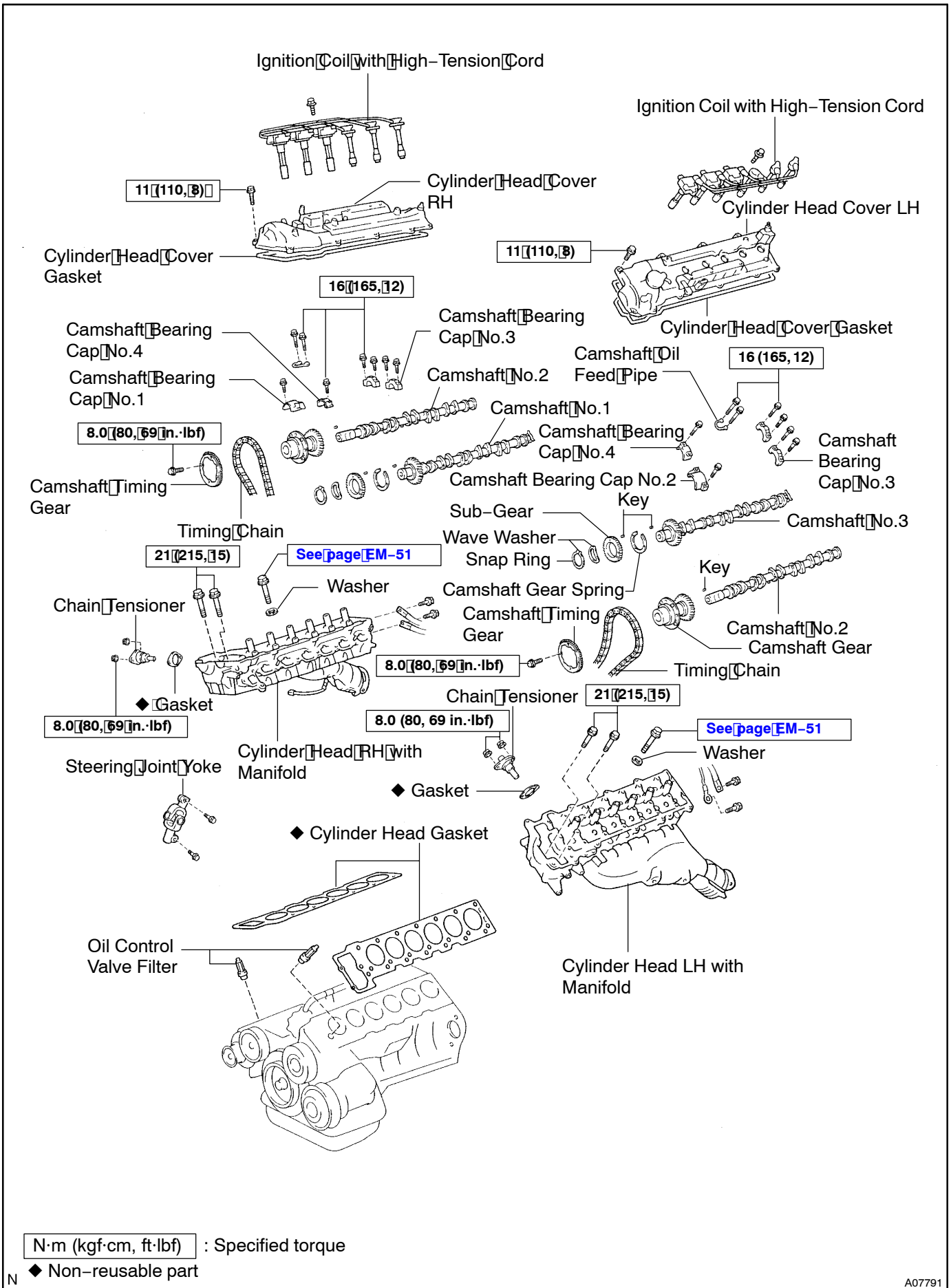

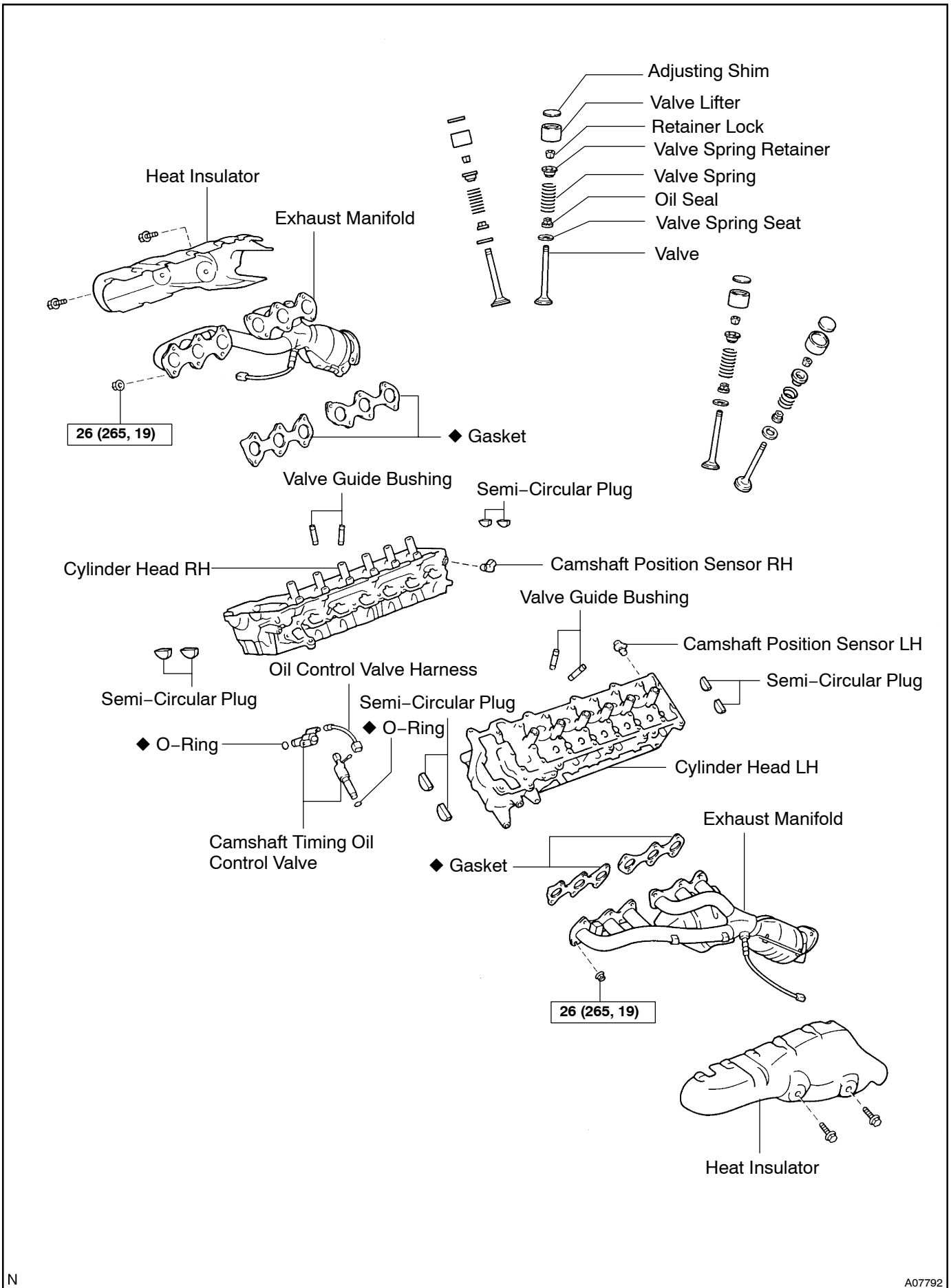

N

A07792