

REPLACEMENT

1. REMOVE OIL SEAL

- (a) Using snap ring pliers, remove the snap ring and plate washer.

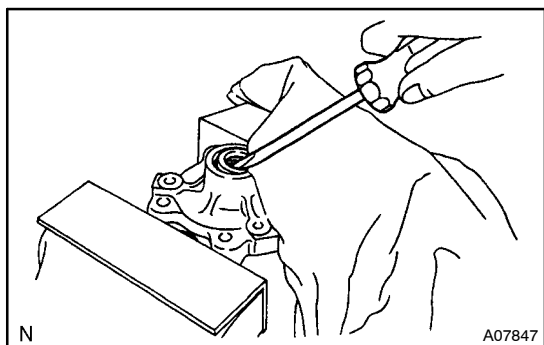

- (b) Using a screwdriver, pry out the oil seal.

NOTICE:

Be careful not to damage the housing.

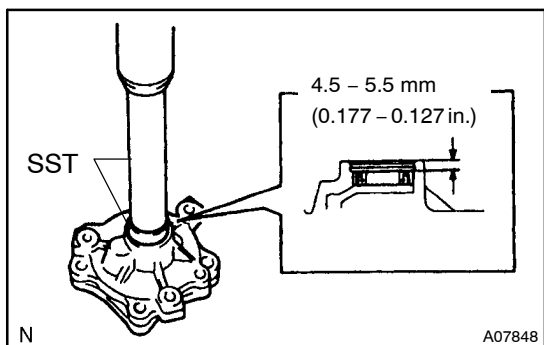

2. INSTALL OIL SEAL

- (a) Using SST and a press, press in a new oil seal to a depth of 4.5 – 5.5 mm (0.177 – 0.217 in.) from the housing edge.
 SST 09950-60010 (09951-00220)
 09950-70010 (09951-07100)
- (b) Using a snap ring pliers, install the plate washer and snap ring.
- (c) Apply fluid to the oil seal lip.