

Rear A/C amplifier circuit

WIRING DIAGRAM

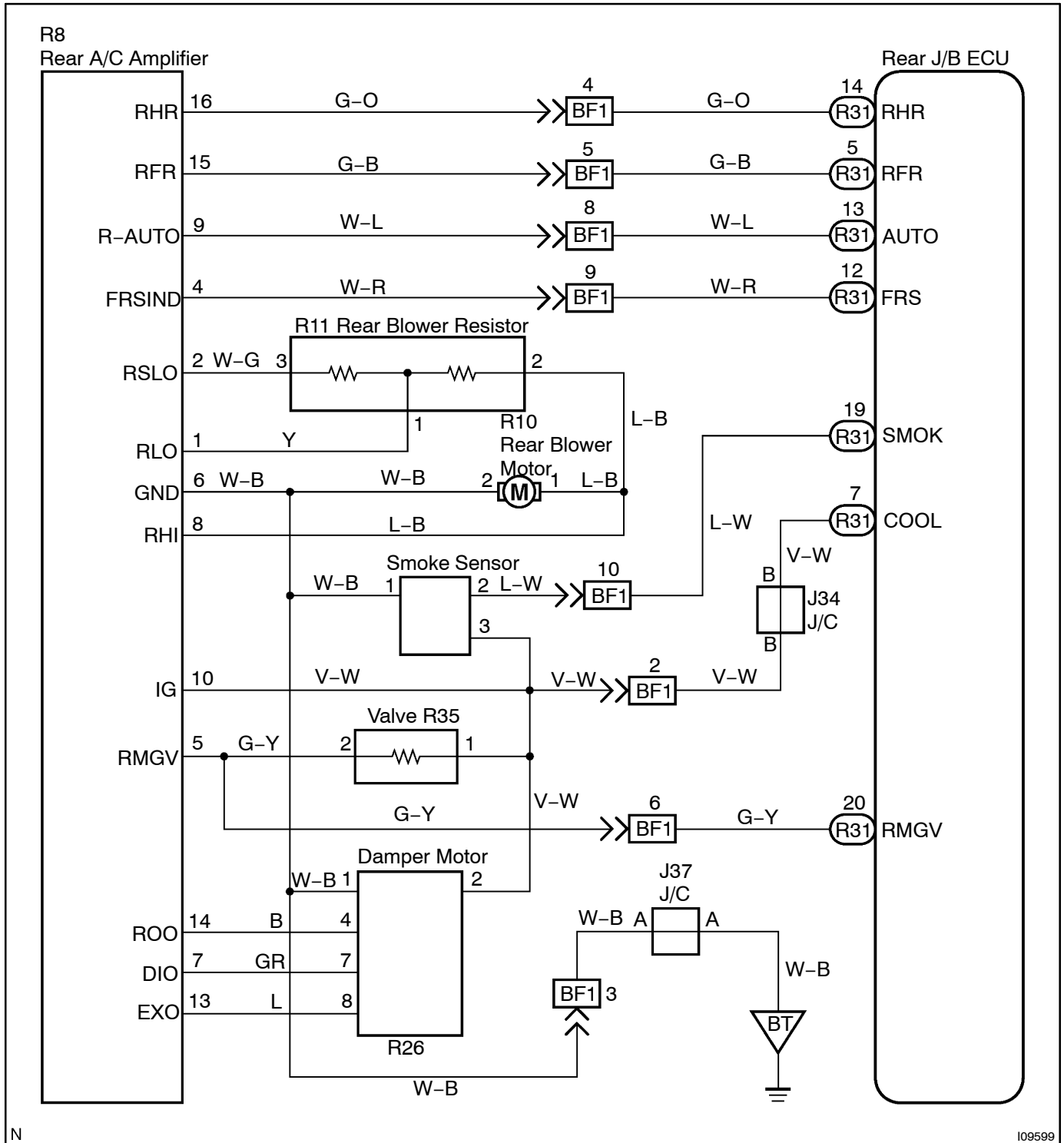

N

109599

INSPECTION PROCEDURE

1 Check wire harness and connector between rear A/C amplifier and rear J/B ECU (See page IN-30).

NG

Repair or replace wireharness or connector.

OK

Proceed to next circuit inspection shown on problem symptoms table (See page DI-665).