

# Back Up Power Source Circuit

## CIRCUIT DESCRIPTION

Battery positive voltage is supplied to terminal BATT of the engine ECU even when the ignition switch is OFF for use by the diagnostic trouble code memory, air-fuel ratio adaptive control value memory, etc.

## WIRING DIAGRAM

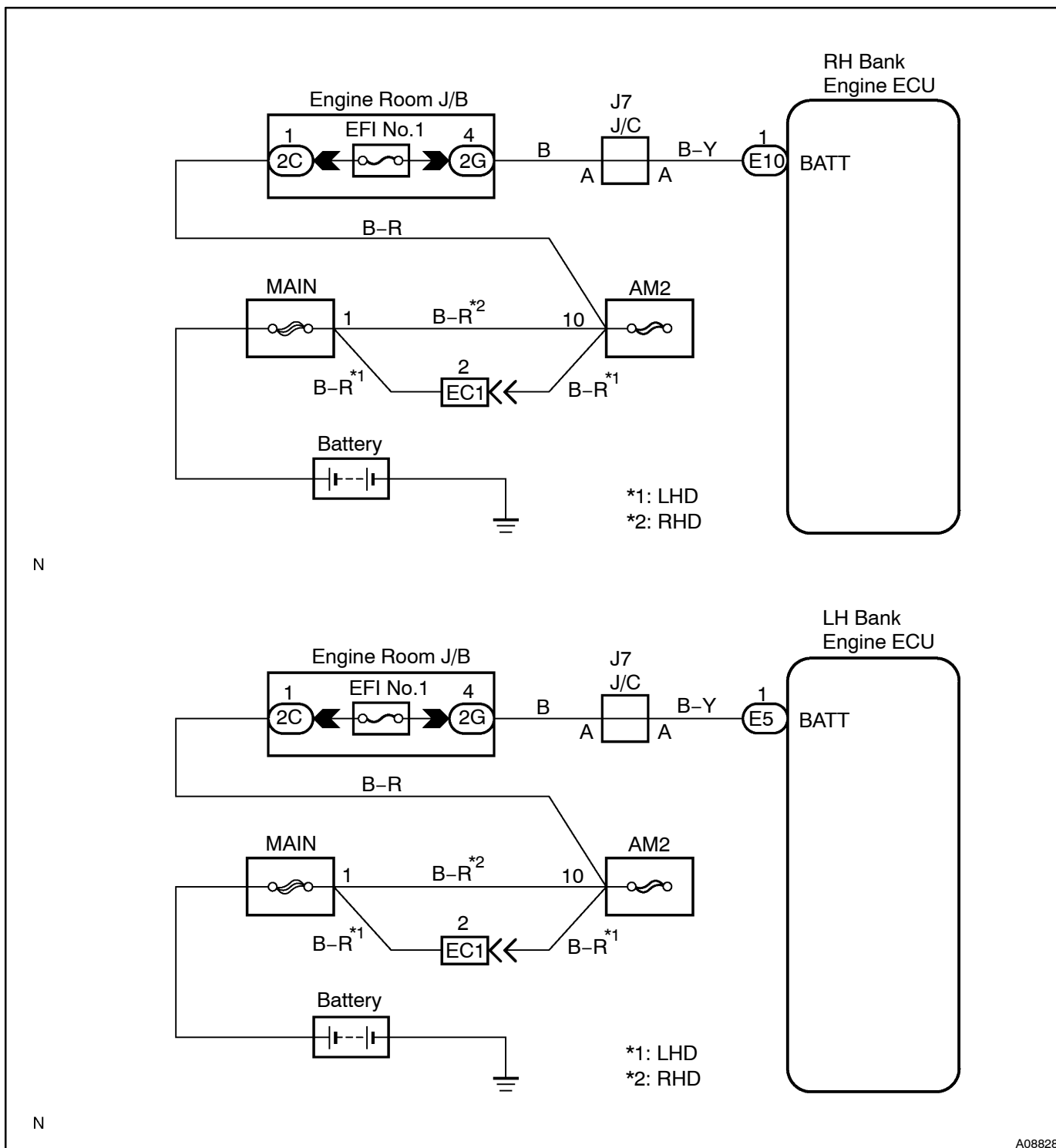

## INSPECTION PROCEDURE

### HINT:

The inspection procedures are same for both LH and RH bank engine ECU and described in this manual. Even though terminal name and part name on the side of RH bank are described in parenthesis, perform the inspection for only defective ECU.

- 1 Check voltage between terminal BATT of engine ECU connector and body ground.**

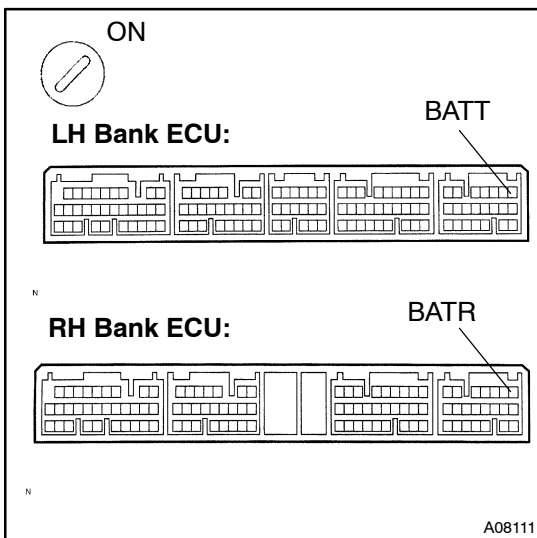

### PREPARATION:

Remove the engine ECU with connectors still connected.

### CHECK:

Measure voltage between terminal BATT (BATR) of engine ECU connector and body ground.

### OK:

**Voltage: 9 - 14 V**

OK

**Check and replace engine ECU (See page IN-20).**

NG

- 2 Check EFI No.1 fuse of engine room J/B.**

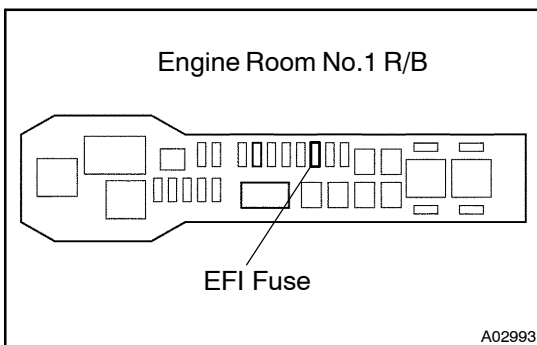

### PREPARATION:

Remove the EFI No.1 fuse from the engine room J/B.

### CHECK:

Check continuity of EFI No.1 fuse.

### OK:

**Continuity**

NG

**Check for short in all harness and components connected to EFI No.1 fuse.**

OK

**Check and repair harness or connector between battery, EFI No.1 fuse and engine ECU.**