

## IGNITION SYSTEM

### 1. General

A DIS (Direct Ignition System) has been adopted in the 1GZ-FE engine. The DIS improves the ignition timing accuracy, reduces high-voltage loss, and enhances the overall reliability of the ignition system by eliminating the distributor.

The DIS in 1GZ-FE engine is a 2-cylinder simultaneous ignition system which has one ignition coil to ignite 2 cylinders simultaneously.

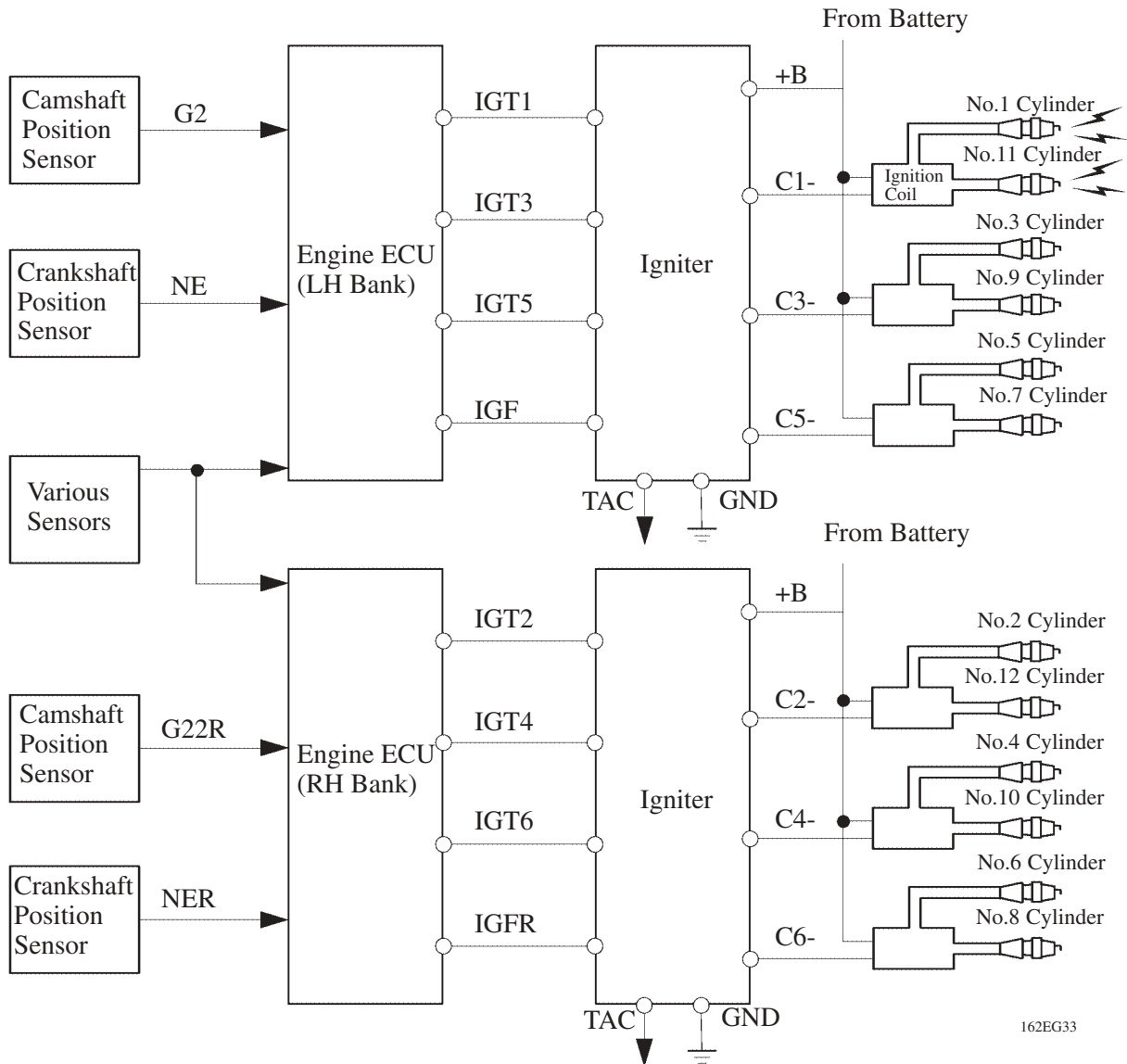

## 2. Spark Plug

Iridium-tipped spark plugs have been adopted. Their center electrode is made of iridium, which excels in wear resistance. As a result, the center electrode is made with a smaller diameter and improved the ignition performance.

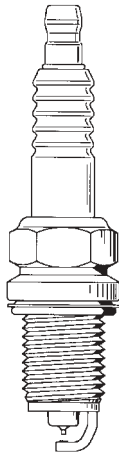

### ► Recommended Spark Plugs ◀

DENSO	● SK16R11
Plug Gap	1.0 – 1.1 mm (0.0394 – 0.043 in.)

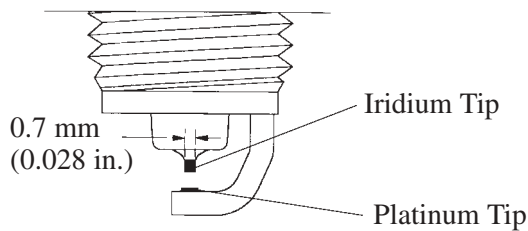

151EG39

## ■ SERPENTINE BELT DRIVE SYSTEM

- The serpentine belt drive system drives accessory components with a single V-ribbed belt. It reduces the overall engine length, weight and number of engine parts.
- An automatic tensioner eliminates the need for tension adjustment.

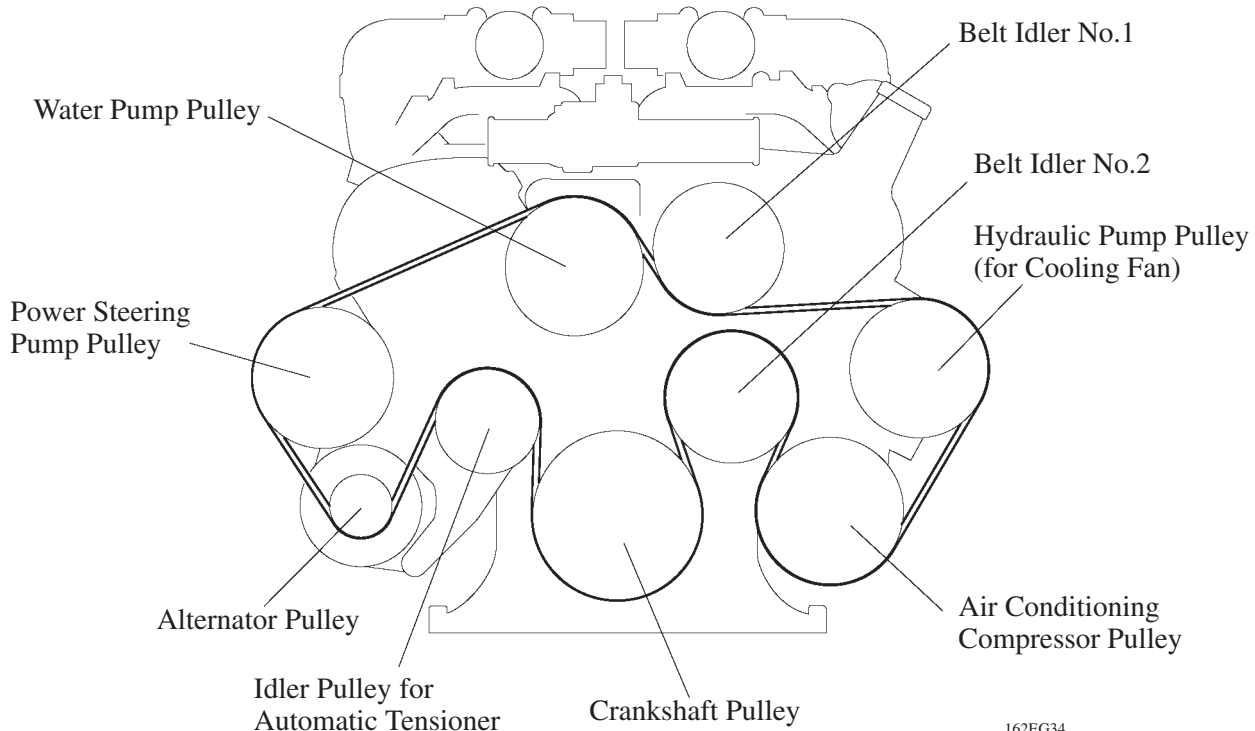

162EG34