

INSPECTION

NOTICE:

- Always use new gaskets when replacing the fuel tank or components parts.
- Apply the proper torque to all parts to be tightened.

INSPECT FUEL LINES AND CONNECTIONS

- Check the fuel lines for cracks or leakage, and all connections for deformation.
- Check the fuel tank vapor vent system hoses and connections for looseness, sharp bends or damage.
- Check the fuel tank for deformation, cracks, fuel leakage or tank band looseness.
- Check the inlet pipe for damage or fuel leakage.

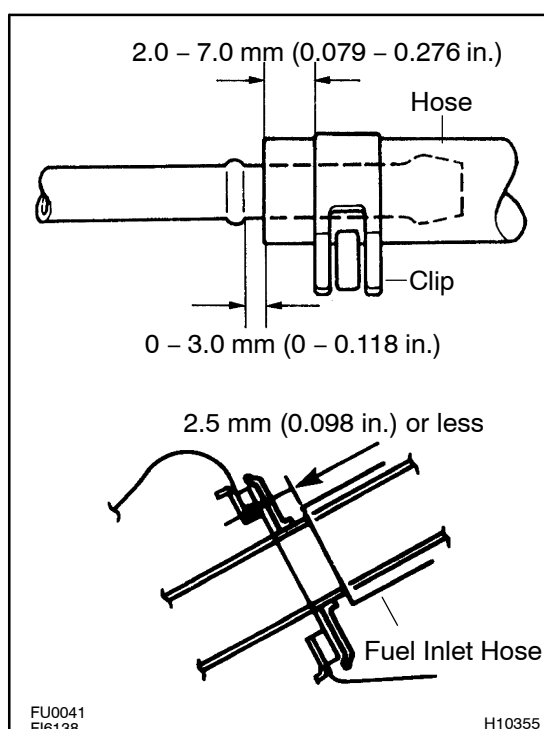
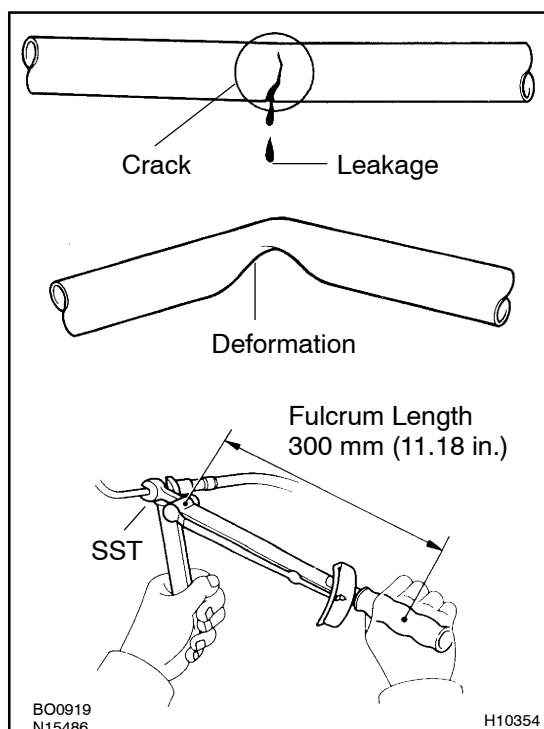

- Hose and tube connections are shown in the illustration.
- Make sure that the hose clamps do not interfere with the tank, tubes, hoses and other parts.

If a problem is found, repair or replace the parts as necessary.